

Haier

MRV

2022 Australia & New Zealand



Haier Intelligent Buildings

Haier Brand Story

Established in 1984, Haier Group is a world-leading provider of solutions to better life. In the process of sustainable innovation and entrepreneurship, Haier always upholds the principle of "prioritizing people's value". Mr. Zhang Ruimin, Chairman of the Board and CEO of Haier Group, first proposed the Rendanheyi Model in September 2005. After 15 years of development and innovation, Rendanheyi has achieved trans-culture, trans-industry and trans-field fusion and replication with its contemporary features, universality characteristics.

Focusing on user experience, Haier has grown from the once collectively owned small factory on the verge of bankruptcy into an ecosystem that leads the IoT era. As the world's first and only IoT ecosystem brand, Haier has been included on the list of BrandZ™ Top 100 Most Valuable Global Brands for two consecutive years. Haier has topped Global Major Appliances Brand Rankings by Euromonitor International for 11 consecutive years. It's subsidiary Haier Smart Home is among the list of Global 500 of Fortune.



To date, Haier Group owns four listed companies, has six platforms including Haier Smart Home, COSMOPlat, Ririshun, Yingkang Life, Haier Biomedical, Haina Cloud and HCH, and has Seven global brands such as Haier, Casarte, Leader, GE Appliances, Fisher & Paykel, AQUA and Candy. It has successfully incubated 5 unicorn companies and 23 gazelle companies. Moreover, Haier has established 10+N open innovation systems, 25 industrial parks, 124 manufacturing centers, 108 marketing centers and more than 140,000 sales networks around the globe, it has gone deep into 160 countries and regions globally, serving more than 1 billion users' families.

Upholding the vision of "creating new engines to growth in the era of IoT with Rendanheyi Model" , Haier Group is committed to working with its world-class ecosystem partners to continuously build premium brand, scenario brand and ecosystem brand, and to set up IoT ecosystems in clothing, food, accommodation, travel, health, elderly care, biomedicine and education, and to tailor personalized smart life for users around the globe.

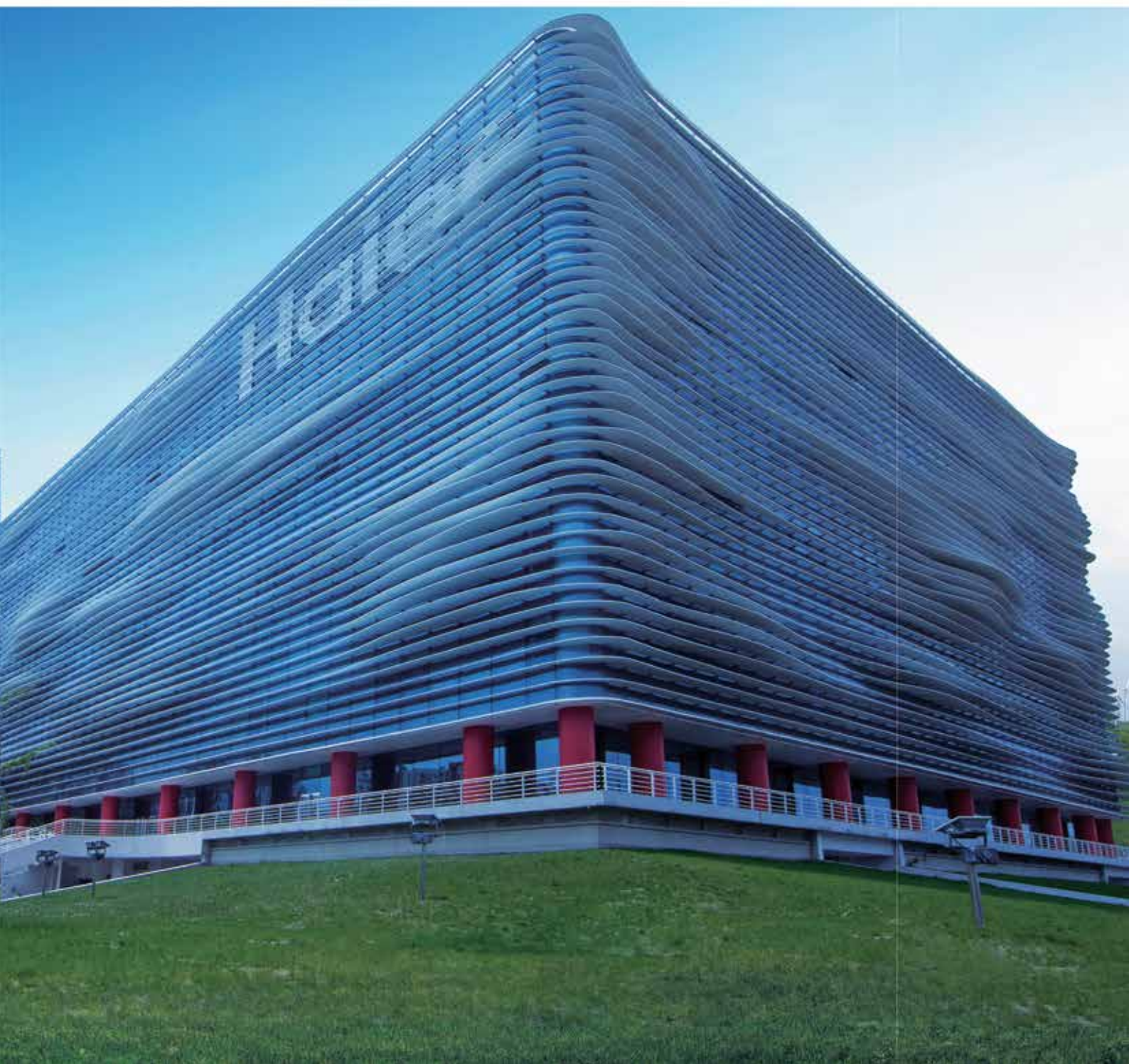

Haier Global Network

Haier has owned 10+N R&D centers, 29 industrial park, 122 factories, 108 marketing centers across the world, and the sales network over 160 countries or regions.

Haier has seven major household appliance brands across the world: Haier, Casarte, Leader, AQUA, Fisher & Paykel, GE Appliances (GEA) and CANDY. All these brands together have constituted Haier's global brand cluster, which can fully meet the best experience of different consumer groups in different regions all across the world.



Casarte Turkey Factory



Casarte Italy Factory



Haier Refrigerator Factory in Romania



GE Appliance Park, Louisville, U.S.



Haier Nigeria Factory



CAFE
GE APPLIANCES
Profile
**Haier
Hotpoint**

North America

x2 x3 x2 x10



Haier

GE APPLIANCES

Latin America

x1

10+N
R&D Centers

108
Marketing Centers

29
Industrial Parks

122
Factories

160+
Countries or Regions



Haier AC Factory in Egypt



The World's Only IoT Ecosystem Brand For 3 Years



Global No. 1 Major Appliance Brand * 13 Consecutive Years



Haier Smart Home was named one of Fortune's most admired companies in the world.



In 2020, Haier Smart Home was once again listed on the Fortune Global 500, ranking 13 up from last year.



Haier Russia Smart Ecosystem Industrial Park



Japan R&D Center



Japan IoT Laundry Factory



Haier Pakistan Economic Zone



Haier Thailand Factory



Haier Indonesia Factory



Haier India Pune Industrial Park



Haier India Greater Noida Industrial Park



FISHER & PAYKEL New Zealand R&D Center



AQUA Vietnam Factory



Haier Global Manufacturing Capacity

In China, Haier owns 8 air conditioner factories, 1 of which is MHAQ, a JV between Haier and Mitsubishi Heavy. Besides China, Haier runs another 8 overseas air conditioner factories. These factories have a total production capacity of over 27.2 million units per year.



The First Batch of Chinese Local Enterprises selected as "Lighthouse Factory" in the World

Dalian



Jiaozhou



MHAQ



Wuhan



India



Thailand



Vietnam



Haier R&D Center

Haier Air Conditioning R&D Center, located in Qingdao, China, completed in December 2013, covers 20,000 square meters. It has more than 120 laboratories, including testing laboratories, key part research laboratories and all-weather user experience simulation laboratories. The R&D center also has the world tallest "drop tower" for testing long refrigerant piping tests(106 meters tall).



Haier & Mitsubishi
Joint Laboratory



Haier & HIGHLY
Joint Laboratory

In April 2014, Haier established joint laboratories with Highly for research in heating & cooling technology and with Mitsubishi Electric for innovative technology for user experience. Research by the user experience center covers the fields of user comfort evaluation, aerodynamics, acoustics, EMC(Electro-Magnetic Compatibility) and mechanics etc. The labs can carry out more than 600 international tests as per ISO, IEC, EN, CISPR and ANSI etc. to meet the requirements of Europe, Asia, America, Australia, Middle East and other 100 countries and regions.

The user experience center gains recognition by domestic well-known certification and testing institutions, also is recognized by international organizations like TUV and Intertek etc. At Haier, we believe that the best air conditioning is one that builds on uncompromising quality control worldwide, developing and manufacturing fine products and delivering them to customers everywhere.

R&D Labs



EMC Test



Simulated Rainfall Test



Enthalpy-difference Test



Safe Test



Acoustic Labs



Centralized Control



Simulated Snow Test



Simulated Sunshine Test



Limiting Condition Test



Humidity Condition Handling



Double 85 Test



Drop Test

Global Certification



Haier MRV Milestone

Haier AC has been holding No.1 market share in Pakistan for 5 consecutive years from 2009.

Haier AC was ranked NO.5 in Italy by market share in volume in 2012 & 2013 by DATABANK.

Haier B2C website in Italy was awarded "Interactive Key Award 2013" .

Haier AC entered Winter Olympics in Sochi Russia in 2013.

1996

Home VRF (Home MRV)
First unit in China Haier first home inverter multi

2005

Modular combination MRV II
First pure DC inverter in China Technology from Toshiba

2012

MRV S Full DC inverter Side discharge outdoor
Largest capacity of side discharge

2014

MRV IV Full DC inverter, Large single module.

1993

Haier Enter into China commercial AC field

1999

Commercial VRF (C-MRV) First Modular VRF unit in China

2008

MRV III DC Inverter
23 Olympic reference projects in Beijing

2013

MRV III-RC Heat recovery (3 pipe system)

MRV W
Water-cooled / MRV



2016

MRVIII PLUS
Full DC inverter
MRV SII New platform, new outlook

2018

MRV 5-RC Launching
MRV 5-RC heat recovery range

2020

MRV 5-H
Launched
MRV 5-H

2021

MRV 5-C
launched
Cooling only series

2015

MRV IV (T3)
Full DC inverter

2017

MRV SII Launched Globly Including the first ever Haier MRV product for the north american market.

2019

US MRV 5 launched
US MRV 5 HP & HR
AHRI certification High efficiency and low operating temperature



CONTENTS

- 003** PRODUCT LINE UP
- 007** MRV 5-RC
- 025** MRV SII
- 035** MRV AHU CONNECTION KIT
- 041** MRV INDOOR UNIT
- 079** CONTROL SYSTEM
- 097** REFERENCE PROJECTS





















Haier



MRV5
DC INVERTER

PRODUCT LINE-UP



Series	HP	8	10	12	14	16	18	20	22	24	26	28	30	32	34	36	38	40	42	44	46	48
MRV 5-RC	3/380~415/50																					
	3/380~415/60																					

Series	HP	3	4	5	6	7	8	10	12
MRV S ^{II}	1/220~240/50								
	1/220~240/60								
MRV S ^{II}	3/380~415/50								
	3/380~415/60								





EASY MRV

Model	MS1-036A	MS1-060A	MS3-036A
Match with indoor	1 by 1	1 by 1	1 by 3
EASY MRV Connection Kit			
Capacity(Btu/h)	≤36K	36K<X≤60K	Every indoor capacity ≤36K
MRV series	MRV 5, MRV SII (4/5/6/8/10/12HP Double fan)		









Outdoor Units

50	52	54	56	58	60	62	64	66	68	70	72	74	76	78	80	82	84	86	88	90	92	94	96	98	100	102	104
																											

14	16	18	20	22	24	26	28	30	32	34	36

DX AHU ² Connection kit					
Model	AH1-070B	AH1-140B	AH1-280B	AH1-560B	AH1-730B
Capacity	3.5<x≤7kW	7<x≤14kW	14<x≤28kW	28<x≤56kW	56<x≤73kW
New					
MRV series	MRV 5, MRV SII (4/5/6/8/10/12HP Double fan)				

PRODUCT LINE-UP

Series	KBTU/h kW	
1-Way Cassette		AB**2MAERA
Compact Cassette		AB**2MCERA(M)
Round Way Cassette		AB**2MRERA
Slim Duct (0/15/30Pa)		AD**2MSERA(D) AD**2MSERA
High ESP Duct(20/200Pa)		AD**2MJERAD
High ESP Duct (100-250Pa)		AD**2MGERA
High Wall		AS**2MNERAB AS**2MNERA
Fresh Air Duct (Comming soon)		AD**2MJERF AD**2MTERF
HRV (Heat Reclaim Ventilation) ERV***ANW		150m ³ /h 800m ³ /h 260m ³ /h 1000m ³ /h 500m ³ /h

Indoor Units

	5	7	9	12	16	18	24	28	30	38	42	48	54	72	96
	1.5	2.2	2.8	3.6	4.5	5.6	7.1	8.0	9.0	11.2	12.5	14.0	16.0	22.6	28.0
	■	■	■	■											
	■	■	■	■	■	■									
		■	■	■	■	■	■	■	■	■		■	■		
	■	■	■	■	■	■	■								
	■	■	■	■	■	■	■	■	■	■		■	■		
														■	■
	■	■	■	■	■	■	■	■	■						
												■		■	■



MRV5-RC

DC INVERTER

009 Features & Benefits

013 MRV 5-RC Outdoor



Advanced Technology



System Introduction



High Efficiency







Easy Installation





MRV5-RC

-  Advanced Technology
-  System Introduction
-  High Efficiency
-  Easy Installation

SYSTEM INTRODUCTION

What is heat recovery VRF unit?

For the heat pump series, the units within one system can only work in the same mode. Now Haier heat recovery series, due to heat recovery pipeline design of outdoor unit and the new valve box, can achieve cooling and heating simultaneously in one system. In addition, multiple indoor unit types are provide to meet various project demands.

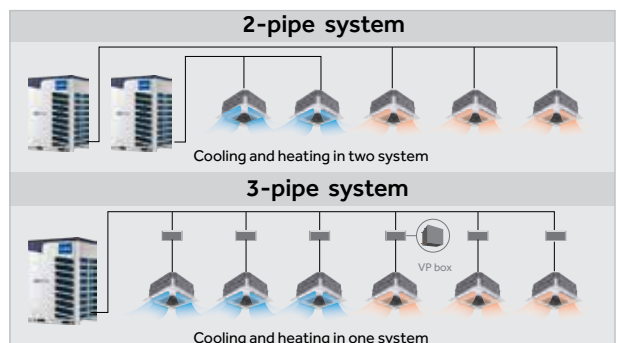

SYSTEM INTRODUCTION

Variable operation mode in one system

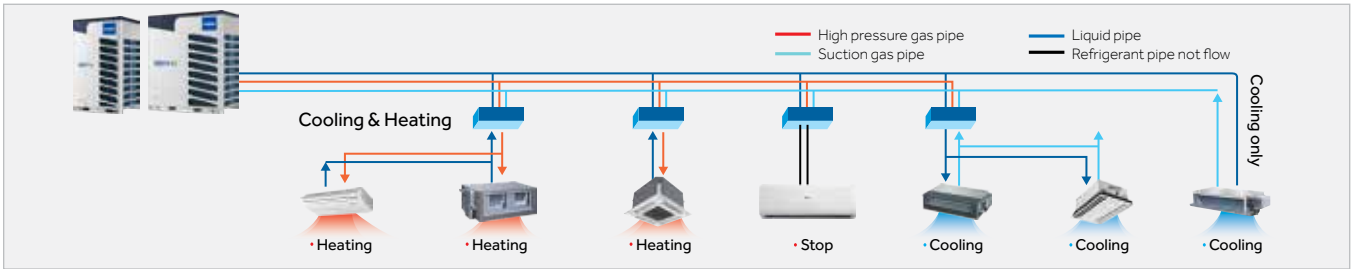

ADVANCED TECHNOLOGY

What is heat recover VRF unit?

With large capacity full DC inverter compressor, MRV 5-RC can reach single module 22HP, maximum combination 88HP.



HIGH EFFICIENCY

Two stage cooling technology

Two stage cooling of the MRV 5-RC, the subcooling degree is up to 30 °C, which greatly improves the cooling and heating capacity of the system, reduces the pressure loss of the refrigerant of the system, Improve the system capability and the long piping capability.

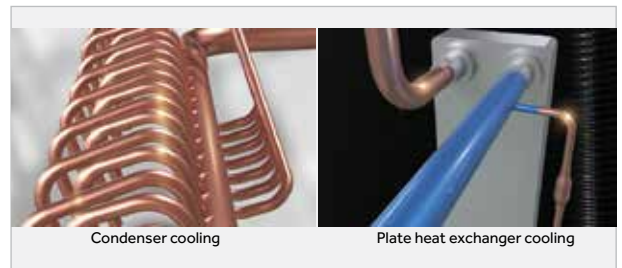

Twin pressure sensors

High pressure sensor used to real-time monitor the high pressure change. Protecting MRV 5-RC against the impact of high pressure momentary changes. Low pressure sensor used to real-time feedback compressor suction pressure, so our unit rapidly respond the change of room load.

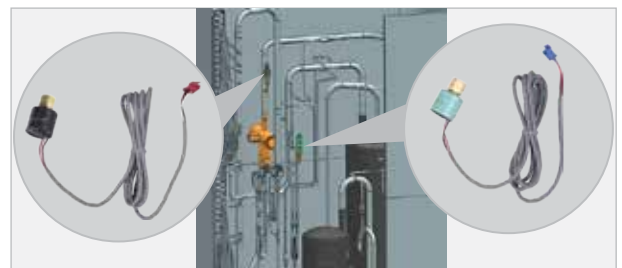

HIGH EFFICIENCY

Three layers fin and new four way heat exchanger

New three layers fin and four way heat exchanger, increase the heat exchange area, realize big capacity.



EASY INSTALLATION

VP (valve pipe) box structure overview

Overview

- Specially designed for MRV 5-RC, volume is small to 0.02m³ (for VP1 box), 0.05m³ (for VP4 box). Greatly reduced the installation space.
- Individual Valve and Pipe Box for Heat Recovery.
- The valve box can be connected in series, reduce the use of diverging pipes and reduce the installation cost.

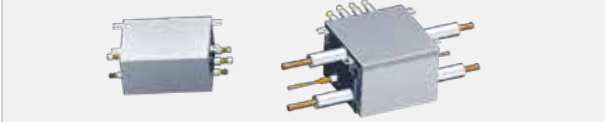

Model name	Max.capacity of indoor(kw)	Power Supply	Max. indoor units	Dimension
VP1-112C	≤11.2	1/220-240/50/60	5	388×200×277
VP1-180C	11.2<≤18	1/220-240/50/60	8	388×200×277
VP1-280C	18<≤28	1/220-240/50/60	8	388×200×277
VP4-450C	≤45	1/220-240/50/60	20	388×200×277

Door-type electric control box

Door-type design, the maintenance panel could be opened like a door, no need to remove the panel, more convenience.



Four-way pipe connection

4-way (front, back, left & right) pipe connection, according to the actual installation conditions to choice pipe connection flexible.



Auto addressing indoor units and oil balancing

Continue auto addressing indoor units and oil balancing of MRV 5-RC, improving the easy installation of system, greatly reduce the lab.





AV08IMAURA
AV10IMAURA
AV12IMAURA



AV14IMAURA
AV16IMAURA
AV18IMAURA
AV20IMAURA

3/380~415/50/60

Model			AV08IMAURA	AV10IMAURA	AV12IMAURA	
Combination model			/	/	/	
			/	/	/	
			/	/	/	
			/	/	/	
Capacity	Capacity range	HP	8	10	12	
	Cooling	kW	22.4	28	33.5	
	Heating	kW	25	31.5	35	
Electrical parameters	Power supply	Ph/V/Hz	3/380~415/50/60			
	Cooling	Rated power input	kW	5.66	7.46	9.19
		Max power input	kW	9.60	12.20	14.72
		Rated current	A	13.80	16.22	16.88
		Max current	A	23.80	27.00	26.20
	Heating	Rated power input	kW	5.77	7.96	9.25
		Max power input	kW	9.80	12.90	14.70
		Rated current	A	9.93	12.96	12.80
		Max current	A	17.20	20.30	20.08
	EER		3.56	3.40	3.32	
	AEER		3.47	3.19	3.10	
	COP	%	3.99	3.57	3.45	
ACOP	%	3.89	3.50	3.39		
Performance	Air flow (H)	m ³ /h	13500			
	Sound pressure level (H)	dB(A)	61			
Installation	External dimensions(W/D/H)	mm	980/750/1690			
	Shipping dimensions(W/D/H)	mm	1070/850/1838			
	Net/Shipping weight	kg	267/292			
	Compressor type		DC INV. SCROLL	DC INV. SCROLL	DC INV. SCROLL	
	Compressor brand		MITSUBISHI	MITSUBISHI	MITSUBISHI	
			ELECTRIC	ELECTRIC	ELECTRIC	
	Compressor quantity		1INV	1INV	1INV	
	Refrigerant type		R410A	R410A	R410A	
	Refrigerant charge	kg	11.5	12.5	14	
	Refrigerant liquid pipe	mm	9.52	9.52	12.7	
	Refrigerant gas pipe	mm	19.05	22.22	25.4	
	Refrigerant high gas pipe	mm	19.05	19.05	22.22	
	Max.total pipe lenth	m	1000	1000	1000	
	Max. pipe length (Equivalent/Actual)	m	260/220	260/220	260/220	
	Max drop between I.U.&O.U. (O.U. down/up) *1	m	110/90	110/90	110/90	
	Standard drop between I.U.&O.U. (O.U. up/down) *2	m	50/40	50/40	50/40	
	Max drop between I.U. *3	m	30	30	30	
Standard drop between I.U. *4	m	18	18	18		
External static pressure	Pa	110	110	110		
Connection ratio	Connectable indoor unit ratio	%	50~130	50~130	50~130	
	Maximum number of indoor units		15	17	20	
Working temp.	Cooling	°C	-5~48			
	Heating	°C	-15~21			

Max drop between I.U.&O.U. *1
Standard design and production in the factory.
Max drop between I.U. *3
Standard design and production in the factory.
Standard drop between I.U. *4
Standard design and production in the factory.
* All the specifications are tested under nominal condition(in cooling, indoor temp. is 27°C DB/19°C WB, Outdoor temp 35°C DB/24°C WB; in heating, indoor temp. is 20°C DB, in heating, outdoor temp. is 7°C DB/6°CWB)

MRV5-RC

DC INVERTER



3/380~415/50/60



AV08IMVURA
AV10IMVURA
AV12IMVURA
AV14IMVURA



AV16IMVURA
AV18IMVURA
AV20IMVURA
AV22IMVURA

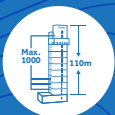

Total pipe length 1000m,
height drop 110m



Full DC inverter
compressors



Single module 22HP,
maximum combination 88HP



Automatic
Oil balancing

Model			AV14IMAURA	AV16IMAURA	
Combination model			/	/	
			/	/	
			/	/	
			/	/	
Capacity	Capacity range	HP	14	16	
	Cooling	kW	40	45	
	Heating	kW	45	50	
Electrical parameters	Power supply	Ph/V/Hz	3/380~415/50/60	3/380~415/50/60	
	Cooling	Rated power input	kW	11.22	12.75
		Max power input	kW	20.16	22.66
		Rated current	A	24.78	25.42
		Max current	A	43.25	41.73
	Heating	Rated power input	kW	11.76	13.27
		Max power input	kW	21.01	23.43
		Rated current	A	20.07	21.73
		Max current	A	33.23	35.54
	EER			3.32	3.25
	AEER			3.28	3.21
	COP		%	3.59	3.53
	ACOP		%	3.55	3.50
Performance	Air flow (H)	m ³ /h	19000	19000	
	Sound pressure level (H)	dB(A)	64	64	
Installation	External dimensions(W/D/H)	mm	1410/750/1690		
	Shipping dimensions(W/D/H)	mm	1515/850/1838		
	Net/Shipping weight	kg	385/414		
	Compressor type		DC INV. SCROLL	DC INV. SCROLL	
	Compressor brand		MITSUBISHI ELECTRIC	MITSUBISHI ELECTRIC	
	Compressor quantity		2INV	2INV	
	Refrigerant type		R410A	R410A	
	Refrigerant charge	kg	17.5	17.5	
	Refrigerant liquid pipe	mm	12.7	12.7	
	Refrigerant gas pipe	mm	25.4	28.58	
	Refrigerant high gas pipe	mm	22.22	25.4	
	Max.total pipe lenth	m	1000	1000	
	Max.pipe length (Equivalent/Actual)	m	260/220	260/220	
	Max drop between I.U.&O.U. (O.U. down/up) *1	m	110/90	110/90	
	Standard drop between I.U.&O.U. (O.U. up/down) *2	m	50/40	50/40	
	Max drop between I.U. *3	m	30	30	
	Standard drop between I.U. *4	m	18	18	
External static pressure	Pa	110	110		
Connection ratio	Connectable indoor unit ratio	%	50~130	50~130	
	Maximum number of indoor units		24	27	
Working temp.	Cooling	°C	-5~48		
	Heating	°C	-15~21		



AV18IMAURA	AV20IMAURA	AV22IMAURA	AV24IMAURA	AV26IMAURA
/	/	AV10IMAURA	AV12IMAURA	AV12IMAURA
/	/	AV12IMAURA	AV12IMAURA	AV14IMAURA
/	/	/	/	/
/	/	/	/	/
18	20	22	24	26
50	56	61.5	67	73.5
56.5	58	66.5	70	80
3/380-415/50/60	3/380-415/50/60	3/380-415/50/60	3/380-415/50/60	3/380-415/50/60
14.06	16.73	16.65	18.38	20.41
24.70	28.50	27.80	30.69	34.08
30.32	35.14	33.10	33.76	41.66
47.94	55.09	55.27	56.37	69.56
15.93	15.08	17.21	18.5	21.01
27.30	26.10	28.73	30.89	35.08
23.93	26.13	25.76	25.6	32.87
38.65	41.87	43.01	42.74	54.88
3.23	3.10	3.69	3.65	3.60
3.20	2.90	3.14	3.10	3.20
3.30	3.42	3.86	3.78	3.81
3.27	3.39	3.44	3.39	3.48
19000	19000	27000.00	27000	32500
64	64	64	64	66
1410/750/1690		980/750/1690*2	980/750/1690*2	980/750/1690+1410/750/1690
1515/850/1838		1070/850/1838*2	1070/850/1838*2	1070/850/1838+1515/850/1838
385/414		267/292*2	267/292*2	267/292+385/414
DC INV. SCROLL	DC INV. SCROLL	DC INV. SCROLL	DC INV. SCROLL	DC INV. SCROLL
mitsubishi	mitsubishi	mitsubishi	mitsubishi	mitsubishi
ELECTRIC	ELECTRIC	ELECTRIC	ELECTRIC	ELECTRIC
2INV	2INV	1INV+1INV	1INV+1INV	1INV+2INV
R410A	R410A	R410A	R410A	R410A
17.5	18.5	12.5+14	14+14	14+17.5
15.88	15.88	15.88	15.88	15.88
28.58	28.58	28.58	28.58	28.58
25.4	25.4	25.4	25.4	25.4
1000	1000	1000	1000	1000
260/220	260/220	260/220	260/220	260/220
110/90	110/90	110/90	110/90	110/90
50/40	50/40	50/40	50/40	50/40
30	30	30	30	30
18	18	18	18	18
110	110	110	110	110
50-130	50-130	50-130	50-130	50-130
30	33	36	40	43
		-5-48		
		-15-21		

Max drop between I.U.&O.U *1
 Standard drop between I.U.&O.U *2
 Max drop between I.U. *3
 Standard drop between I.U. *4
 * All the specifications are tested under nominal condition (in cooling, indoor temp. is 27°C DB/19°C WB, Outdoor temp 35°C DB/24°C WB, in heating, indoor temp. is 20°C DB, in heating, outdoor temp. is 7°C DB/6°CWB)

If the height difference between the outdoor and the indoor units is from 50 to 110m, you MUST contact your local distributor/dealer for individual design and production.
 Standard design and production in the factory.
 If the height difference between the indoor units is from 18 to 30m, you MUST contact your local distributor/dealer for individual design and production.
 Standard design and production in the factory.

MRV5-RC

DC INVERTER



3/380~415/50/60



AV08IMVURA
AV10IMVURA
AV12IMVURA
AV14IMVURA



AV16IMVURA
AV18IMVURA
AV20IMVURA
AV22IMVURA

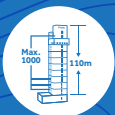

Total pipe length 1000m,
height drop 110m



Full DC inverter
compressors



Single module 22HP,
maximum combination 88HP



Automatic
Oil balancing

Model			AV281MAURA	AV301MAURA	
	Combination model		AV141MAURA	AV141MAURA	
			AV141MAURA	AV161MAURA	
			/	/	
			/	/	
Capacity	Capacity range	HP	28	30	
	Cooling	kW	80	85	
	Heating	kW	90	95	
Electrical parameters	Power supply	Ph/V/Hz	3/380-415/50/60	3/380-415/50/60	
	Cooling	Rated power input	kW	22.44	23.97
		Max power input	kW	37.47	40.02
		Rated current	A	49.56	50.2
		Max current	A	82.75	83.82
	Heating	Rated power input	kW	23.52	25.03
		Max power input	kW	39.27	41.79
		Rated current	A	40.14	41.8
		Max current	A	67.02	69.79
		EER		3.57	3.55
		AEER		3.28	3.24
		COP	%	3.83	3.80
		ACOP	%	3.55	3.52
Performance	Air flow (H)	m ³ /h	38000	38000	
	Sound pressure level (H)	dB(A)	67	67	
Installation	External dimensions(W/D/H)	mm	1410/750/1690*2	1410/750/1690*2	
	Shipping dimensions(W/D/H)	mm	1515/850/1838*2	1515/850/1838*2	
	Net/Shipping weight	kg	385/414*2	385/414*2	
	Compressor type		DC INV. SCROLL	DC INV. SCROLL	
	Compressor brand		mitsubishi electric	mitsubishi electric	
	Compressor quantity		2INV*2	2INV*2	
	Refrigerant type		R410A	R410A	
	Refrigerant charge	kg	17.5+17.5	17.5+17.5	
	Refrigerant liquid pipe	mm	15.88	19.05	
	Refrigerant gas pipe	mm	28.58	31.8	
	Refrigerant high gas pipe	mm	25.4	28.58	
	Max.total pipe lenth	m	1000	1000	
	Max.pipe length (Equivalent/Actual)	m	260/220	260/220	
	Max drop between I.U.&O.U. (O.U. down/up) *1	m	110/90	110/90	
	Standard drop between I.U.&O.U. (O.U. up/down) *2	m	50/40	50/40	
	Max drop between I.U. *3	m	30	30	
Standard drop between I.U. *4	m	18	18		
External static pressure	Pa	110	110		
Connection ratio	Connectable indoor unit ratio	%	50~130	50~130	
	Maximum number of indoor units		46	50	
Working temp.	Cooling	°C	-5~48		
	Heating	°C	-15~21		



AV32IMAURA	AV34IMAURA	AV36IMAURA	AV38IMAURA	AV40IMAURA
AV16IMAURA	AV16IMAURA	AV18IMAURA	AV18IMAURA	AV20IMAURA
AV16IMAURA	AV18IMAURA	AV18IMAURA	AV20IMAURA	AV20IMAURA
/	/	/	/	/
/	/	/	/	/
32	34	36	38	40
90	95	100	106	112
100	106.5	113	114.5	116
3/380-415/50/60	3/380-415/50/60	3/380-415/50/60	3/380-415/50/60	3/380-415/50/60
25.5	26.81	28.12	30.79	33.46
42.58	44.76	46.95	51.41	55.87
50.84	55.74	60.64	65.46	70.28
84.89	93.07	101.25	109.30	117.34
26.54	29.2	31.86	31.01	30.16
44.31	48.75	53.20	51.78	50.36
43.46	45.66	47.86	50.06	52.26
72.56	76.24	79.91	83.58	87.26
3.53	3.54	3.56	3.44	3.35
3.21	3.20	3.20	3.03	2.90
3.77	3.65	3.55	3.69	3.85
3.50	3.37	3.27	3.33	3.39
38000	38000	38000	38000	38000
67	67	67	67	67
1410/750/1690*2	1410/750/1690*2	1410/750/1690*2	1410/750/1690*2	1410/750/1690*2
1515/850/1838*2	1515/850/1838*2	1515/850/1838*2	1515/850/1838*2	1515/850/1838*2
385/414*2	385/414*2	385/414*2	385/414*2	385/414*2
DC INV. SCROLL	DC INV. SCROLL	DC INV. SCROLL	DC INV. SCROLL	DC INV. SCROLL
mitsubishi	mitsubishi	mitsubishi	mitsubishi	mitsubishi
ELECTRIC	ELECTRIC	ELECTRIC	ELECTRIC	ELECTRIC
2INV*2	2INV*2	2INV*2	2INV*2	2INV*2
R410A	R410A	R410A	R410A	R410A
17.5+17.5	17.5+17.5	17.5+17.5	17.5+18.5	18.5+18.5
19.05	19.05	19.05	19.05	19.05
31.8	31.8	38.1	38.1	38.1
28.58	28.58	34.9	34.9	34.9
1000	1000	1000	1000	1000
260/220	260/220	260/220	260/220	260/220
110/90	110/90	110/90	110/90	110/90
50/40	50/40	50/40	50/40	50/40
30	30	30	30	30
18	18	18	18	18
110	110	110	110	110
50-130	50-130	50-130	50-130	50-130
53	57	60	64	64
		-5-48		
		-15-21		

Max drop between I.U.&O.U. *1
Standard design and production in the factory.
Max drop between I.U. *3
Standard design and production in the factory.
Standard drop between I.U. *4
* All the specifications are tested under nominal condition (in cooling, indoor temp. is 27°C DB/19°C WB, Outdoor temp. 35°C DB/24°C WB, in heating, indoor temp. is 20°C DB, in heating, outdoor temp. is 7°C DB/6°CWB)

MRV5-RC

DC INVERTER

3/380~415/50/60



AV08IMVURA
AV10IMVURA
AV12IMVURA
AV14IMVURA



AV16IMVURA
AV18IMVURA
AV20IMVURA
AV22IMVURA

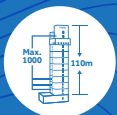

Total pipe length 1000m,
height drop 110m



Full DC inverter
compressors



Single module 22HP,
maximum combination 88HP



Automatic
Oil balancing



Model		AV421MAURA		
Combination model		AV141MAURA		
		AV141MAURA		
		AV141MAURA		
		/		
Capacity	Capacity range	HP	42	
	Cooling	kW	120	
	Heating	kW	135	
Electrical parameters	Power supply	Ph/V/Hz	3/380~415/50/60	
	Cooling	Rated power input	kW	33.66
		Max power input	kW	56.20
		Rated current	A	74.34
		Max current	A	124.12
	Heating	Rated power input	kW	35.28
		Max power input	kW	58.91
		Rated current	A	60.21
		Max current	A	100.53
	EER			3.57
	AEER			3.28
	COP		%	3.83
ACOP		%	3.55	
Performance	Air flow (H)	m ³ /h	57000	
	Sound pressure level (H)	dB(A)	69	
Installation	External dimensions(W/D/H)	mm	1410/750/1690*3	
	Shipping dimensions(W/D/H)	mm	1515/850/1838*3	
	Net/Shipping weight	kg	385/414*3	
	Compressor type		DC INV. SCROLL	
	Compressor brand		mitsubishi electric	
	Compressor quantity		2INV*3	
	Refrigerant type		R410A	
	Refrigerant charge	kg	17.5+17.5+17.5	
	Refrigerant liquid pipe	mm	19.05	
	Refrigerant gas pipe	mm	38.1	
	Refrigerant high gas pipe	mm	34.9	
	Max.total pipe lenth	m	1000	
	Max. pipe length (Equivalent/Actual)	m	260/220	
	Max drop between I.U.&O.U. (O.U. down/up) *1	m	110/90	
	Standard drop between I.U.&O.U. (O.U. up/down) *2	m	50/40	
	Max drop between I.U. *3	m	30	
	Standard drop between I.U. *4	m	18	
External static pressure	Pa	110		
Connection ratio	Connectable indoor unit ratio	%	50~130	
	Maximum number of indoor units		64	
Working temp.	Cooling	°C	-5~48	
	Heating	°C	-15~21	



AV44IMAURA	AV46IMAURA	AV48IMAURA	AV50IMAURA	AV52IMAURA
AV14IMAURA	AV14IMAURA	AV16IMAURA	AV16IMAURA	AV16IMAURA
AV14IMAURA	AV16IMAURA	AV16IMAURA	AV16IMAURA	AV18IMAURA
AV16IMAURA	AV16IMAURA	AV16IMAURA	AV18IMAURA	AV18IMAURA
/	/	/	/	/
44	46	48	50	52
125	130	135	140	145
140	145	150	156.5	163
3/380-415/50/60	3/380-415/50/60	3/380-415/50/60	3/380-415/50/60	3/380-415/50/60
35.19	36.72	38.25	39.56	40.87
58.76	61.31	63.86	66.05	68.24
74.98	75.62	76.26	81.16	86.06
125.19	126.26	127.33	135.51	143.69
36.79	38.3	39.81	42.47	45.13
61.43	63.95	66.47	70.91	75.35
61.87	63.53	65.19	67.39	69.59
103.30	106.07	108.84	112.52	116.19
3.55	3.54	3.53	3.54	3.55
3.25	3.23	3.21	3.21	3.20
3.81	3.79	3.77	3.68	3.61
3.53	3.52	3.50	3.41	3.34
57000	57000	57000	57000	57000
69	69	69	69	69
1410/750/1690*3	1410/750/1690*3	1410/750/1690*3	1410/750/1690*3	1410/750/1690*3
1515/850/1838*3	1515/850/1838*3	1515/850/1838*3	1515/850/1838*3	1515/850/1838*3
385/414*3	385/414*3	385/414*3	385/414*3	385/414*3
DC INV. SCROLL	DC INV. SCROLL	DC INV. SCROLL	DC INV. SCROLL	DC INV. SCROLL
mitsubishi	mitsubishi	mitsubishi	mitsubishi	mitsubishi
ELECTRIC	ELECTRIC	ELECTRIC	ELECTRIC	ELECTRIC
2INV*3	2INV*3	2INV*3	2INV*3	2INV*3
R410A	R410A	R410A	R410A	R410A
17.5+17.5+17.5	17.5+17.5+17.5	17.5+17.5+17.5	17.5+17.5+17.5	17.5+17.5+17.5
19.05	19.05	19.05	19.05	19.05
38.1	38.1	38.1	38.1	38.1
34.9	34.9	34.9	34.9	34.9
1000	1000	1000	1000	1000
260/220	260/220	260/220	260/220	260/220
110/90	110/90	110/90	110/90	110/90
50/40	50/40	50/40	50/40	50/40
30	30	30	30	30
18	18	18	18	18
110	110	110	110	110
50~130	50~130	50~130	50~130	50~130
64	64	64	64	64
		-5~48		
		-15~21		

Max drop between I.U.&O.U. *1
 Standard drop between I.U.&O.U. *2
 Max drop between I.U. *3
 Standard drop between I.U. *4
 * All the specifications are tested under nominal condition (in cooling, indoor temp. is 27°C DB/19°C WB, Outdoor temp. 35°C DB/24°C WB; in heating, indoor temp. is 20°C DB in heating, outdoor temp. is 7°C DB/6°C WB)

If the height difference between the outdoor and the indoor units is from 50 to 110m, you MUST contact your local distributor/dealer for individual design and production.
 Standard design and production in the factory.
 If the height difference between the indoor units is from 18 to 30m, you MUST contact your local distributor/dealer for individual design and production.
 Standard design and production in the factory.

MRV5-RC

DC INVERTER

3/380~415/50/60



AV08IMVURA
AV10IMVURA
AV12IMVURA
AV14IMVURA



AV16IMVURA
AV18IMVURA
AV20IMVURA
AV22IMVURA

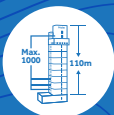

Total pipe length 1000m,
height drop 110m



Full DC inverter
compressors



Single module 22HP,
maximum combination 88HP



Automatic
Oil balancing



Model		AV54IMAURA		
Combination model			AV18IMAURA	
			AV18IMAURA	
			AV18IMAURA	
			/	
Capacity	Capacity range	HP	54	
	Cooling	kW	150	
	Heating	kW	169.5	
Electrical parameters	Power supply	Ph/V/Hz	3/380~415/50/60	
	Cooling	Rated power input	kW	42.18
		Max power input	kW	70.43
		Rated current	A	90.96
		Max current	A	151.87
	Heating	Rated power input	kW	47.79
		Max power input	kW	79.79
		Rated current	A	71.79
		Max current	A	119.86
	EER			3.56
AEER			3.20	
COP		%	3.55	
ACOP		%	3.27	
Performance	Air flow (H)	m ³ /h	57000	
	Sound pressure level (H)	dB(A)	69	
Installation	External dimensions(W/D/H)	mm	1410/750/1690*3	
	Shipping dimensions(W/D/H)	mm	1515/850/1838*3	
	Net/Shipping weight	kg	385/414*3	
	Compressor type		DC INV. SCROLL	
	Compressor brand		mitsubishi electric	
	Compressor quantity		2INV*3	
	Refrigerant type		R410A	
	Refrigerant charge	kg	17.5+17.5+17.5	
	Refrigerant liquid pipe	mm	19.05	
	Refrigerant gas pipe	mm	38.1	
	Refrigerant high gas pipe	mm	34.9	
	Max.total pipe lenth	m	1000	
	Max. pipe length (Equivalent/Actual)	m	260/220	
	Max drop between I.U.&O.U. (O.U. down/up) *1	m	110/90	
	Standard drop between I.U.&O.U. (O.U. up/down) *2	m	50/40	
	Max drop between I.U. *3	m	30	
Standard drop between I.U. *4	m	18		
External static pressure	Pa	110		
Connection ratio	Connectable indoor unit ratio	%	50~130	
	Maximum number of indoor units		64	
Working temp.	Cooling	°C	-5~48	
	Heating	°C	-15~21	



AV561MAURA	AV581MAURA	AV601MAURA	AV621MAURA	AV641MAURA
AV181MAURA	AV181MAURA	AV201MAURA	AV141MAURA	AV161MAURA
AV181MAURA	AV201MAURA	AV201MAURA	AV161MAURA	AV161MAURA
AV201MAURA	AV201MAURA	AV201MAURA	AV161MAURA	AV161MAURA
/	/	/	AV161MAURA	AV161MAURA
56	58	60	62	64
156	162	168	175	180
171	172.5	174	195	200
3/380-415/50/60	3/380-415/50/60	3/380-415/50/60	3/380-415/50/60	3/380-415/50/60
44.85	47.52	50.19	49.47	51
74.88	79.34	83.80	82.60	85.15
95.78	100.6	105.42	101.04	101.68
159.92	167.97	176.02	168.70	169.77
46.94	46.09	45.24	51.57	53.08
78.37	76.95	75.54	86.10	88.63
73.99	76.19	78.39	85.26	86.92
123.54	127.21	130.88	142.35	145.13
3.48	3.41	3.35	3.54	3.53
3.09	2.99	2.90	3.23	3.21
3.64	3.74	3.85	3.78	3.77
3.31	3.35	3.39	3.51	3.50
57000	57000	57000	76000	76000
69	69	69	70	70
1410/750/1690*3	1410/750/1690*3	1410/750/1690*3	1410/750/1690*4	1410/750/1690*4
1515/850/1838*3	1515/850/1838*3	1515/850/1838*3	1515/850/1838*4	1515/850/1838*4
385/414*3	385/414*3	385/414*3	385/414*4	385/414*4
DC INV. SCROLL	DC INV. SCROLL	DC INV. SCROLL	DC INV. SCROLL	DC INV. SCROLL
mitsubishi	mitsubishi	mitsubishi	mitsubishi	mitsubishi
ELECTRIC	ELECTRIC	ELECTRIC	ELECTRIC	ELECTRIC
2INV*3	2INV*3	2INV*3	2INV*4	2INV*4
R410A	R410A	R410A	R410A	R410A
17.5+17.5+18.5	17.5+18.5+18.5	18.5+18.5+18.5	17.5+17.5+17.5+17.5	17.5+17.5+17.5+17.5
19.05	19.05	19.05	19.05	19.05
38.1	41.3	41.3	41.3	41.3
34.9	34.9	34.9	34.9	34.9
1000	1000	1000	1000	1000
260/220	260/220	260/220	260/220	260/220
110/90	110/90	110/90	110/90	110/90
50/40	50/40	50/40	50/40	50/40
30	30	30	30	30
18	18	18	18	18
110	110	110	110	110
50~130	50~130	50~130	50~130	50~130
64	64	64	64	64
		-5~48		
		-15~21		

Max drop between I.U.&O.U *1
Standard drop between I.U.&O.U *2
Max drop between I.U. *3
Standard drop between I.U. *4
* All the specifications are tested under nominal condition (in cooling, indoor temp. is 27°C DB/19°C WB, Outdoor temp 35°C DB/24WB, in heating, indoor temp is 20°C DB, in heating, outdoor temp is 7°C DB/6°CWB)

If the height difference between the outdoor and the indoor units is from 50 to 110m, you MUST contact your local distributor/dealer for individual design and production.
Standard design and production in the factory.

If the height difference between the indoor units is from 18 to 30m, you MUST contact your local distributor/dealer for individual design and production.
Standard design and production in the factory.

MRV5-RC

DC INVERTER

3/380~415/50/60



AV08IMVURA
AV10IMVURA
AV12IMVURA
AV14IMVURA



AV16IMVURA
AV18IMVURA
AV20IMVURA
AV22IMVURA

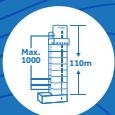

Total pipe length 1000m,
height drop 110m



Full DC inverter
compressors



Single module 22HP,
maximum combination 88HP



Automatic
Oil balancing



Model		AV661MAURA		
	Combination model	AV161MAURA		
		AV161MAURA		
		AV161MAURA		
		AV181MAURA		
Capacity	Capacity range	HP	66	
	Cooling	kW	185	
	Heating	kW	206.5	
Electrical parameters	Power supply	Ph/V/Hz	3/380~415/50/60	
	Cooling	Rated power input	kW	52.31
		Max power input	kW	87.34
		Rated current	A	106.58
		Max current	A	177.95
	Heating	Rated power input	kW	55.74
		Max power input	kW	93.07
		Rated current	A	89.12
		Max current	A	148.80
	EER			3.54
AEER			3.21	
COP		%	3.70	
ACOP		%	3.43	
Performance	Air flow (H)	m ³ /h	76000	
	Sound pressure level (H)	dB(A)	70	
Installation	External dimensions(W/D/H)	mm	1410/750/1690*4	
	Shipping dimensions(W/D/H)	mm	1515/850/1838*4	
	Net/Shipping weight	kg	385/414*4	
	Compressor type		DC INV. SCROLL	
	Compressor brand		mitsubishi electric	
	Compressor quantity		2INV*4	
	Refrigerant type		R410A	
	Refrigerant charge	kg	17.5+17.5+17.5+17.5	
	Refrigerant liquid pipe	mm	19.05	
	Refrigerant gas pipe	mm	41.3	
	Refrigerant high gas pipe	mm	34.9	
	Max.total pipe length	m	1000	
	Max.pipe length (Equivalent/Actual)	m	260/220	
	Max drop between I.U.&O.U. (O.U. down/up) *1	m	110/90	
	Standard drop between I.U.&O.U. (O.U. up/down) *2	m	50/40	
Max drop between I.U. *3	m	30		
Standard drop between I.U. *4	m	18		
External static pressure	Pa	110		
Connection ratio	Connectable indoor unit ratio	%	50~130	
	Maximum number of indoor units		64	
Working temp.	Cooling	°C	-5~48	
	Heating	°C	-15~21	



AV68IMAURA	AV70IMAURA	AV72IMAURA
AV16IMAURA	AV16IMAURA	AV18IMAURA
AV16IMAURA	AV18IMAURA	AV18IMAURA
AV18IMAURA	AV18IMAURA	AV18IMAURA
AV18IMAURA	AV18IMAURA	AV18IMAURA
68	70	72
190	195	200
213	219.5	226
3/380-415/50/60	3/380-415/50/60	3/380-415/50/60
53.62	54.93	56.24
89.53	91.71	93.90
111.48	116.38	121.28
186.13	194.31	202.50
58.4	61.06	63.72
97.51	101.95	106.39
91.32	93.52	95.72
152.47	156.15	159.82
3.54	3.55	3.56
3.20	3.20	3.20
3.65	3.59	3.55
3.37	3.32	3.27
76000	76000	76000
70	70	70
1410/750/1690*4	1410/750/1690*4	1410/750/1690*4
1515/850/1838*4	1515/850/1838*4	1515/850/1838*4
385/414*4	385/414*4	385/414*4
DC INV. SCROLL	DC INV. SCROLL	DC INV. SCROLL
mitsubishi	mitsubishi	mitsubishi
ELECTRIC	ELECTRIC	ELECTRIC
2INV*4	2INV*4	2INV*4
R410A	R410A	R410A
17.5+17.5+17.5+17.5	17.5+17.5+17.5+17.5	17.5+17.5+17.5+17.5
22.22	22.22	22.22
44.5	44.5	44.5
34.9	34.9	34.9
1000	1000	1000
260/220	260/220	260/220
110/90	110/90	110/90
50/40	50/40	50/40
30	30	30
18	18	18
110	110	110
50-130	50-130	50-130
64	64	64
	-5-48	
	-15-21	

Max drop between I.U.&O.U. *1
 Standard drop between I.U.&O.U. *2
 Max drop between I.U. *3
 Standard drop between I.U. *4
 * All the specifications are tested under nominal condition (in cooling, indoor temp. is 27°C DB/19°C WB, Outdoor temp 35°C DB/24°C WB; in heating, indoor temp. is 20°C DB, in heating, outdoor temp. is 7°C DB/6°C WB)

If the height difference between the outdoor and the indoor units is from 50 to 110m, you MUST contact your local distributor/dealer for individual design and production.
 Standard design and production in the factory.
 If the height difference between the indoor units is from 18 to 30m, you MUST contact your local distributor/dealer for individual design and production.
 Standard design and production in the factory.

MRV5-RC

DC INVERTER

3/380~415/50/60



AV08IMVURA
AV10IMVURA
AV12IMVURA
AV14IMVURA



AV16IMVURA
AV18IMVURA
AV20IMVURA
AV22IMVURA

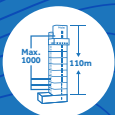

Total pipe length 1000m,
height drop 110m



Full DC inverter
compressors



Single module 22HP,
maximum combination 88HP



Automatic
Oil balancing



Model		AV741MAURA		
	Combination model	AV181MAURA		
		AV181MAURA		
		AV181MAURA		
		AV201MAURA		
Capacity	Capacity range	HP	74	
	Cooling	kW	206	
	Heating	kW	227.5	
Electrical parameters	Power supply	Ph/V/Hz	3/380~415/50/60	
	Cooling	Rated power input	kW	58.91
		Max power input	kW	98.36
		Rated current	A	126.1
		Max current	A	210.54
	Heating	Rated power input	kW	62.87
		Max power input	kW	104.97
		Rated current	A	97.92
		Max current	A	163.49
	EER			3.50
AEER			3.11	
COP		%	3.62	
ACOP		%	3.30	
Performance	Air flow (H)	m ³ /h	76000	
	Sound pressure level (H)	dB(A)	70	
Installation	External dimensions(W/D/H)	mm	1410/750/1690*4	
	Shipping dimensions(W/D/H)	mm	1515/850/1838*4	
	Net/Shipping weight	kg	385/414*4	
	Compressor type		DC INV. SCROLL	
	Compressor brand		mitsubishi electric	
	Compressor quantity		2INV*4	
	Refrigerant type		R410A	
	Refrigerant charge	kg	17.5+17.5+17.5+18.5	
	Refrigerant liquid pipe	mm	22.22	
	Refrigerant gas pipe	mm	44.5	
	Refrigerant high gas pipe	mm	34.9	
	Max.total pipe lenth	m	1000	
	Max.pipe length (Equivalent/Actual)	m	260/220	
	Max drop between I.U.&O.U. (O.U. down/up) *1	m	110/90	
	Standard drop between I.U.&O.U. (O.U. up/down) *2	m	50/40	
	Max drop between I.U. *3	m	30	
Standard drop between I.U. *4	m	18		
External static pressure	Pa	110		
Connection ratio	Connectable indoor unit ratio	%	50~130	
	Maximum number of indoor units		64	
Working temp.	Cooling	°C	-5~48	
	Heating	°C	-15~21	



AV76IMAURA	AV78IMAURA	AV80IMAURA
AV18IMAURA	AV18IMAURA	AV20IMAURA
AV18IMAURA	AV20IMAURA	AV20IMAURA
AV20IMAURA	AV20IMAURA	AV20IMAURA
AV20IMAURA	AV20IMAURA	AV20IMAURA
76	78	80
212	218	224
229	230.5	232
3/380-415/50/60	3/380-415/50/60	3/380-415/50/60
61.58	64.25	66.92
102.82	107.28	111.73
130.92	135.74	140.56
218.59	226.64	234.69
62.02	61.17	60.32
103.55	102.13	100.71
100.12	102.32	104.52
167.17	170.84	174.51
3.44	3.39	3.35
3.03	2.96	2.90
3.69	3.77	3.85
3.33	3.36	3.39
76000	76000	76000
70	70	70
1410/750/1690*4	1410/750/1690*4	1410/750/1690*4
1515/850/1838*4	1515/850/1838*4	1515/850/1838*4
385/414*4	385/414*4	385/414*4
DC INV. SCROLL	DC INV. SCROLL	DC INV. SCROLL
mitsubishi	mitsubishi	mitsubishi
ELECTRIC	ELECTRIC	ELECTRIC
2INV*4	2INV*4	2INV*4
R410A	R410A	R410A
17.5+17.5+18.5+18.5	17.5+18.5+18.5+18.5	18.5+18.5+18.5+18.5
22.22	22.22	22.22
44.5	44.5	44.5
34.9	38.1	38.1
1000	1000	1000
260/220	260/220	260/220
110/90	110/90	110/90
50/40	50/40	50/40
30	30	30
18	18	18
110	110	110
50-130	50-130	50-130
64	64	64
	-5-48	
	-15-21	

Max drop between I.U.&O.U. *1
 Standard drop between I.U.&O.U. *2
 Max drop between I.U. *3
 Standard drop between I.U. *4
 * All the specifications are tested under nominal condition (in cooling, indoor temp. is 27°C DB/19°C WB, Outdoor temp 35°C DB/24°C WB, in heating, indoor temp. is 20°C DB, in heating, outdoor temp. is 7°C DB/6°C WB)

If the height difference between the outdoor and the indoor units is from 50 to 110m, you MUST contact your local distributor/dealer for individual design and production.
 Standard design and production in the factory.
 If the height difference between the indoor units is from 18 to 30m, you MUST contact your local distributor/dealer for individual design and production.
 Standard design and production in the factory.

MRV S^{II}

027 Features & Benefits

032 MRV S^{II} Outdoor

034 Dimensions



Advanced Technology



High Efficiency



Super Comfort



Easy Installation



High Reliability



Haier

MRV S^{II}

027 Features & Benefits

032 MRV S^{II} Outdoor

034 Dimensions



Advanced Technology



High Efficiency



Super Comfort



Easy Installation



High Reliability



Haier



MRV S II



Advanced Technology



High Efficiency



Super Comfort



Easy Installation



High Reliability



ADVANCED TECHNOLOGY

Leadership in technology(4-6HP)

- Two-stage supercooling cycle technology, increased unit efficiency by 9%. (Double fan)
- Maximizing 30°C undercooling, increase unit refrigerating capacity by 46%.



Increasing enthalpy by replenish gas, realize the unit powerful heating capacity

Taking the heating cycle as an example, when environment temperature is low, heat exchanged capability of outdoor unit is depressed. The amount of gas returned by compressor is reduced, Increase the amount of refrigerant in the heating cycle of the indoor unit heat exchanger, Thereby achieving improved heating capacity.

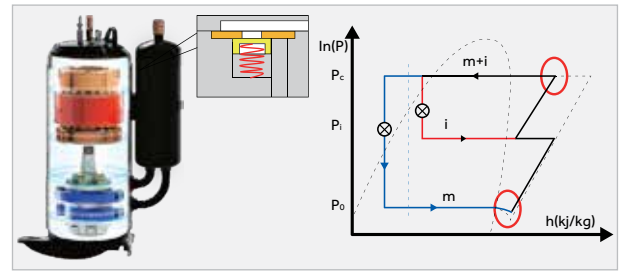

DC fan and fan motor

- DC inverter fan motor more higher efficiency in part load running
- 16-stage speed control; high efficiency running especially in low speed
- Efficiency increase 45% comparing with AC motor and power input largely decrease
- Big diameter fan
- 570mm big diameter fan, more big air flow and more higher efficiency(8/10/12HP)

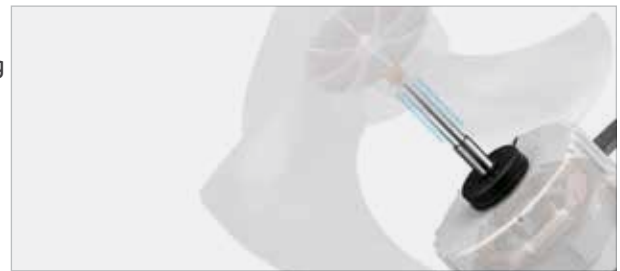

Upgraded configuration, upgraded performance (8/10/12HP Side Discharge)

Bigger outdoor capacity, more flexible application

High efficiency DC fan motor

- DC fan motor with stepless inverter control, efficiency increase 45% comparing with AC motor and power input largely decrease

Large diameter fan

- Ø570mm big diameter axial flow fan
- Zigzag design, reduce airflow disturbance, air volume is bigger, the noise is lower

High efficiency condenser

- New type high efficiency Ø7 inner grooved tube
- New hydrophilic corrugated fissure fin, high efficiency

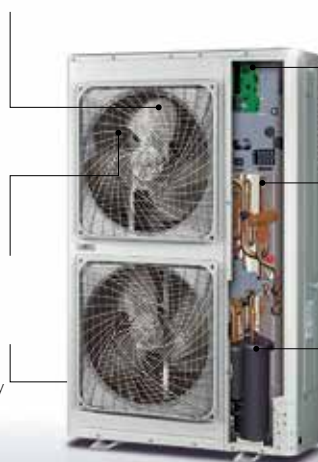

Vector inverter control

- 180 degrees sine wave vector control, 64-bit operation
- High precision control, to achieve high efficiency and lower noise

Double pressure sensor

- Equipped with high and low voltage Pressure double sensors
- Accurate Pressure control, the system run more smoothly, more energy efficiency

Twin rotary DC Inverter compressor

- High chamber DC INVERTER twin rotary compressor
- Small vibration, low noise, high energy efficiency

Indoor units and outdoor units self-cleaning

Indoor units and outdoor units cleaning mode conversion with nonstop, make abundant use of ODU waste heat to IDU defrosting. At the same time, the IDU uses the waste heat of the ODU to defrost the heat exchanger, to dry the condensed water, effectively prevent mold breeding.

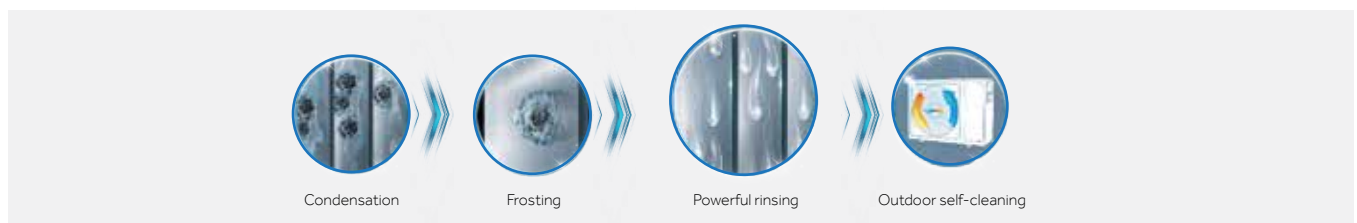

HIGH EFFICIENCY

High energy efficiency

DC inverter compressor

Haier takes DC INV. compressor, 5% power input lower. (14kW)

DC fan motor and 550mm big fan

38% power input lower and 8% airflow higher

Larger heat exchanger

Heat exchange area rise 10%

Low noise level

Night Quiet Operation Function

Noise can be reduced to 45dB(A).

Charge Valve

Built-in charge valve enables safer and easier maintenance

Low standby power

New PCB programme, reduce 20% standby power consumption

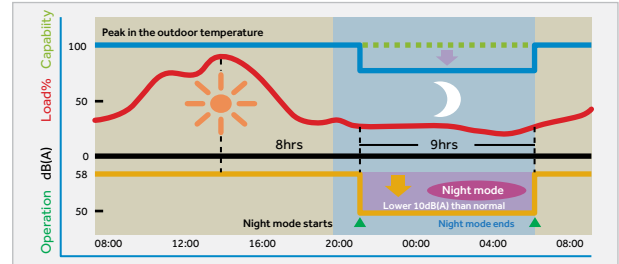

New DC inverter twin rotary compressor

- Small torque change, good dynamic balance, the system runs stably, little vibration, low noise, high efficiency.
- More higher efficiency in part load running.

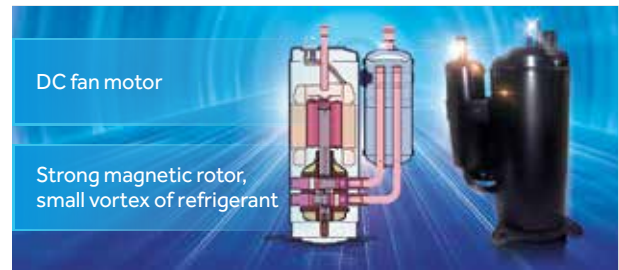

SUPER COMFORT

- 1 New aerodynamics fan 550mm super big diameter aerospace helix fan. lowering sound level 3dB(A).
- 2 Enlarged air inlet path and spiral air outlet path Air flow direction follows the grill direction. lowering sound level 2-4 dB(A).
- 3 Automatic sound-lowering programme Night mode set by PCB, 8dB(A) lower.

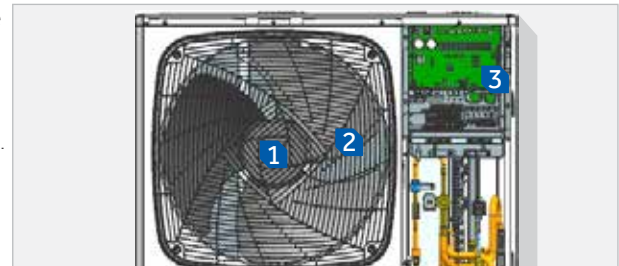

Low noise operation

- DC INVERTER compressor, smooth operation, no need frequent start the compressor, effectively reduce the noise outdoor.
- Vector inverter control, more precise control.
- DC fan motor, motor bracket used the non-resonance structure, ensure smooth running of the motor, reduce operating noise.
- Big diameter fan, design according to aviation quieter principle.



Easy installation

Compact Side Discharge Design, Big Capacity, Small Footprint / Small footprint, only 0.42m², 43% floor area can be reduced.



EASY INSTALLATION

- 1 Double side "4" handles**
Easy to carry
- 2 "888" test panel**
All running data & error code can be checked from "888" screen, which is easy for installers
- 3 "Four-way" pipe connection**
4-way (front, back, left & right) pipe connection, easy to design and install



Compact side discharge design

No need additional ventilation hood comparing with top discharge unit.



Long pipe length, high height drop

- Total pipe length: 300m.
- Single pipe length: Max.175m.
- From outdoor to the first branch pipe: 135m.
- From the first branch to the farthest indoor door unit: 40m.
- Height drop: 50m(outdoor above)/40m (outdoor below).
- Height drop between indoor units: 15m.



Separate refrigerant charging valve

Easy for refrigerant charging.

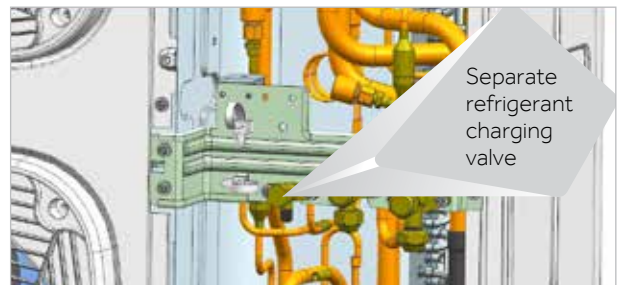

Parameter display panel

The first original parameter display panel on the side. The parameter can be observed directly by opening the protective cover in case of maintenance, to avoid removing the repair board.



Easy maintenance for control

The control box is in front, reserving space 108mm between control box and top panel, easy maintenance from the top. Control box is with hinge design, easy to open for maintenance(8/10/12HP).

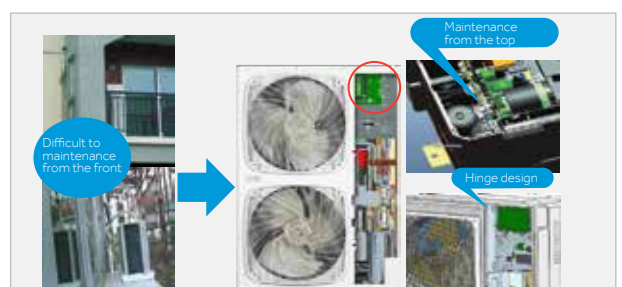

✓ HIGH RELIABILITY

Refrigerant automatically reclaim Technology

Set refrigerant automatically reclaim through dip switch, the refrigerant in indoor and pipe can be automatically return to outdoor, convenient in maintenance and reducing waste of refrigerant, reduce customer maintenance cost, improve the efficiency of after-sales maintenance.

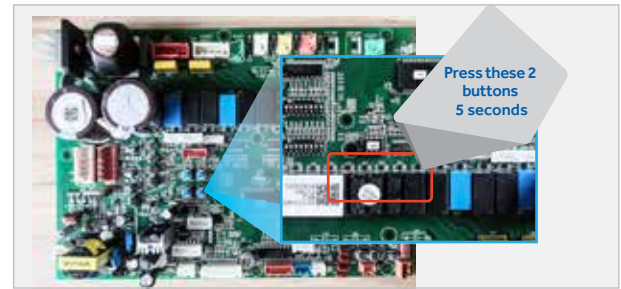

Refrigerant control technology

Refrigerant control technology without high pressure accumulator, reducing the refrigerant volume and enhancing the running efficiency.

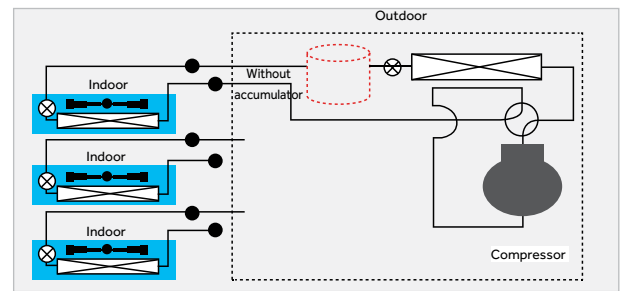

Air inlet grill design on right side panel

Air inlet grill design, reducing the module temperature and avoid air dust into air conditioner.

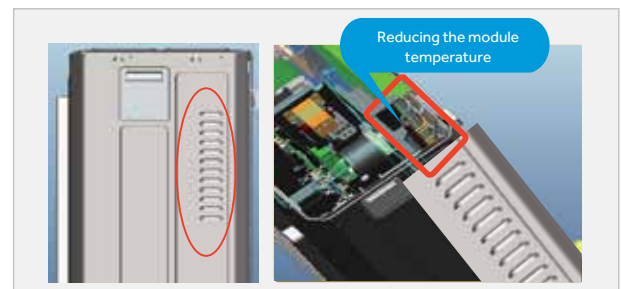

High and low double pressure sensor

- Double pressure sensor with PID control technology.
- Together with high speed communication to realize the quick start of compressor and more precise control, the temperature can be control $\pm 0.5^{\circ}\text{C}$.



MRV S^{II}



- ☀️ AU042FPERA
- ☀️ AU052FPERA
- ☀️ AU062FPERA

Model			AU042FPERA	AU052FPERA	AU062FPERA
Capacity ⁽¹⁾	Capacity range	HP	4	5	6
	Cooling	kW	12.1	14	15.5
	Heating	kW	12.1	14	15.5
	SEER(T1)	/	6.82	6.65	6.80
	η s.c	%	270	263	269
	SCOP(T1)	/	4.05	4.11	4.05
	η s.h	%	159	161	159
Electrical parameters	Power supply	Ph/V/Hz	1/220-240/50/60	1/220-240/50/60	1/220-240/50/60
	Rated power input (Cooling)	kW	3.61	4.33	5.17
	Rated power input (Heating)	kW	3.23	3.76	5.00
Dimensions	External(W/D/H)	mm	950/370/1350	950/370/1350	950/370/1350
	Shipping (W/D/H)	mm	1023/483/1492	1023/483/1492	1023/483/1492
Weight	Net/Shipping	kg	108/123	108/123	108/123
Compressor	Compressor type	/	Rotary	Rotary	Rotary
	Motor power	W	4130	4130	4130
	Compressor quantity	/	1	1	1
Fan	Air flow (H)	m ³ /h	7200	7200	7200
Pressure sound level	Cooling	dB(A)	57	58	59
	Heating	dB(A)	57	58	59
Refrigerant	Type	/	R410A	R410A	R410A
	Charge	kg	4	4	4
Piping	Refrigerant liquid pipe	mm	9.52	9.52	9.52
	Refrigerant gas pipe	mm	15.88	15.88	15.88
	Total pipe length	m	300	300	300
	Max. pipe length (Equivalent/Actual)	m	175/150	175/150	175/150
	Max drop between IDU&ODU (ODU above/below)	m	50/40	50/40	50/40
	Max drop between IDU & IDU	m	15	15	15
Connection ratio	Connectable indoor unit ratio	%	50-130	50-130	50-130
	Maximum number of indoor units	/	8	10	13
Working temp.	Cooling	°C	-5~50	-5~50	-5~50
	Heating	°C	-20~27	-20~27	-20~27

(1) All the specifications are tested under nominal condition as per Eurovent conditions (In cooling, Indoor temp is 27°C DB/19°C WB; Outdoor temp 35°C DB/24°C WB; In heating, Indoor temp is 20°C DB, Outdoor temp is 7°C DB/6°C WB)

MRV S^{II}



- AU08NFKERA
- AU10NFKERA
- AU12NFKERA

Model			AU08NFKERA	AU10NFKERA	AU12NFKERA
Capacity ⁽¹⁾	Capacity range	HP	8HP	10HP	12HP
	Cooling	kW	22.6	28	31.5
	Heating	kW	22.6	30.5	31.5
	Heating(Max)	kW	25	32	35
	SEER	/	7.67	7.65	7.47
	η s.c	%	304	303	296
	SCOP	/	4.05	4.16	4.21
	η s,h	%	159	163.4	165.4
Electrical parameters	Power supply	Ph/V/Hz	3/380-415/50/60	3/380-415/50/60	3/380-415/50/60
	Rated Power input (Cooling)	kW	6.95	8.67	11.52
	Rated Power input (Heating)	kW	5.79	8.03	8.49
Dimensions	External (W/D/H)	mm	1050/400/1636	1050/400/1636	1050/400/1636
	Shipping (W/D/H)	mm	1150/510/1790	1150/510/1790	1150/510/1790
Weight	Net/Shipping weight	kg	149/168	149/168	149/168
Compressor	Compressor type	/	Inverter Twin Rotary	Inverter Twin Rotary	Inverter Twin Rotary
	Motor Power	W	6270	6270	6270
	Compressor quantity	/	1	1	1
Fan	Air flow (H)	m ³ /h	10000	10000	10000
Pressure sound level	Cooling	dB(A)	63	64	65
	Heating	dB(A)	65	66	67
Refrigerant	Type	/	R410A	R410A	R410A
	Charge	kg	5.1	5.1	5.1
Piping	Refrigerant liquid pipe	mm	9.52	9.52	12.7
	Refrigerant gas pipe	mm	19.05	22.22	25.4
	Total pipe length	m	300	300	300
	Max. pipe length(Equivalent/Actual)	m	175/150	175/150	175/150
	Max drop between I.U.&O.U.(ODU above / below)	m	50	50	50
	Max drop between I.U.&I.U.	m	15	15	15
Connection ratio	Connectable indoor unit ratio	%	50-130	50-130	50-130
	Maximum number of indoor units	/	13	16	19
Working temp.	Cooling	°C	-5-48	-5-48	-5-48
	Heating	°C	-20-27	-20-27	-20-27

(1) All the specifications are tested under nominal condition as per Eurovent conditions (In cooling, Indoor temp is 27°C DB/19°C WB; Outdoor temp 35°C DB/24°C WB; In heating, Indoor temp is 20°C DB, Outdoor temp is 7°C DB/6°C WB)

Dimensions

AU042FPERA AU052FPERA AU062FPERA AU04IFPERA AU05IFPERA AU06IFPERA

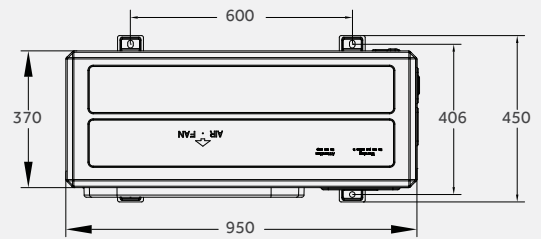
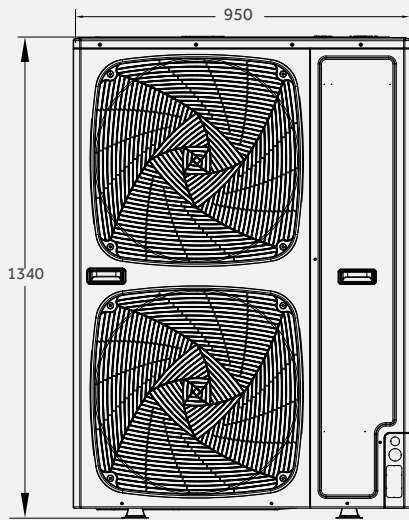

AU08NFKERA AU10NFKERA AU12NFKERA

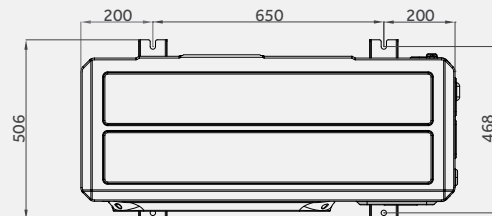
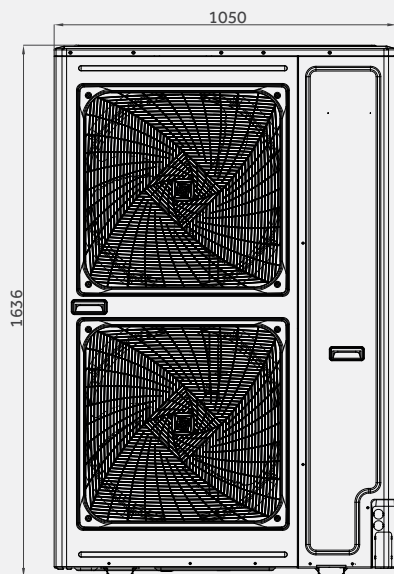



System Introduction



Unit structure



MRV AHU Connection Kit

037 The 2nd Generation AHU Kit

040 Specification

040 Dimensions



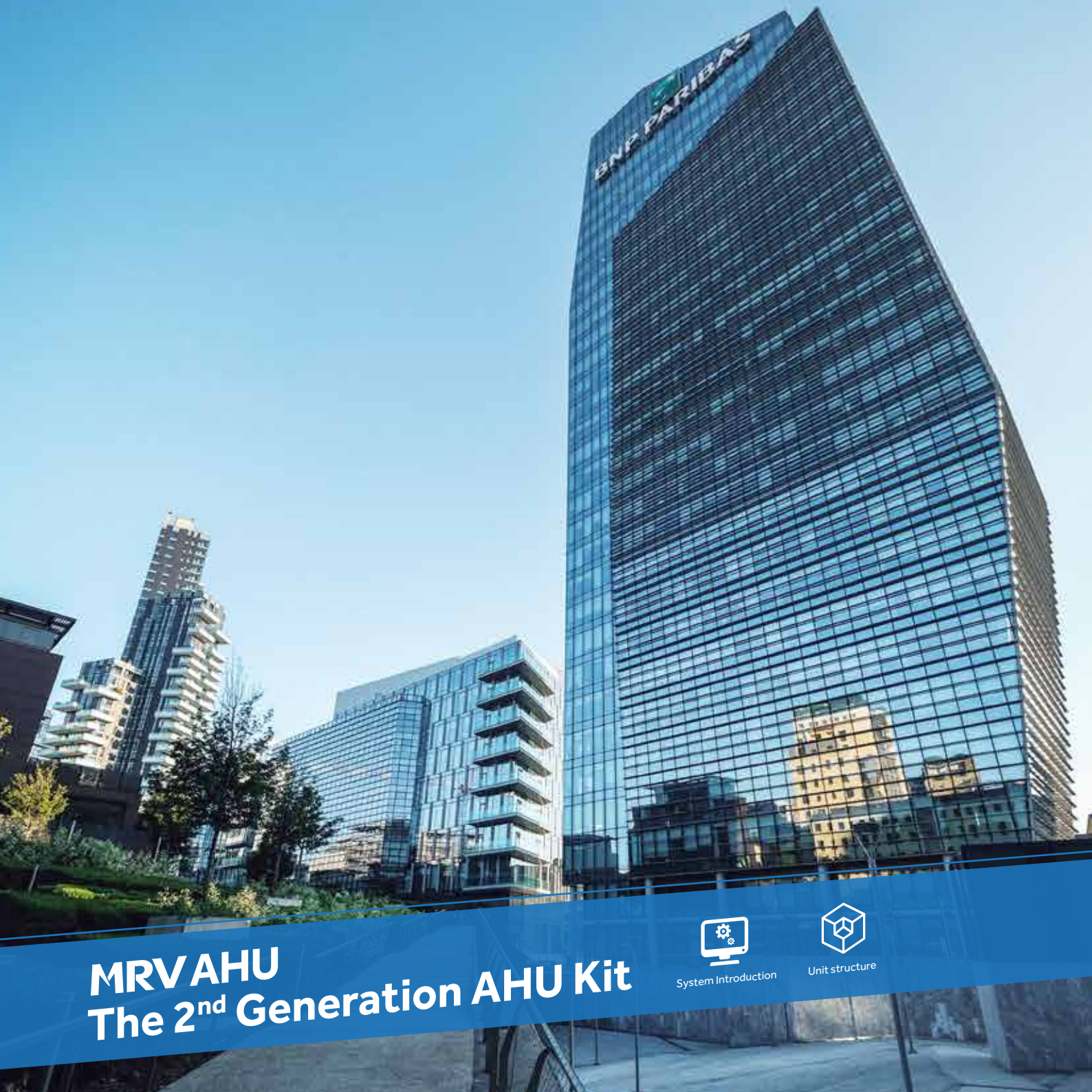

MRV AHU The 2nd Generation AHU Kit



System Introduction



Unit structure

SYSTEM INTRODUCTION

System introduction

Haier offers a range of connection kit to connect MRV outdoor units to third party DX air handling units.

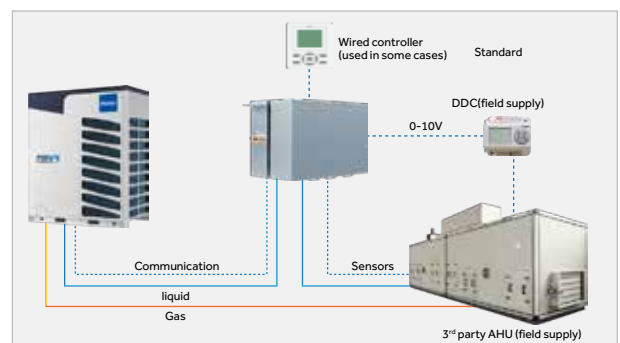

SYSTEM INTRODUCTION

Ahu kit configuration

Haier 2nd generation AHU kit also contains the following 4 parts: The Controller model is HW-AA 101DBK, special for Haier 2nd generation AHU kit as standard accessory, no need to be purchased separately.

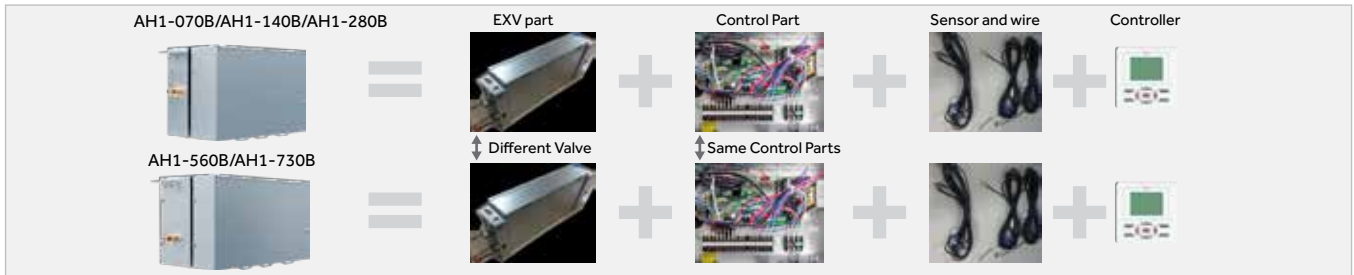

System line-up

Haier AHU kit provides a wide range solution for Haier MRV outdoor unit connecting with the 3rd party AHU.

DX AHU ² Connection kit					Special design for MRV 5 , MRV SII	
Model	AH1-070B	AH1-140B	AH1-280B	AH1-560B	AH1-730B	
Capacity	3.5<Connected AHU capacity≤7kW	7<Connected AHU capacity≤14kW	14<Connected AHU capacity≤28kW	28<Connected AHU capacity≤56kW	56<Connected AHU capacity≤73kW	
Compatibility						
Outdoor	MRV5-RC			MRV S ^I		
	<p>Only suitable for heat pump HP→8-20</p>					
HP	8-26			4	5	6
Power supply	3Ph/380-415V/50/60Hz			1Ph/220-230V/50/60Hz		3Ph/380-400V/50/60Hz
				8	10	12
AHU & MRV indoor	<p>AHU need purchase in Market</p>					

Control solutions

Four control methods can be used, which can be switched by dip switch based on the site scenario.

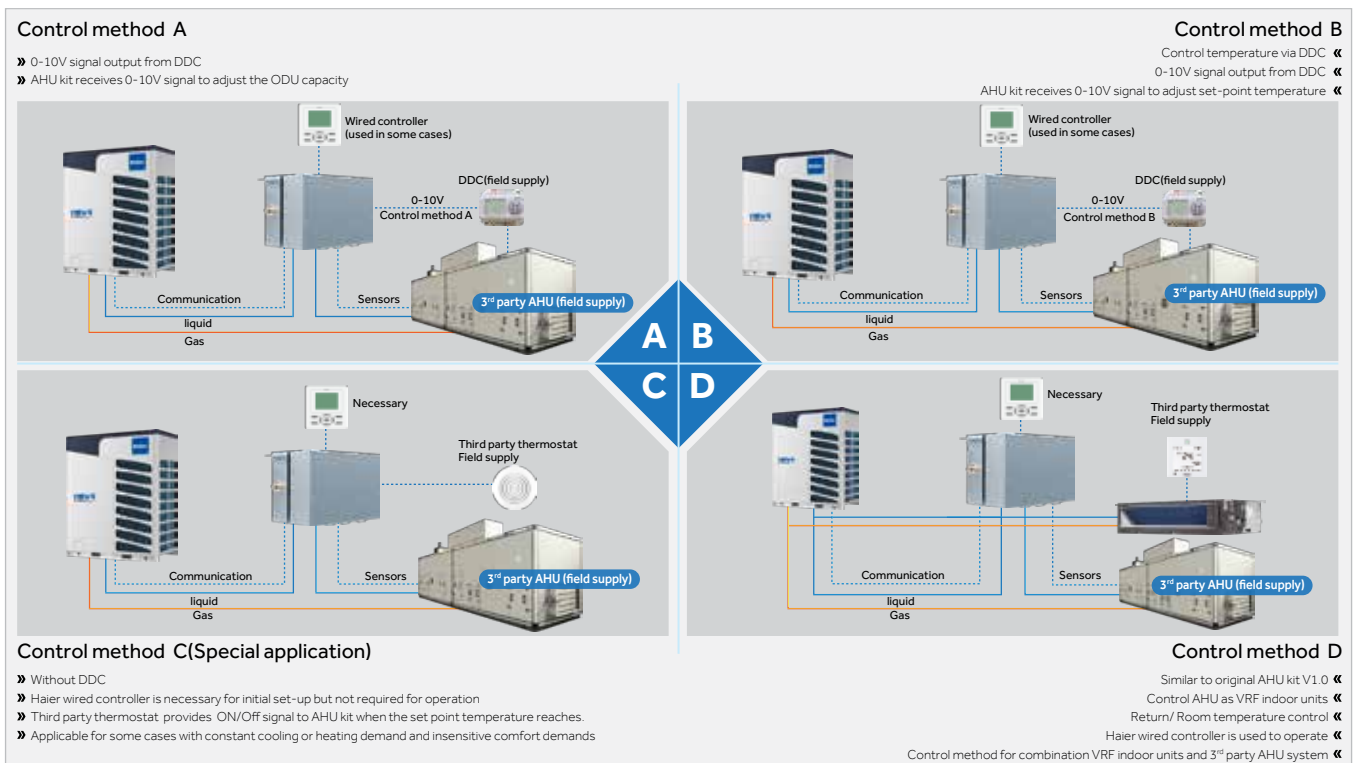

SYSTEM INTRODUCTION

Central control

Note:

- MRV 5 and upgraded MRV SII(8/10/12HP can directly connect with central controller HC-SA164DBT and YCZ-A004.
- Other MRV systems need the HA-MA164AD gateway.
- For new webserver controller, the new gateway HA-MA1ADB.
- For control method A,B,C of AHU kit, only monitoring the AHU is available and unable to conduct control operation.
- For control solution D of AHU kit, AHU can be controlled as one MRV indoor unit, both monitoring and control operations are available.



YCZ-A004



HC-SA164DBT

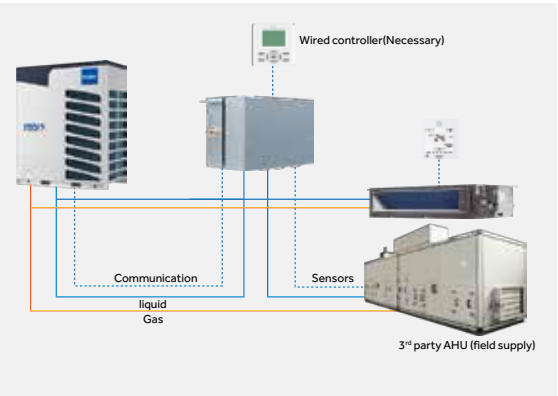

Bms control

Note:

- Integrate Haier remote monitoring and controlling system via PC and BMS interface
- HCM-01A:Modbus rtu
- HCM-03A:Modbus ip/ Bacnet ip
- HCM-05: BACnet ip



HCM-01A



HCM-03A



HCM-05

Note:

- Only have BMS interface without Haier remote monitoring system
- HA-MA164AD:Modbus.For MRV 5 and upgraded MRV SII (8/10/12HP) integrates this function
- HCM-04:Bacnet
- IGU07:Lonworks



HA-MA164AD



HCM-04



IGU07

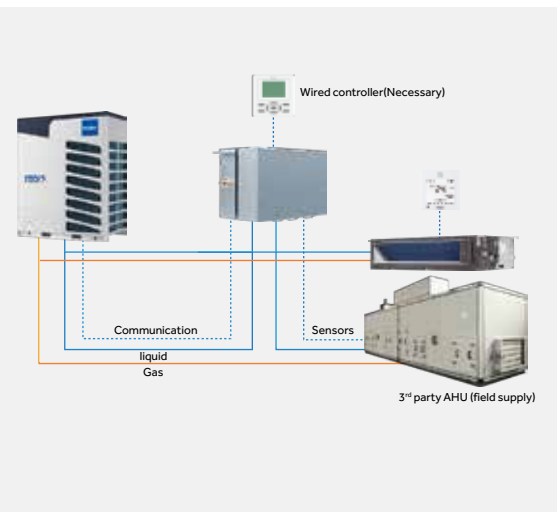

UNIT STRUCTURE

Features

- Extend the AHU connected capacity of per kit ranging from 3.5 kW to 73kW, which can meet the small, medium and large buildings demands.
- Add the 0-10V signal control.
- Supply air temperature (from DDC) or return air temperature controllable.
- Remove the gas pipe, more convenient for installation.

The 2nd generation AHU kit VS The 1st generation AHU kit

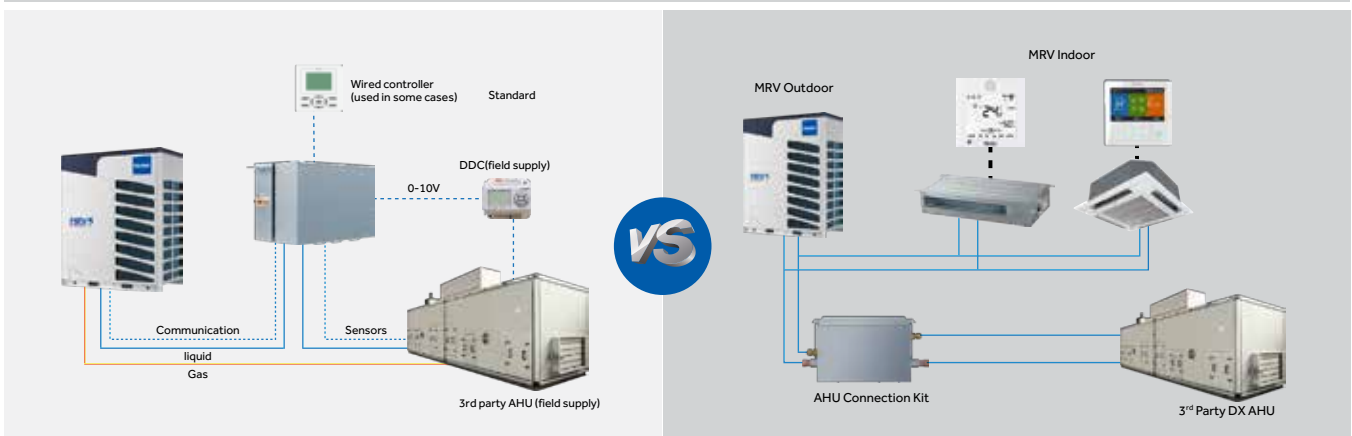

SPECIFICATION

Model	AH1-070B	AH1-140B	AH1-280B	AH1-560B	AH1-730B
Connected	3.5≤X≤7KW	7<X≤14KW	14<X≤28KW	28<X≤56KW	56<X≤73KW
AHU capacity	(1-3HP)	(3-5HP)	(5-10HP)	(10-20HP)	(20-26HP)
Power Supply (Ph/V/Hz)	1/220-240/50/60	1/220-240/50/60	1/220-240/50/60	1/220-240/50/60	1/220-240/50/60
Dimension (W/D/H) (mm)	420/260/165	420/260/165	420/260/165	420/260/215	420/260/215
Shipping dimensions (mm)	520/340/225	520/340/225	520/340/225	520/340/275	520/340/275
Material	Galvanized steel	Galvanized steel	Galvanized steel	Galvanized steel	Galvanized steel
Color	Grey	Grey	Grey	Grey	Grey
Weight (KG)	5.5	5.5	5.5	6.5	6.5
Shipping Weight (KG)	8.5	8.5	8.5	10	10
Liquid pipe (mm)	9.52 (Main) / 6.35	9.52 (Main) / 6.35	9.52 (Main) / 6.35	12.7 (Main) / 15.88	12.7 (Main) / 15.88
AHU Kit-3rd party AHU Max Single pipe length (m)	5	5	5	5	5
AHU Kit-3rd party AHU Max Single pipe length (m)	5	5	5	5	5

AH1-070B AH1-140B AH1-280B

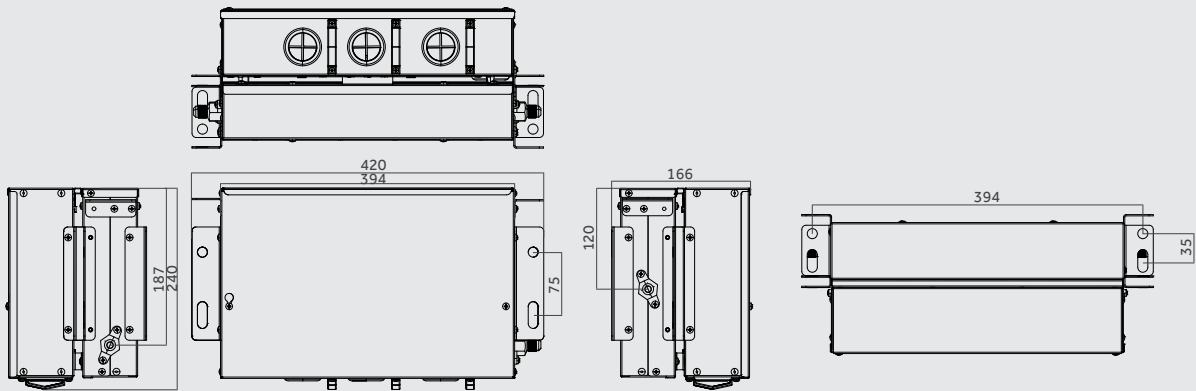

AH1-560B AH1-730B

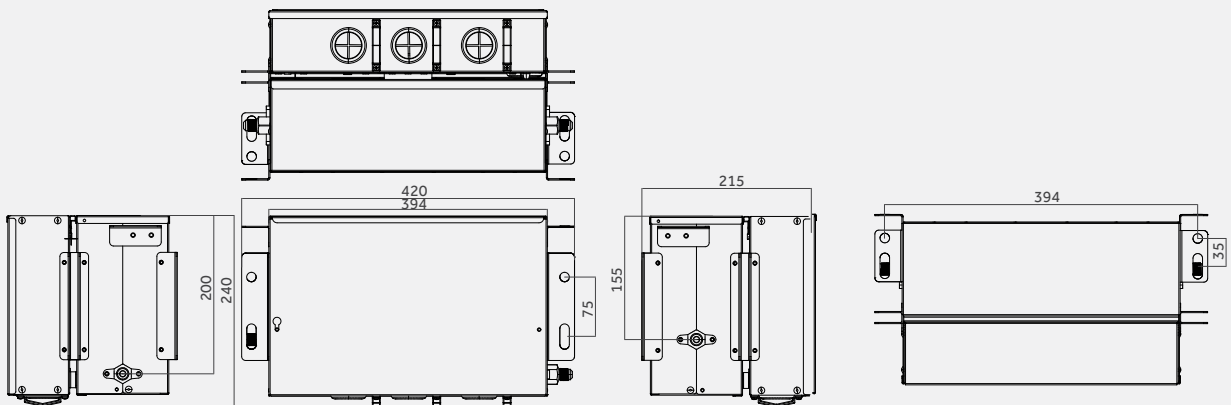



MRV INDOOR



Cassette



Duct



High Wall



043 Features

051 1-Way Cassette

053 Compact Cassette

055 Round Way Cassette

057 Slim Duct

059 High ESP Duct (20/200Pa)

061 High ESP Duct (100/250Pa)

063 High Wall

071 Dimensions



1-Way Cassette

New butterfly wing air supply, 5 step fan speed is optional, enjoy healthy air

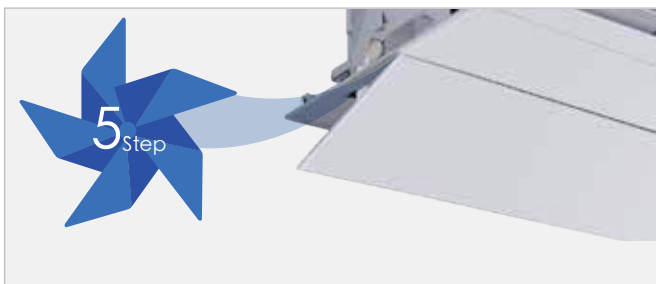

High ceiling design the air reaches the ground

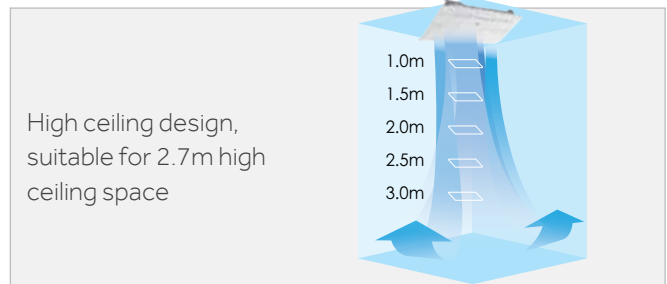

Standard condensate water lifting pump

Equipped with 700mm drain pump, built-in float switch, convenient according to the actual working situation, Discharge condensate water from air conditioner.

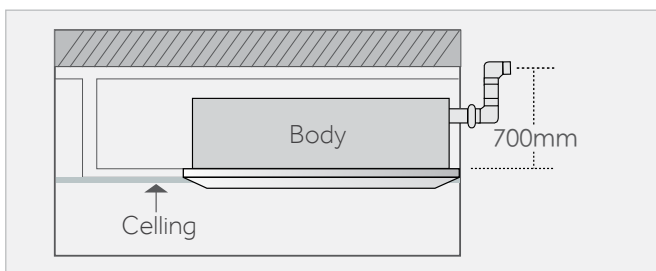

Super wide angle air supply comfortable enjoy

Adopt new DC motor, equipped with up and down, left and right swing wind motor, realize intelligent swing wind control and ultra wide Angle air supply range, enjoy comfortable air.

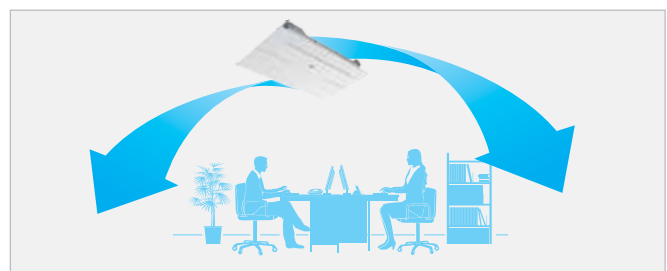

Suitable for corner installation for comfortable and uniform air supply

Compact design, full use of corner space installation, such as small meeting rooms, corridorsetc.; The indoor machine is located in the ceiling, and the panel adopts the integrated design, which is generous and beautiful. Suitable for long and narrow rooms, to ensure the uniform distribution of air flow and room temperature.





Round Way Cassette

Free air supply and flexible control to enjoy a comfortable environment

The outlet adopts stepper motor design to realize the four-direction independent control system.



Quiet operation, create a peaceful space

- High efficiency brushless DC fan motor, achieve step-less adjustment for speed, greatly reduce the noise of operation.
- Optimize the traditional air duct design, adopt sound insulation wall technology, effectively reduce the eddy current range, block the transmission path of noise, effectively reduce the noise about 3dB(A).
- Fan optimization design, using the principle of fluid mechanics, referring to the design of aviation structure, so that the airflow speed distribution is uniform, reduce the airflow resistance, so as to reduce noise, to achieve quiet operation. Note: * Other ac motor standards are optional.



Standard drain pump

Standard drain pump, the lift is 700mm and built-in float switch, convenient to cooperate with the actual situation to condensate water discharge air conditioning.

Antibacterial Filter



Streamlined outlook design

Buy a traditional grille and a dynamic windmill for multi-choice and multi-enjoyment. Buy a dynamic windmill to enjoy a dynamic mood and relax in the wind.



Energy saving control

The product adopts MOVE EYE module (optional), which can be controlled to realize the function of switch-on when people coming in and switch-off when people leaving.

Thinner design, easy installation No restriction on hoisting direction Separation of strong and weak current, high reliability



Slim Duct

Adjusted ESP super slim save installation space agile and convenient

Fuselage thickness of only 180mm, easy to install in the height of narrow residential ceiling, fuselage depth of only 450mm, save the ceiling area, and fully cooperate with the interior decoration.

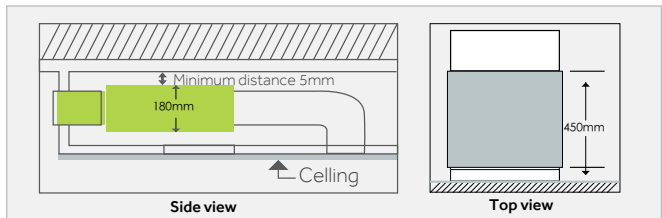

Quiet operation

- High efficiency model * High efficiency brushless DC motor, speed stepless adjustment, can achieve seven air supply, greatly reduce operating noise.
- Through the reasonable design of indoor unit thermal components and internal air duct, four block wind speed, silent operation is realized. Note: The standard model of AC motor is also available.

High lift-up drain pump

Standard condensate water lifting pump, standard head 700mm, special models customized range up to 1200mm, and built-in float switch, convenient to cooperate with the actual situation of the site, condensate water discharge air conditioning.

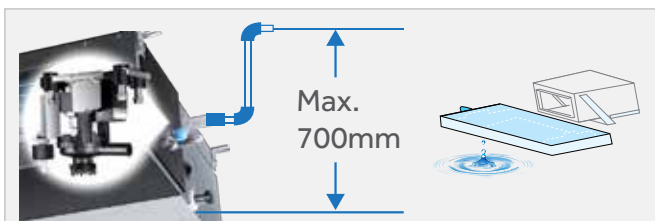

Antibacterial Filter



Return air mode selection according to local conditions -- more user-friendly installation

Provide bottom and rear two return air modes, indoor installation more flexible and convenient, users can choose the best installation scheme according to the characteristics of interior decoration. Note: If there is enough installation space, it is recommended to use the side feed back mode, which can effectively reduce the running sound.

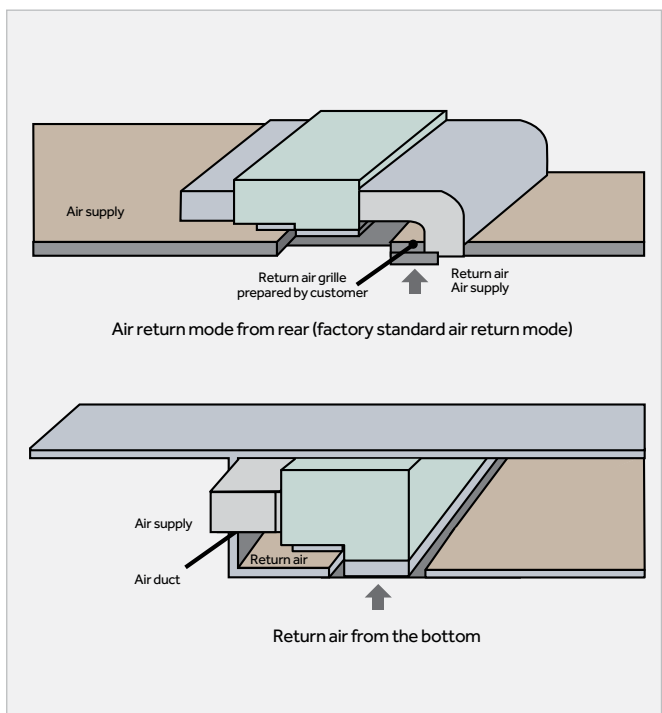



3D Three-dimensional Air Supply

With makings fastidious

Air guide plate, shutter adopts PC+ABS, high temperature resistance, not easy to deformation, color and luster lasting.

Sympathetic function

The panel parameters are displayed in invisible mode, which makes it softer. The temperature display and color transformation of refrigeration and heating are green and red, which are more classy.



Details of the outstanding using at ease

The air inlet grille can be dismantled and cleaned by pulling the buckle, which is more convenient.

Fashionable and beautiful

Streamline design, automatic shutdown, no ash accumulation, beautiful atmosphere, hidden installation and home decoration perfect combination, highlight grade.



The horizontal louver is driven by two motors, which makes it easier to run.



Vertical louvers are driven by an electric motor and run freely.

3D three-dimensional air supply

- Pendulum blade two motor control, vertical louver one motor control, easy to operate.
- Free swing wind between 30-80 degrees up and down, swing wind around 90 degrees, 3D three-dimensional air supply, wide Angle of air supply.



Medium and High ESP DUCT

Static pressure optional, meet different needs

According to users requirements, the static pressure can be adjusted by wire controller instead of the traditional way of changing the red and white terminals. The maximum static pressure of the whole series can reach 200Pa.

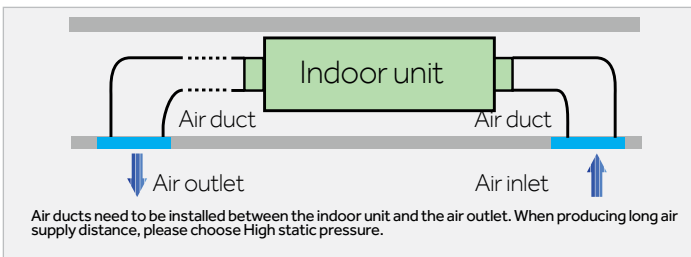

Antibacterial Filter

Silver (Ag) is a natural antibacterial material, which has good broad-spectrum antibacterial properties and could motivate bacterial extinction.

Haier antibacterial filter has added silver ions and antibacterial organics to kill Escherichia coli & Staphylococcus aureus effectively, with long lasting effects.



Air duct connection more room to share

The unit can connect multiple rooms through air duct, and can be flexibly arranged according to different house types, one air conditioner, multi-room sharing.



Hidden design, more beautiful

Thin height design, the unit can be easily placed in the ceiling, only the air outlet exposed, can not feel the existence of indoor unit, so that the indoor space suddenly open.



Free setting air outlet humanization setting

Due to the use of pipe air supply, according to the room environment and user requirements to freely choose the number of air outlet and installation position, fully consider the load of the room and room temperature balance, to achieve a more perfect and comfortable feeling.



High lift-up drain pump

Standard condensate water lifting pump, standard head 700mm, special models customized range up to 1200mm, and built-in float switch, convenient to cooperate with the actual situation of the site, condensate water discharge air conditioning.

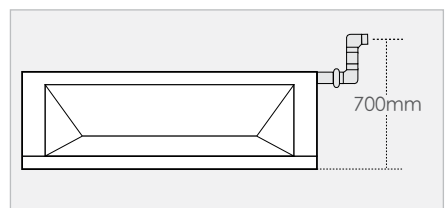



High ESP Duct

High static pressure design, more room to share

The external static pressure can achieve 200Pa, and the air duct can be freely selected. Do an air conditioning, multi-room sharing.

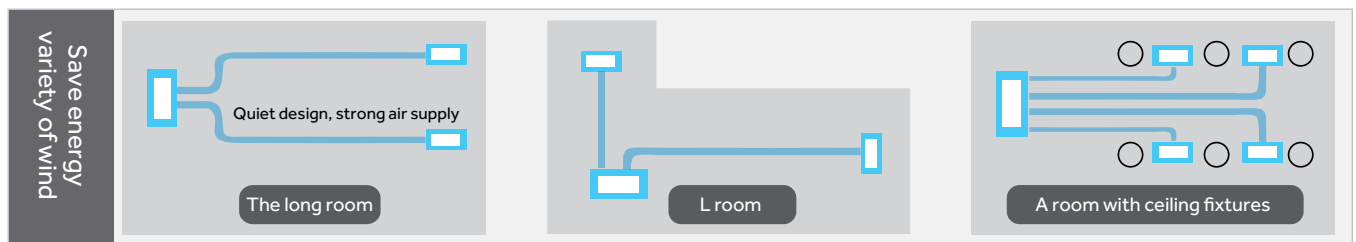

Antibacterial Filter

Silver (Ag) is a natural antibacterial material, which has good broad-spectrum antibacterial properties and could motivate bacterial extinction. Haier antibacterial filter has added silver ions and antibacterial organics to kill Escherichia coli & Staphylococcus aureus effectively, with long lasting effects.



Silence design

- Adopt international new sound insulation noise reduction materials, pressure off mute wind wheel.
- Prevents indoor pollution and provides maximum wind speed, ensuring air circulation throughout the room.
- 5 speed adjustable fan speed to meet different needs.

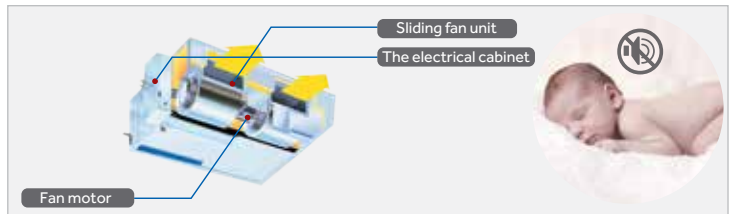

Multiple installation way, flexible optional

- Air duct air conditioning has a variety of free and optional installation.
- Flexible customization according to the house type and user needs, to meet the high taste of the room Settings.





High Wall

Built-in electronic expansion valve for easy installation

Built-in electronic expansion valve, easy to install. Dc fan motor, multi-wind speed, with multi-stage air supply angle to create comfortable airflow.

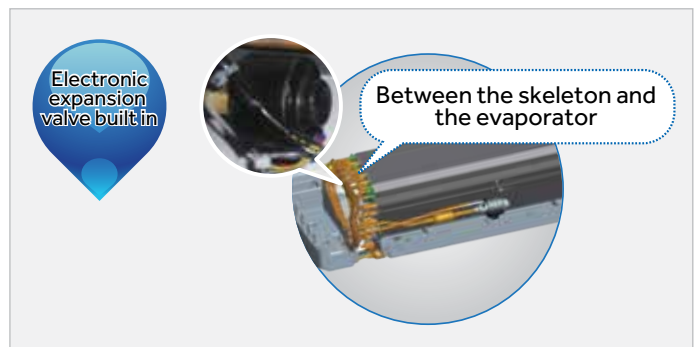

Flexible wind control, quick cooling and heating

In heating and cooling condition, the unit can supply large volume air to quick warm and cold everywhere of indoor room.

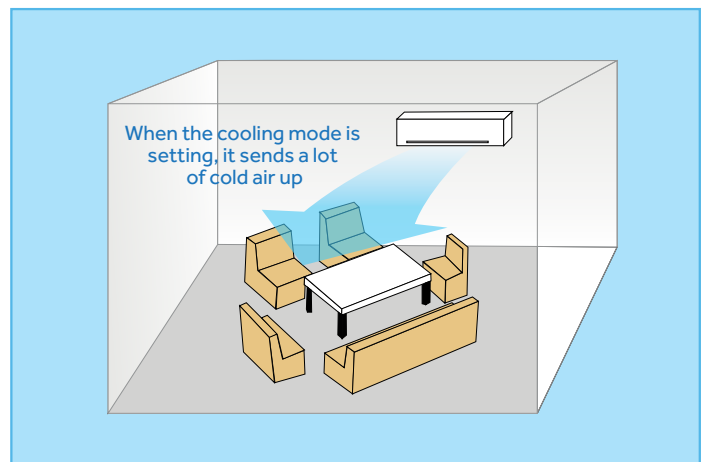
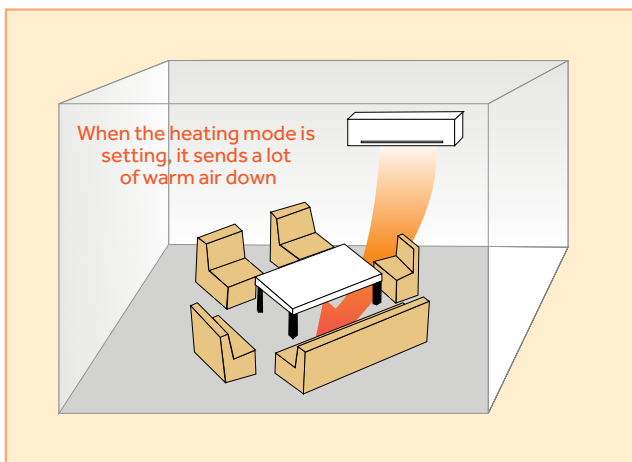



1-Way CASSETTE



HW-BA116ABK



YR-E17A



HW-BA101ABT



YR-E16B



YR-HRS01



DC fan motor



Ultra thin design 185mm



Butterfly wings airflow



Built-in high head drain pump maxl. 1000mm

Model/Indoor unit			AB052MAERA	
Capacity	Cooling	kBtu/h	5.1	
		kW	1.5	
	Heating	kBtu/h	5.8	
		kW	1.7	
Electrical Parameters	Power supply	Ph/V/Hz	1/220-230/50/60	
	Air flow (H/M/L)	m ³ /h	530/490/450	
Performance	Sound pressure level(H/M/L)	dB(A)	32/29/24	
	Sound power level(H/M/L)	dB(A)	46/43/38	
	Installation	External dimensions(W/D/H)	mm	875/505/185
Shipping dimensions(W/D/H)		mm	1028/581/270	
Net/Shipping weight		kg	15.3/17.9	
Refrigerant liquid pipe		mm	6.35	
Refrigerant gas pipe		mm	9.52	
Panel	Model Name		P1B-1050B	
	External dimensions(W/D/H)	mm	1050/560/122	
	Shipping dimensions(W/D/H)	mm	1133/623/197	
	Net/Shipping weight	kg	5.3/8.3	
Controller	Wired(Optional)	/	HW-BA101ABT	
		/	YR-E16B	
		/	HW-BA116ABK	
		/	YR-E17A	
	Infrared (Optional)	/	YR-HRS01	



1-Way CASSETTE

AB072MAERA	AB092MAERA	AB122MAERA
7.5	9.6	12.3
2.2	2.8	3.6
8.5	10.9	13.6
2.5	3.2	4
1/220-230/50/60	1/220-230/50/60	1/220-230/50/60
530/490/450	530/490/450	550/530/490
32/29/24	32/29/24	34/30/25
46/43/38	46/43/38	48/44/39
875/505/185	875/505/185	875/505/185
1028/581/270	1028/581/270	1028/581/270
15.3/17.9	15.3/17.9	15.3/17.9
6.35	6.35	6.35
9.52	9.52	12.7
P1B-1050IB	P1B-1050IB	P1B-1050IB
1050/560/122	1050/560/122	1050/560/122
1133/623/197	1133/623/197	1133/623/197
5.3/8.3	5.3/8.3	5.3/8.3
HW-BA101ABT	HW-BA101ABT	HW-BA101ABT
YR-E16B	YR-E16B	YR-E16B
HW-BA116ABK	HW-BA116ABK	HW-BA116ABK
YR-E17A	YR-E17A	YR-E17A
YR-HRS01	YR-HRS01	YR-HRS01

Compact CASSETTE



YR-E17A

YR-E16B

YR-HRS01

YR-HQS01



DC fan motor



New panel design
620*620mm



Fresh air outlet



Low sound level

Model/Indoor unit			AB052MCERA(M)	
Capacity	Cooling	kBtu/h	5.1	
		kW	1.5	
	Heating	kBtu/h	5.8	
		kW	1.7	
Electrical Parameters	Power supply	Ph/V/Hz	1/220-240/50/60	
	Air flow (H/M/L)	m ³ /h	520/450/400	
Performance	Sound pressure level(H/M/L)	dB(A)	32/30/29	
	Sound power level(H/M/L)	dB(A)	46/44/43	
	External dimensions(W/D/H)	mm	570/570/260	
Installation	Shipping dimensions(W/D/H)	mm	718/680/380	
	Net/Shipping weight	kg	16/19	
	Refrigerant liquid pipe	mm	6.35	
	Refrigerant gas pipe	mm	9.52	
Panel	Model Name		PB-620KB	
	External dimensions(W/D/H)	mm	620/620/60	
	Shipping dimensions(W/D/H)	mm	660/660/115	
Controller	Wired(Optional)	/	YR-E16B	
		/	YR-E17A	
	Infrared (Optional)	/	YR-HQS01	
		/	YR-HRS01	



Compact 
CASSETTE

AB072MCERA(M)	AB092MCERA(M)	AB122MCERA(M)	AB162MCERA(M)	AB182MCERA(M)
7.5	9.5	12.3	15.3	19.1
2.2	2.8	3.6	4.5	5.6
8.5	10.9	13.6	17.1	21.5
2.5	3.2	4	5	6.3
1/220-240/50/60	1/220-240/50/60	1/220-240/50/60	1/220-240/50/60	1/220-240/50/60
520/450/400	520/450/400	520/450/400	650/520/450	760/650/520
32/30/29	32/30/29	33/30/29	33/30/29	34/32/30
46/44/43	46/44/43	47/44/43	47/44/43	48/46/44
570/570/260	570/570/260	570/570/260	570/570/260	570/570/260
718/680/380	718/680/380	718/680/380	718/680/380	718/680/380
16/19	16/19	19/22	19/22	19/22
6.35	6.35	6.35	6.35	6.35
9.52	9.52	12.7	12.7	12.7
PB-620KB	PB-620KB	PB-620KB	PB-620KB	PB-620KB
620/620/60	620/620/60	620/620/60	620/620/60	620/620/60
660/660/115	660/660/115	660/660/115	660/660/115	660/660/115
YR-E16B	YR-E16B	YR-E16B	YR-E16B	YR-E16B
YR-E17A	YR-E17A	YR-E17A	YR-E17A	YR-E17A
YR-HQS01	YR-HQS01	YR-HQS01	YR-HQS01	YR-HQS01
YR-HRS01	YR-HRS01	YR-HRS01	YR-HRS01	YR-HRS01

Round Way CASSETTE

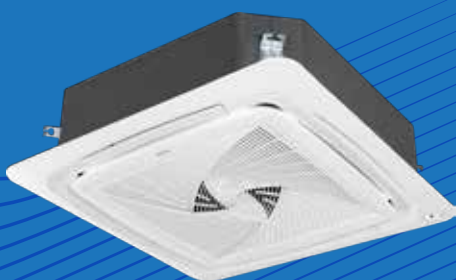

YR-E17A



YR-E16B



YR-HRS01



YR-HQS01



DC fan motor



Unique round-way air outlet, no blind spot



Innovative 4 independent air flow control



6 adjustable louver positions, 1296 air flow combinations

Model/Indoor unit			AB072MRERA	AB092MRERA	
Capacity	Cooling	kBtu/h	7.5	9.5	
		kW	2.2	2.8	
	Heating	Btu/h	8.5	10.9	
		kW	2.5	3.2	
Electrical Parameters	Power supply	Ph/V/Hz	1/220~230/50/60	1/220~230/50/60	
	Air flow (H)	m ³ /h	1000/810/620	1000/810/620	
Performance	Sound pressure level(H/M/L)	dB(A)	30/27/25	30/27/25	
	Installation	External dimensions(W/D/H)	mm	840/840/180	840/840/180
Shipping dimensions(W/D/H)		mm	983/983/268	983/983/268	
Net/Shipping weight		kg	25/28	25/28	
Refrigerant liquid pipe		mm	6.35	6.35	
Refrigerant gas pipe		mm	9.52	9.52	
Panel	Model name		PB-950KB	PB-950KB	
	External dimensions(W/D/H)	mm	950/950/50	950/950/50	
	Shipping dimensions(W/D/H)	mm	1013/1025/123	1013/1025/123	
	Net/Shipping weight	kg	6.5/9	6.5/9	
Controller	Wired(Optional)	/	YR-E17A	YR-E17A	
		/	YR-E16B	YR-E16B	
	Infrared(Optional)	/	YR-HQS01	YR-HQS01	
		/	YR-HRS01	YR-HRS01	



Round Way 
CASSETTE

AB122MRERA	AB162MRERA	AB182MRERA	AB242MRERA	AB282MRERA	AB302MRERA	AB382MRERA	AB482MRERA	AB602MRERA
12.3	15.3	19.1	24.2	27.3	30.7	38.2	47.7	54.6
3.6	4.5	5.6	7.1	8	9	11.2	14	16
13.6	17.1	21.5	27.3	30.7	34.1	42.6	54.6	61.2
4	5	6.3	8	9	10	12.5	16	18
1/220-230/50/60	1/220-230/50/60	1/220-230/50/60	1/220-230/50/60	1/220-230/50/60	1/220-230/50/60	1/220-230/50/60	1/220-230/50/60	1/220-230/50/60
1000/810/620	1000/810/620	1000/810/620	1380/1190/1000	1380/1190/1000	2050/1860/1670	2050/1860/1670	2100/1910/1720	2100/1910/1720
30/27/25	32/29/27	33/30/29	35/34/31	37/35/31	37/35/31	37/35/31	44/40/36	44/40/36
840/840/180	840/840/180	840/840/180	840/840/204	840/840/204	840/840/246	840/840/246	840/840/288	840/840/288
983/983/268	983/983/268	983/983/268	983/983/290	983/983/290	983/983/331	983/983/331	983/983/373	983/983/373
25/28	25/28	25/28	27/30	27/30	31/36	31/36	33/38	33/38
6.35	6.35	6.35	9.52	9.52	9.52	9.52	9.52	9.52
12.7	12.7	12.7	15.88	15.88	15.88	15.88	15.88	15.88
PB-950KB	PB-950KB	PB-950KB	PB-950KB	PB-950KB	PB-950KB	PB-950KB	PB-950KB	PB-950KB
950/950/50	950/950/50	950/950/50	950/950/50	950/950/50	950/950/50	950/950/50	950/950/50	950/950/50
1013/1025/123	1013/1025/123	1013/1025/123	1013/1025/123	1013/1025/123	1013/1025/123	1013/1025/123	1013/1025/123	1013/1025/123
6.5/9	6.5/9	6.5/9	6.5/9	6.5/9	6.5/9	6.5/9	6.5/9	6.5/9
YR-E17A	YR-E17A	YR-E17A	YR-E17A	YR-E17A	YR-E17A	YR-E17A	YR-E17A	YR-E17A
YR-E16B	YR-E16B	YR-E16B	YR-E16B	YR-E16B	YR-E16B	YR-E16B	YR-E16B	YR-E16B
YR-HQS01	YR-HQS01	YR-HQS01	YR-HQS01	YR-HQS01	YR-HQS01	YR-HQS01	YR-HQS01	YR-HQS01
YR-HRS01	YR-HRS01	YR-HRS01	YR-HRS01	YR-HRS01	YR-HRS01	YR-HRS01	YR-HRS01	YR-HRS01

Slim DUCT (0/15/30Pa)



YR-E17A



HW-BA101ABT



YR-E16B



YR-HRS01

- *1. HW-BA116ABK, YR-E17A and HW-BA101ABT have built-in infrared signal receiver. YR-E16B no such function.
2. The units with panel can directly use the remote controller YR-HD and no need to purchase RE-02.

Model/Indoor unit			AD052MSERA(D)	
Capacity	Cooling	kBtu/h	5.1	
		kW	1.5	
	Heating	kBtu/h	5.8	
		kW	1.7	
Electrical Parameters	Power supply	Ph/V/Hz	1/220~230/50/60	
	Air flow (H/M/L)	m ³ /h	430/370/310	
Performance	Sound pressure level(H/M/L)	dB(A)	26/22/19	
	Sound power level(H/M/L)	dB(A)	40/36/33	
	External dimensions(W/D/H)	mm	850/420/185	
Installation	Shipping dimensions(W/D/H)	mm	1045/540/270	
	Net/Shipping weight	kg	16.5/21.5	
	Refrigerant liquid pipe	mm	6.35	
	Refrigerant gas pipe	mm	9.52	
	Static Pressure(Standard/Max.)	Pa	0/15/30	
Panel	Panel model	/	P1B-890IA/D	
	External dimensions(W/D/H)	mm	890/190/100 (outlet panel)	
	External dimensions(W/D/H)		890/290.5/32.4 (inlet panel)	
	Shipping dimensions(W/D/H)	mm	938/335/220	
	Net/Shipping weight	Kg	4/5	
Drain pump	O-optional, S-standard, W-without		S	
Controller		/	HW-BA101ABT	
	Wired(Optional)	/	YR-E16B	
		/	YR-E17A	
	Infrared (Optional)	/	YR-HRS01	



DC fan motor



Super slim design,
only 185mm



Friendly design of rear or
bottom air return



Built-in high head drain pump



Slim DUCT[®] (0/15/30Pa)

AD072MSERA(D)	AD092MSERA(D)	AD122MSERA(D)	AD162MSERA(D)	AD182MSERA(D)	AD242MSERA(D)
7.5	9.5	12.3	15.3	19.1	24.2
2.2	2.8	3.6	4.5	5.6	7.1
8.5	10.9	13.6	17.1	21.5	27.3
2.5	3.2	4	5	6.3	8
1/220~230/50/60	1/220~230/50/60	1/220~230/50/60	1/220~230/50/60	1/220~230/50/60	1/220~230/50/60
480/420/360	480/420/360	550/430/370	600/540/460	800/690/580	930/850/750
27/23/20	27/23/20	30/27/24	32/29/26	33/30/27	36/33/30
41/37/34	41/37/34	44/41/38	46/43/40	47/44/41	50/47/43
850/420/185	850/420/185	850/420/185	850/420/185	1170/420/185	1170/420/185
1045/540/270	1045/540/270	1045/540/270	1045/540/270	1365/540/270	1365/540/270
17.5/22.5	17.5/22.5	17.5/22.5	18.5/23.5	22.2/28.2	24/30
6.35	6.35	6.35	6.35	6.35	9.52
9.52	9.52	12.7	12.7	12.7	15.88
0/15/30	0/15/30	0/15/30	0/15/30	0/15/30	0/15/30
P1B-890IA/D	P1B-890IA/D	P1B-890IA/D	P1B-890IA/D	P1B-1210IA/D	P1B-1210IA/D
890/190/100 (outlet panel)	890/190/100 (outlet panel)	890/190/100 (outlet panel)	890/190/100 (outlet panel)	1210/190/100 (outlet panel)	1210/190/100 (outlet panel)
890/290.5/32.4 (inlet panel)	890/290.5/32.4 (inlet panel)	890/290.5/32.4 (inlet panel)	890/290.5/32.4 (inlet panel)	1210/290.5/32.4 (inlet panel)	1210/290.5/32.4 (inlet panel)
938/335/220	938/335/220	938/335/220	938/335/220	1258/335/220	1258/335/220
4/5	4/5	4/5	4/5	5/6	5/6
S	S	S	S	S	S
HW-BA101ABT	HW-BA101ABT	HW-BA101ABT	HW-BA101ABT	HW-BA101ABT	HW-BA101ABT
YR-E16B	YR-E16B	YR-E16B	YR-E16B	YR-E16B	YR-E16B
YR-E17A	YR-E17A	YR-E17A	YR-E17A	YR-E17A	YR-E17A
YR-HRS01	YR-HRS01	YR-HRS01	YR-HRS01	YR-HRS01	YR-HRS01

High ESP DUCT (20/200Pa)



HW-BA116ABK



YR-E17A



HW-BA101ABT



YR-E16B



YR-HRS01

*1. HW-BA116ABK, YR-E17A and HW-BA101ABT have built-in infrared signal receiver; YR-E16B no such function

Model/Indoor unit			AD052MJERAD	AD072MJERAD	AD092MJERAD
Capacity	Cooling	HP	0.5	0.8	1.0
		kBtu/h	5.1	7.5	9.6
	Heating	kBtu/h	5.8	8.5	10.9
		kW	1.7	2.5	3.2
Electrical Parameters	Power supply	Ph/V/Hz	1/220-240/50/60	1/220-240/50/60	1/220-240/50/60
Dimensions	Net Product	mm	700/700/248	700/700/248	700/700/248
	Shipping Product	mm	932/835/280	932/835/280	932/835/280
Weight	Product Net/Shipping	kg	27/32	27/32	27/32
Fan	Static Pressure(Standard/Max)	Pa	20/200	20/200	20/200
	Air flow (H/M/L)	m ³ /h	515/440/390	545/470/390	545/470/390
Sound level	Sound pressure level(H/M/L)	dB(A)	29/27/25	30/28/25	30/28/25
	Sound power level(H/M/L)	dB(A)	41/39/37	42/40/37	42/40/37
Piping	Refrigerant liquid pipe	mm	6.35	6.35	6.35
	Refrigerant gas pipe	mm	9.52	9.52	9.52
Drain pump	O-optional, S-standard, N-not	/	S	S	S
Controller	Wired(Optional)	/	YR-E17A	YR-E17A	YR-E17A
		/	YR-E16B	YR-E16B	YR-E16B
		/	HW-BA116ABK	HW-BA116ABK	HW-BA116ABK
		/	HW-BA101ABT	HW-BA101ABT	HW-BA101ABT
	Infrared(Optional)	/	YR-HRS01	YR-HRS01	YR-HRS01



DC fan motor



Only 248mm thick



Built-in drain pump



All module can realize
50/60Hz



DUCT^T (20/200Pa)

High ESP

DUCT^T (20/200Pa)

AD122MJERAD	AD162MJERAD	AD182MJERAD	AD242MJERAD	AD282MJERAD	AD302MJERAD	AD382MJERAD	AD482MJERAD	AD542MJERAD
1.25	1.7	2.0	2.5	3.0	3.2	4.0	5.0	6.0
12.3	15.3	19.1	24.2	27.3	30.7	38.2	47.8	54.6
3.6	4.5	5.6	7.1	8	9	11.2	14	16
13.7	17	21.5	27.3	30.7	34.1	44.4	55.6	61.4
4	5	6.3	8	9	10	13	16.3	18
1/220-240/50/60	1/220-240/50/60	1/220-240/50/60	1/220-240/50/60	1/220-240/50/60	1/220-240/50/60	1/220-240/50/60	1/220-240/50/60	1/220-240/50/60
700/700/248	700/700/248	1100/700/248	1100/700/248	1100/700/248	1100/700/248	1500/700/248	1500/700/248	1500/700/248
932/835/280	932/835/280	1332/835/280	1332/835/280	1332/835/280	1332/835/280	1698/857/305	1698/857/305	1698/857/305
27/32	28.5/33.5	36.8/43.4	36.8/43.4	36.8/43.4	39.4/45.4	48.3/56.5	51.3/59.5	51.3/59.5
20/200	20/200	20/200	20/200	20/200	20/180	20/180	20/180	20/180
570/495/420	700/625/550	915/765/640	1275/1050/875	1275/1050/875	1450/1200/1000	2000/1700/1400	2150/1750/1400	2350/1950/1600
31/29/27	32/30/28	33/31/29	34/31/29	35/33/30	36/33/30	38/35/32	40/36/32	42/38/34
43/41/39	44/42/40	45/43/41	46/43/41	47/45/42	48/45/42	50/47/44	52/48/44	54/50/46
6.35	6.35	6.35	9.52	9.52	9.52	9.52	9.52	9.52
12.7	12.7	12.7	15.88	15.88	15.88	15.88	15.88	15.88
S	S	S	S	S	S	S	S	S
YR-E17A	YR-E17A	YR-E17A	YR-E17A	YR-E17A	YR-E17A	YR-E17A	YR-E17A	YR-E17A
YR-E16B	YR-E16B	YR-E16B	YR-E16B	YR-E16B	YR-E16B	YR-E16B	YR-E16B	YR-E16B
HW-BA116ABK	HW-BA116ABK	HW-BA116ABK	HW-BA116ABK	HW-BA116ABK	HW-BA116ABK	HW-BA116ABK	HW-BA116ABK	HW-BA116ABK
HW-BA101ABT	HW-BA101ABT	HW-BA101ABT	HW-BA101ABT	HW-BA101ABT	HW-BA101ABT	HW-BA101ABT	HW-BA101ABT	HW-BA101ABT
YR-HRS01	YR-HRS01	YR-HRS01	YR-HRS01	YR-HRS01	YR-HRS01	YR-HRS01	YR-HRS01	YR-HRS01

High ESP DUCT⁺ (100/250Pa)



YR-E16B



DC fan motor



Max. ESP 250Pa



Max. capacity 28kw



All module can realize
50/60Hz

Model/Indoor unit				
Capacity	Model capacity	HP		
	Cooling	kBtu/h		
		kW		
	Heating	kBtu/h		
kW				
Electrical Parameters	Power supply	Ph/V/Hz		
Dimensions (W/D/H)	Net Product	mm		
	Shipping Product	mm		
Weight	Product Net/Shipping	kg		
Fan	Static Pressure(Standard/Max)	Pa		
	Air flow (H/M/L)	m ³ /h		
Sound level	Sound pressure level(H/M/L)	dB(A)		
Piping	Refrigerant liquid pipe	mm		
	Refrigerant gas pipe	mm		
Drain Pump	O-optional ,S-standard, N-not	/		
Controller	Wired(Optional)	/		



DUCT (20/200Pa)

High ESP

DUCT (100/250Pa)

AD722MGERA	AD962MGERA
8	10
77.1	95.6
21	28
85.3	105.8
23	31
1/220-240/50/60	1/220-240/50/60
1330/895/500	1330/895/500
1590/1087/690	1590/1087/690
103/146	103/146
100/250	100/250
4200/3900/2500	5200/4390/3500
55/51/47	62/58/54
12.7	12.7
22.22	22.22
N	N
YR-E16B	YR-E16B

N High WALL



HW-BA116ABK



YR-E17A



HW-BA101ABT



YR-E16B



YR-HRS01



DC fan motor

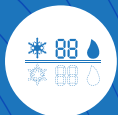

Stylish design & LED display



Built in EEV, easy to installation



Comfortable Sleep

Model/Indoor unit			AS052MNERAB AS052MNERAC	AS072MNERAB AS072MNERAC	
Capacity	Cooling	kBtu/h	5.1	7.5	
		kW	1.5	2.2	
	Heating	Btu/h	5.8	8.5	
		kW	1.7	2.5	
Electrical Parameters	Power supply	Ph/V/Hz	1/220-240/50/60	1/220-240/50/60	
	Air flow (H)	m ³ /h	500/430/370	550/480/420	
Performance	Sound pressure level(H/M/L)	dB(A)	33/31/29	35/31/29	
	Sound power level(H/M/L)	dB(A)	49/46//41	50/47/42	
	External dimensions(W/D/H)	mm	855/208/280	855/208/280	
Installation	Shipping dimensions(W/D/H)	mm	954/279/355 *1054/279/355	954/279/355 *1054/279/355	
	Net/Shipping weight	kg	9.9/12 *9.9/14.2	9.9/12 *9.9/14.2	
	Refrigerant liquid pipe	mm	6.35	6.35	
	Refrigerant gas pipe	mm	9.52	9.52	
	Controller	Wired(Optional)	/	HW-BA101ABT	HW-BA101ABT
/			YR-E16B	YR-E16B	
/			HW-BA116ABK	HW-BA116ABK	
/			YR-E17A	YR-E17A	
Infrared(Optional)		/	YR-HRS01	YR-HRS01	

*Note: Please choose AV***MN(F)ERAC series for quiet required environment.
The electronic expansion valve of AV***MN(F)ERAC series is outside.

*For AS***MN(F)ERAC



N High WALL

AS092MNERAB AS092MNERAC	AS122MNERAB AS122MNERAC	AS162MNERA AS162MNERAC	AS182MNERA AS182MNERAC	AS242MNERA AS242MNERAC	AS282MNERA AS282MNERAC	AS302MNERA AS302MNERAC
9.5	12.3	15.3	19.1	24.2	27.3	30.7
2.8	3.6	4.5	5.6	7.1	8	9
10.9	13.6	17.1	21.5	27.3	30.7	34.1
3.2	4	5	6.3	8	9	10
1/220~240/50/60	1/220~240/50/60	1/220~240/50/60	1/220~240/50/60	1/220~240/50/60	1/220~240/50/60	1/220~240/50/60
600/530/470	630/560/500	800/720/650	920/800/720	1010/920/800	1500/1400/1300	1600/1500/1400
36/31/29	37/33/29	39/36/34	40/39/35	44/40/36	48/43/40	49/44/41
52/48/44	54/51/50	56/53/51	57/54/52	58/56/54	60/57/53	61/58/54
855/208/280	855/208/280	1115/243/336	1115/243/336	1115/243/336	1316/270/365	1316/270/365
954/279/355 *1054/279/355	954/279/355 *1054/279/355	1206/342/418 *1306/342/418	1206/342/418 *1306/342/418	1206/342/418 *1306/342/418	1403/384/463 *1503/384/463	1403/384/463 *1503/384/463
9.9/12 *9.9/14.2	9.9/12 *9.9/14.2	15.8/18.9 *15.8/21.2	15.8/18.9 *15.8/21.2	15.8/18.9 *15.8/21.2	21.8/26.3 *21.8/27.2	21.8/26.3 *21.8/27.2
6.35	6.35	6.35	6.35	9.52	9.52	9.52
9.52	12.7	12.7	12.7	15.88	15.88	15.88
HW-BA101ABT	HW-BA101ABT	HW-BA101ABT	HW-BA101ABT	HW-BA101ABT	HW-BA101ABT	HW-BA101ABT
YR-E16B	YR-E16B	YR-E16B	YR-E16B	YR-E16B	YR-E16B	YR-E16B
HW-BA116ABK	HW-BA116ABK	HW-BA116ABK	HW-BA116ABK	HW-BA116ABK	HW-BA116ABK	HW-BA116ABK
YR-E17A	YR-E17A	YR-E17A	YR-E17A	YR-E17A	YR-E17A	YR-E17A
YR-HRS01	YR-HRS01	YR-HRS01	YR-HRS01	YR-HRS01	YR-HRS01	YR-HRS01



MRV INDOOR Ventilation



Fresh Air Duct



HRV



067 VENTILATION

Fresh Air Duct

HRV

Fresh Air DUCT



HW-BA116ABK



YR-E17A



HW-BA101ABT



YR-E16B

Model/Indoor unit			AD482MJERF	
Capacity	Cooling	kBtu/h	47.7	
		kW	14	
	Heating	Btu/h	30.4	
		kW	8.9	
Electrical Parameters	Power supply	Ph/V/Hz	1/220~230/50/60	
	Air flow (H)	m ³ /h	1600/1460/1070	
Performance	Sound pressure level(H/M/L)	dB(A)	48/47/42	
	Sound power level(H/M/L)	dB(A)	61/60/56	
	External dimensions(W/D/H)	mm	1500/700/248	
Installation	Shipping dimensions(W/D/H)	mm	1718/848/345	
	Net/Shipping weight	kg	43.6/50.4	
	Refrigerant liquid pipe	mm	9.52	
	Refrigerant gas pipe	mm	15.88	
	Static Pressure(Standard/Max.)	Pa	100/200	
	Controller	Wired (Optional)	/	YR-E16A
/			YR-E16B	
/			HW-BA116ABK	
/			YR-E17A	

100~
250Pa

Variable static pressure
100~250Pa setting



Install with other indoor
units together, and
introduce the outdoor
fresh air into indoor



DC fan motor

50/60Hz

All module can realize
50/60Hz



Fresh Air DUCT

AD722MTERF	AD962MTERF
77.1	95.5
22.6	28
51.8	60.8
15.2	17.8
1/220-230/50/60	1/220-230/50/60
4000/3500/3000	4500/4000/3600
50/47/44	51/48/45
68/65/60	68/66/62
1512/856/502	1512/856/502
1558/896/612	1558/896/612
102/116	102/116
12.7	12.7
22.22	22.22
100/250	100/250
YR-E16A	YR-E16A
YR-E16B	YR-E16B
HW-BA116ABK	HW-BA116ABK
YR-E17A	YR-E17A



W9301

Be controlled with other indoor units together

Efficient heat recovery air processing

Heat recovery media element

Max. air flow 1000m³/h

Model/Indoor unit			ERV0150ANW	
Electrical	Power supply	Ph/V/Hz	1/220-240/50/60	
	Rated power input	W	135	
	Rated current	A	0.65	
Enthalpy exchange effectiveness	Cooling condition		58%	
	Heating condition		65%	
Performance	Air flow (H/M/L)	m ³ /h	150/110/70	
	Sound pressure level (H/M/L)	dB(A)	38/35/30	
	Sound power level (H/L)	dB(A)	48/45/40	
Installation	External dimensions(W/D/H)	mm	750/530/240	
	Shipping dimensions(W/D/H)	mm	955/575/305	
	Net weight/Shipping weight	kg	26/28	
	Static Pressure	Pa	80	
Controller	Wired (Standard)	/	W9301	



ERV0260ANW	ERV0500ANW	ERV0800ANW	ERV1000ANW
1/220-240/50/60	1/220-240/50/60	1/220-240/50/60	1/220-240/50/60
165	280	360	420
0.79	1.34	1.72	2.01
57%	61%	68%	61%
65%	68%	72%	65%
250/200/160	500/430/375	800/680/600	1000/810/730
40/38/35	45/42/40	48/46/43	50/48/45
50/48/45	55/52/50	58/58/53	60/58/55
750/530/270	1000/710/270	1200/940/324	1250/935/350
955/575/335	1205/755/335	1405/985/389	1455/980/415
30/32	40/42	55/59	56/60
80	100	100	100
W9301	W9301	W9301	W9301

Dimensions

1-Way Cassette

AB052MAERA AB072MAERA AB092MAERA AB122MAERA

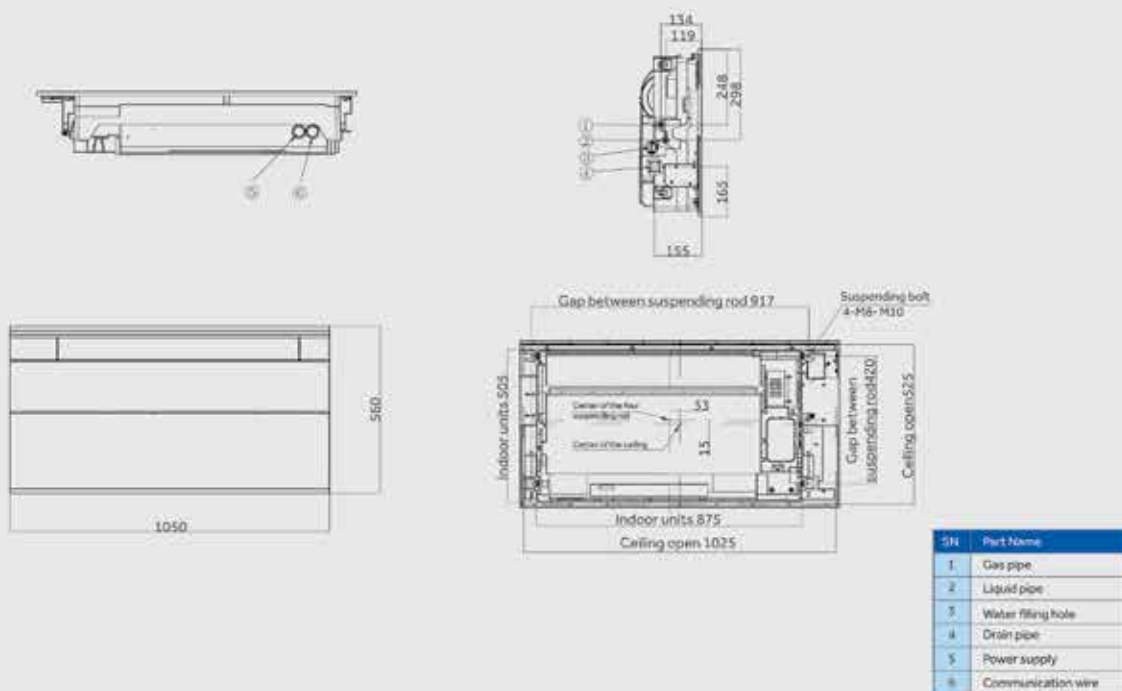

Compact Cassette

AB052MCERA(M) AB072MCERA(M) AB092MCERA(M)
AB122MCERA(M) AB162MCERA(M) AB182MCERA(M)

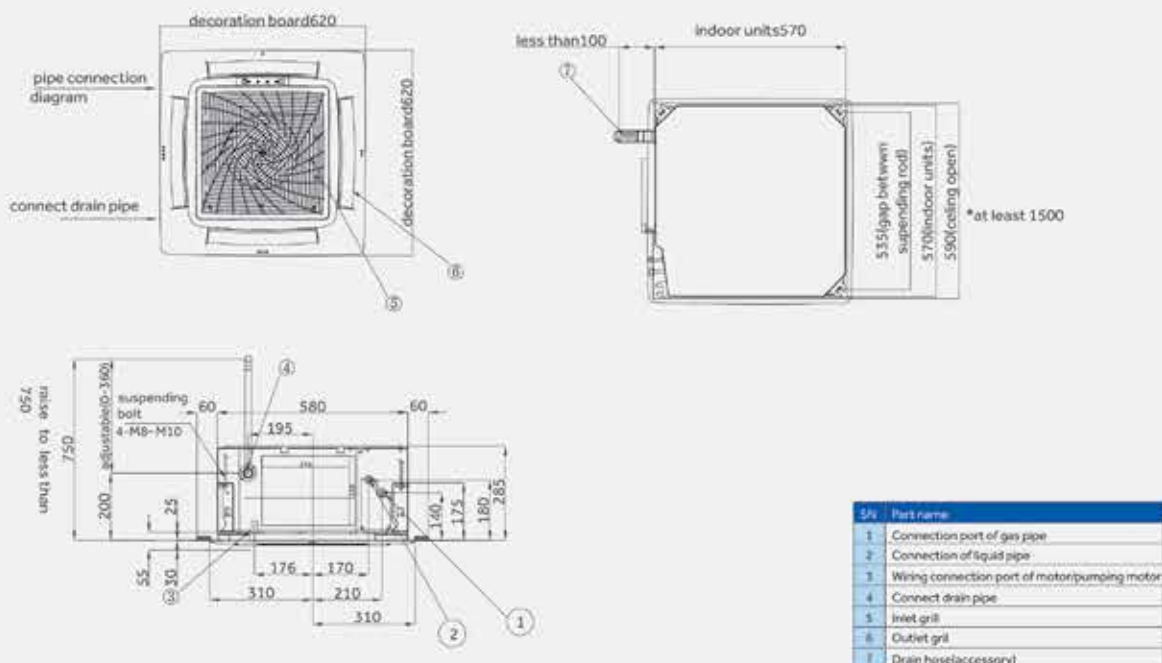

Round Way Cassette

AB072MRERA AB092MRERA AB122MRERA AB162MRERA AB162MRERA AB242MRERA
 AB282MRERA AB302MRERA AB302MRERA AB482MRERA AB602MRERA

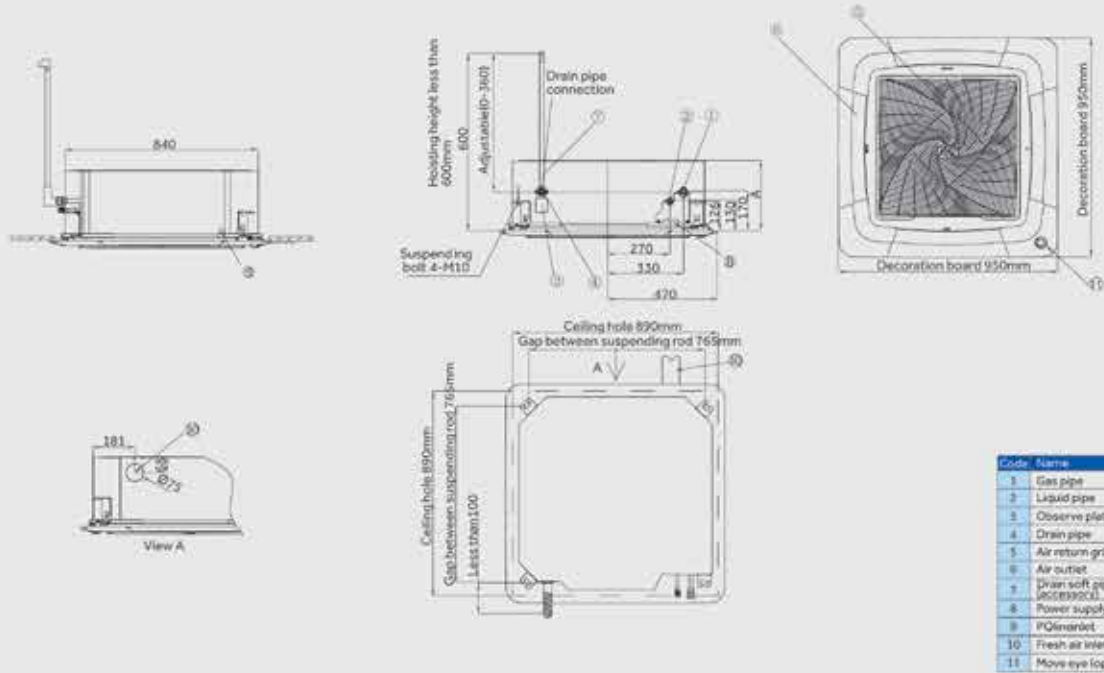

Slim Duct (0/15/30Pa) Slim Duct (0/15/30Pa) Slim Duct (0/30Pa)

AD052MSERA(H) AD072MSERA(H) AD092MSERA(H) AD122MSERA(H) AD162MSERA(H)
 AD052MSERA(D) AD072MSERA(D) AD092MSERA(D) AD122MSERA(D) AD162MSERA(D)
 AD052MSERA AD072MSERA AD092MSERA AD122MSERA AD162MSERA

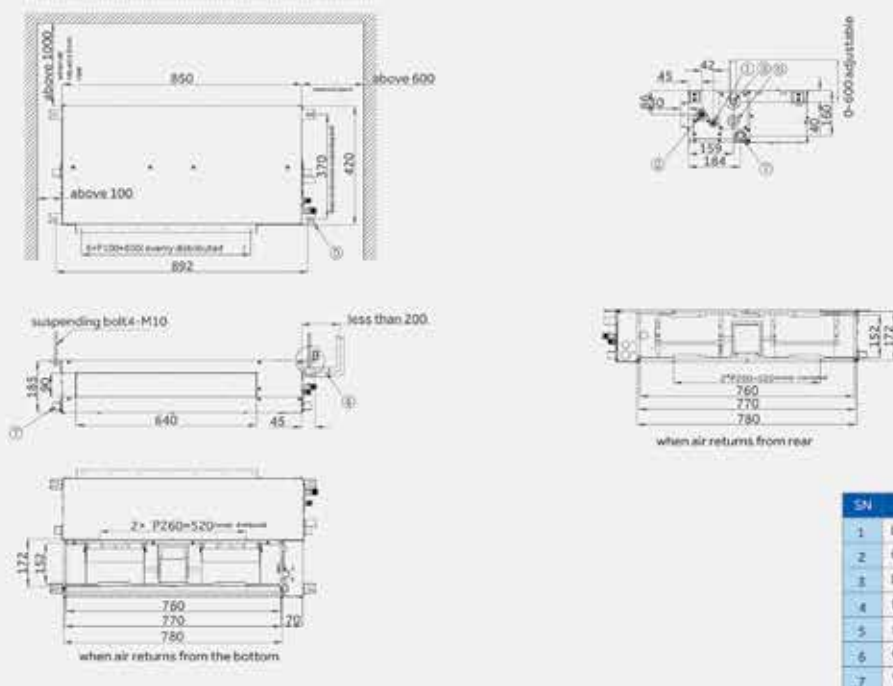

Dimensions

Slim Duct_(10/15/30Pa)
Slim Duct_(10/15/30Pa)
Slim Duct_(10/30Pa)

AD182MSERA(H) AD242MSERA(H)
AD182MSERA(D) AD242MSERA(D)
AD182MSERA AD242MSERA

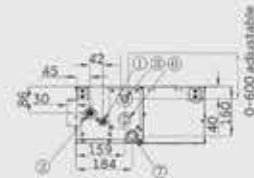
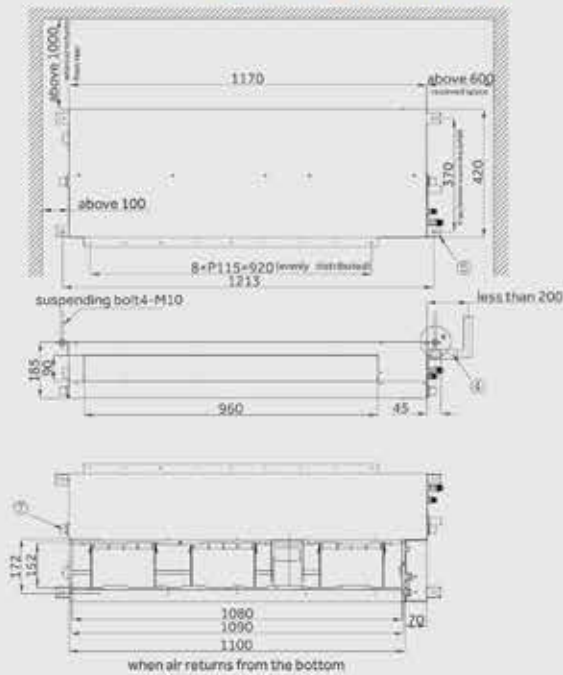

when air returns from rear

SN	Part Name
1	liquid pipe connection
2	gas pipe connection
3	drain hose with pump
4	drain hose(accessory)
5	suspending point
6	checking hole
7	water drainage outlet

High ESP Duct_(20/200Pa)
Medium ESP Duct_(50/100Pa)
High ESP Duct_(20/200Pa)

AD052MJERA(H) AD072MJERA(H) AD092MJERA(H) AD122MJERA(H) AD162MJERA(H)
AD052MJERAB AD072MJERAB AD092MJERAB AD122MJERAB AD162MJERAB
AD52MJERAD AD72MJERAD AD92MJERAD AD122MJERAD AD162MJERAD

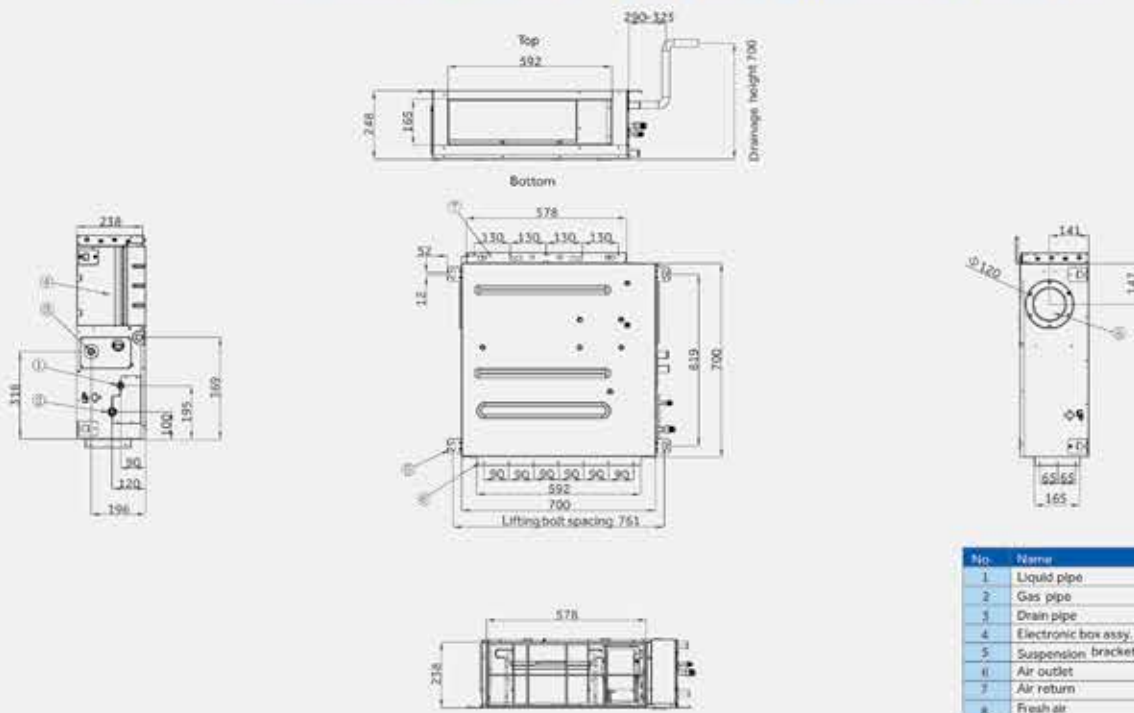

No.	Name
1	Liquid pipe
2	Gas pipe
3	Drain pipe
4	Electronic box assy.
5	Suspension bracket
6	Air outlet
7	Air return
8	Fresh air

High ESP Duct(20/200Pa)
 Medium ESP Duct(50/100Pa)
 High ESP Duct(20/200Pa)

AD182MJERA(H) AD242MJERA(H) AD282MJERA(H) AD302MJERA(H)
 AD182MJERAB AD242MJERAB AD282MJERAB AD302MJERA
 AD182MJERAD AD242MJERAD AD282MJERAD AD302MJERAD

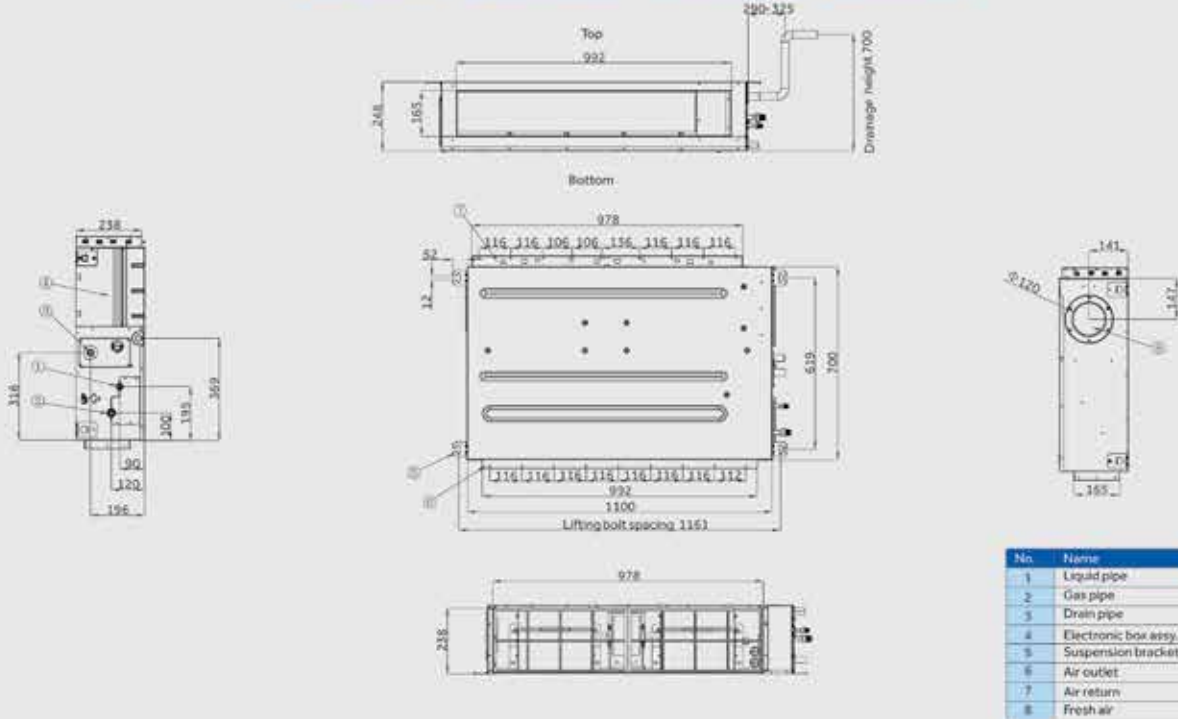

No.	Name
1	Liquid pipe
2	Gas pipe
3	Drain pipe
4	Electronic box assy.
5	Suspension bracket
6	Air outlet
7	Air return
8	Fresh air

High ESP Duct(20/200Pa)
 Medium ESP Duct(50/100Pa)
 High ESP Duct(20/200Pa)

AD382MJERA(H) AD482MJERA(H) AD542MJERA(H)
 AD382MJERA AD482MJERA AD542MJERA
 AD382MJERAD AD482MJERAD AD542MJERAD

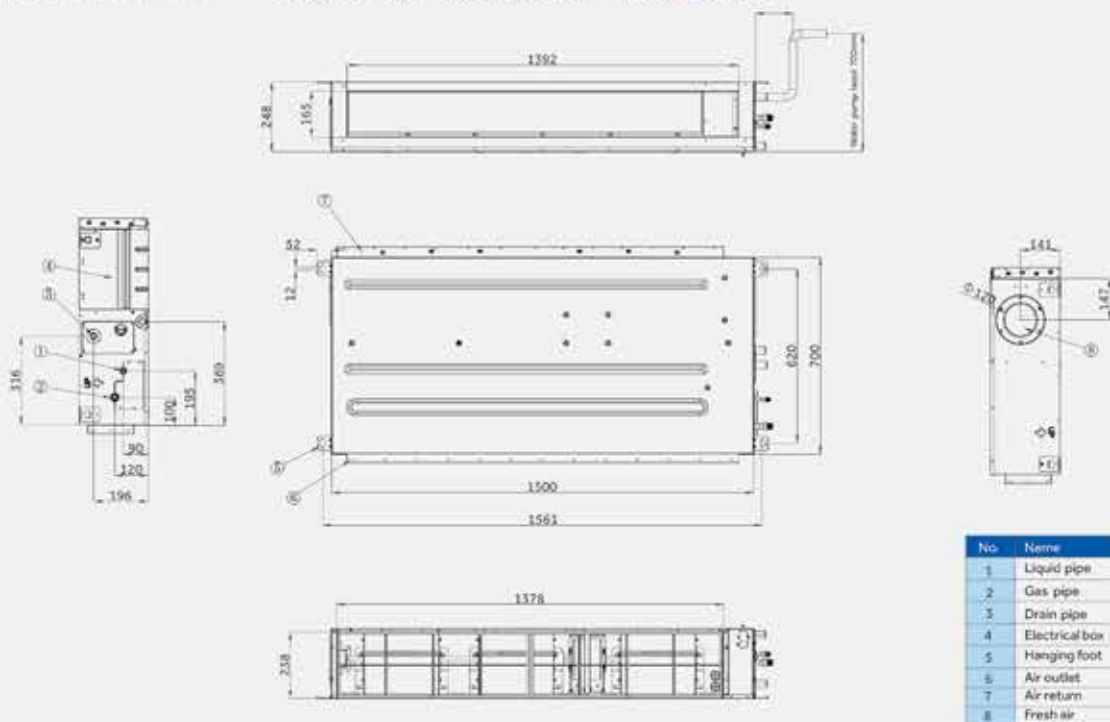

No.	Name
1	Liquid pipe
2	Gas pipe
3	Drain pipe
4	Electrical box
5	Hanging foot
6	Air outlet
7	Air return
8	Fresh air

Dimensions

High ESP Duct (100/250Pa)

AD722MGERA AD962MGERA

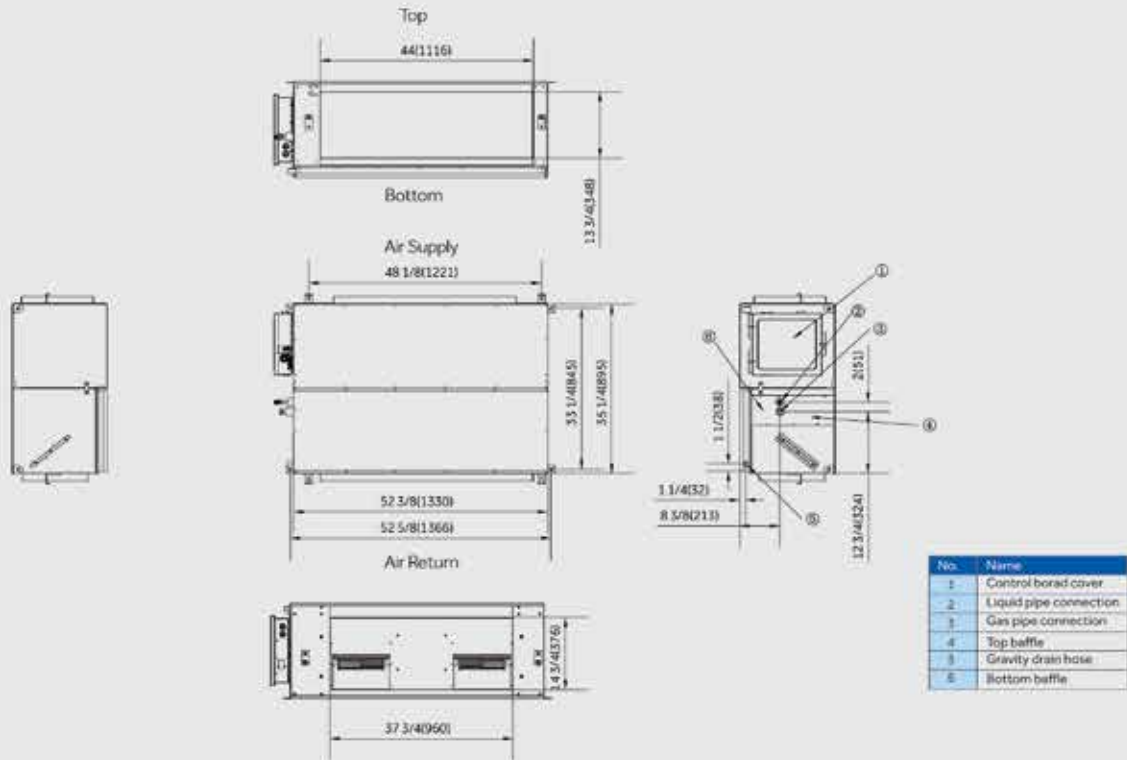

N High Wall

AS052MNERAB AS072MNERAB AS092MNERAB AS122MNERAB
AS052MFERAB AS072MFERAB AS092MFERAB AS122MFERAB

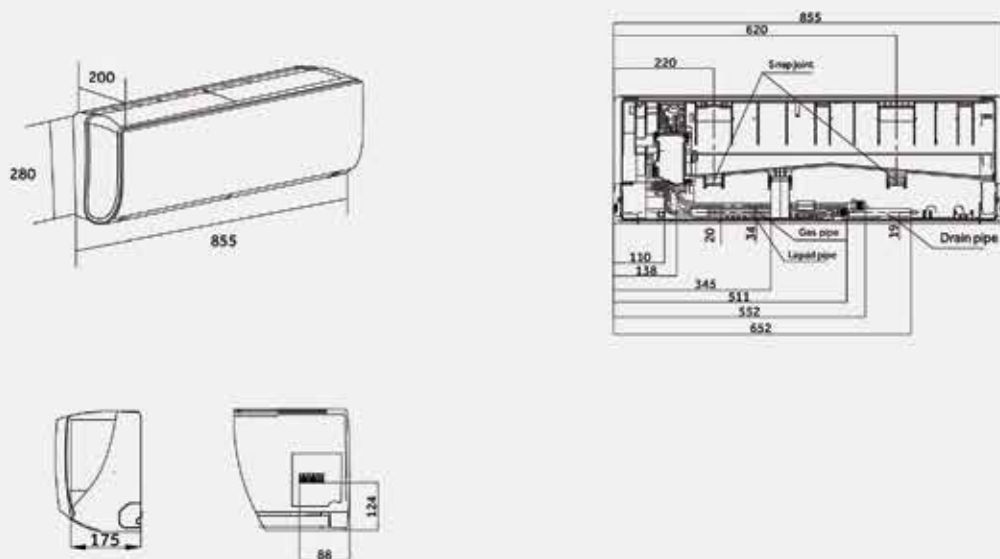

N High Wall

AS162MNERA AS182MNERA AS242MNERA
AS162MFERA AS182MFERA AS242MFERA

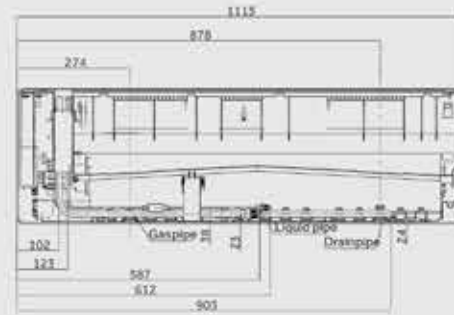
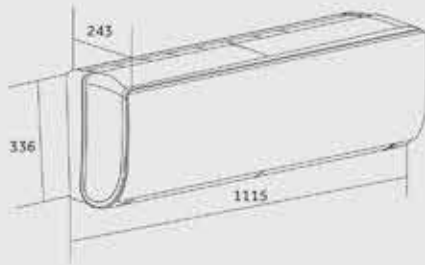

N High Wall

AS282MNERA AS302MNERA

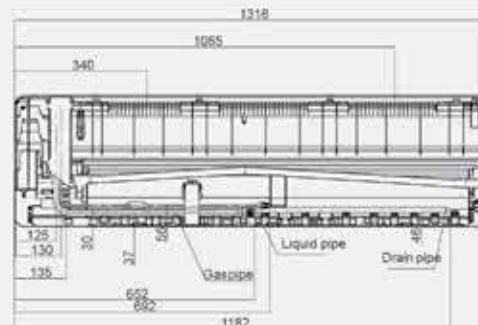
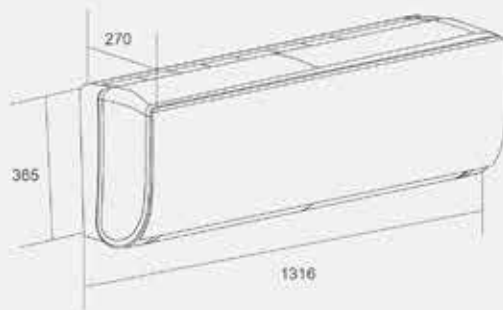

Dimensions

Fresh Air Duct

AD482MJERF

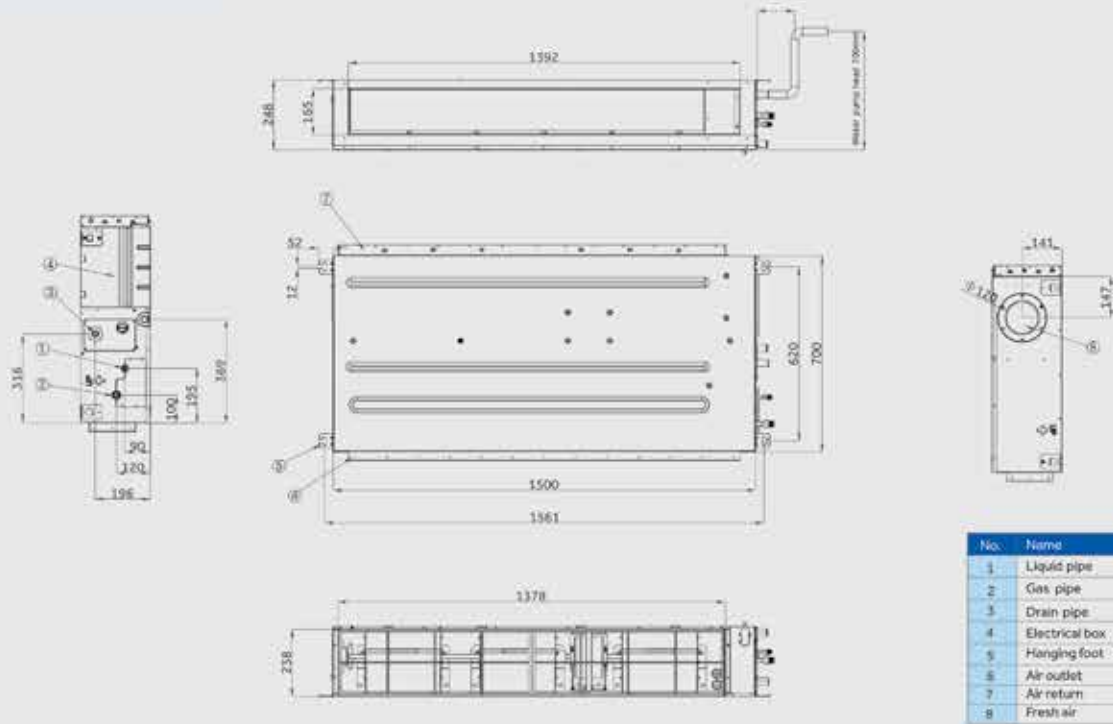

Fresh Air Duct

AD722MTERF AD962MTERF

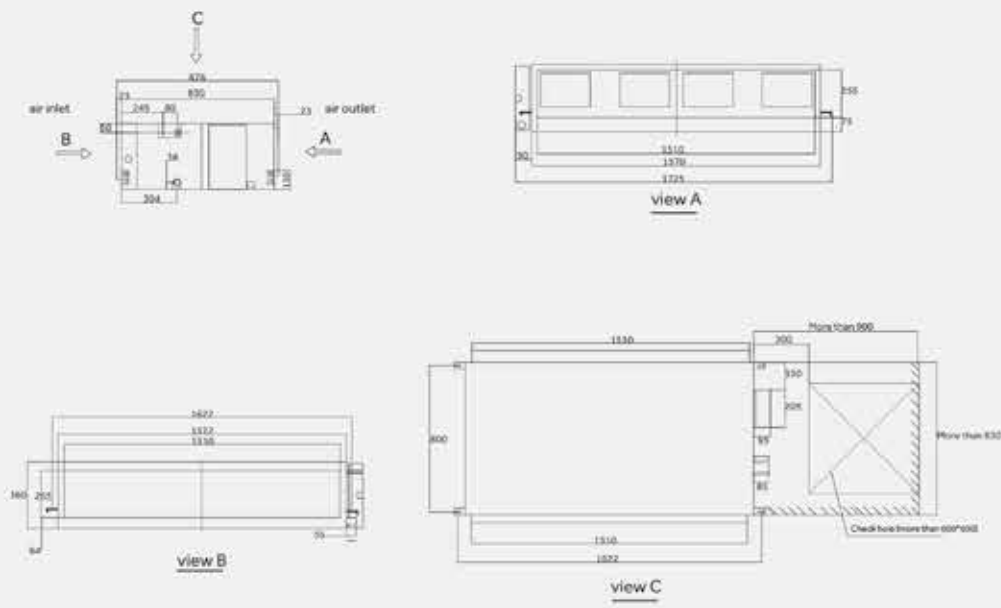

HRV

ERV0150ANW ERV0260ANW ERV0500ANW ERV0800ANW ERV1000ANW

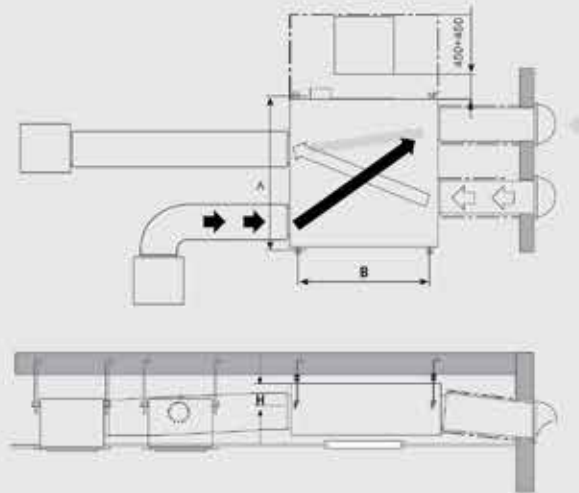

Model	A	B	H
ERV0150ANW	530	750	240
ERV0260ANW	530	750	270
ERV0500ANW	690	1000	256
ERV0800ANW	920	1200	324
ERV1000ANW	915	1250	350

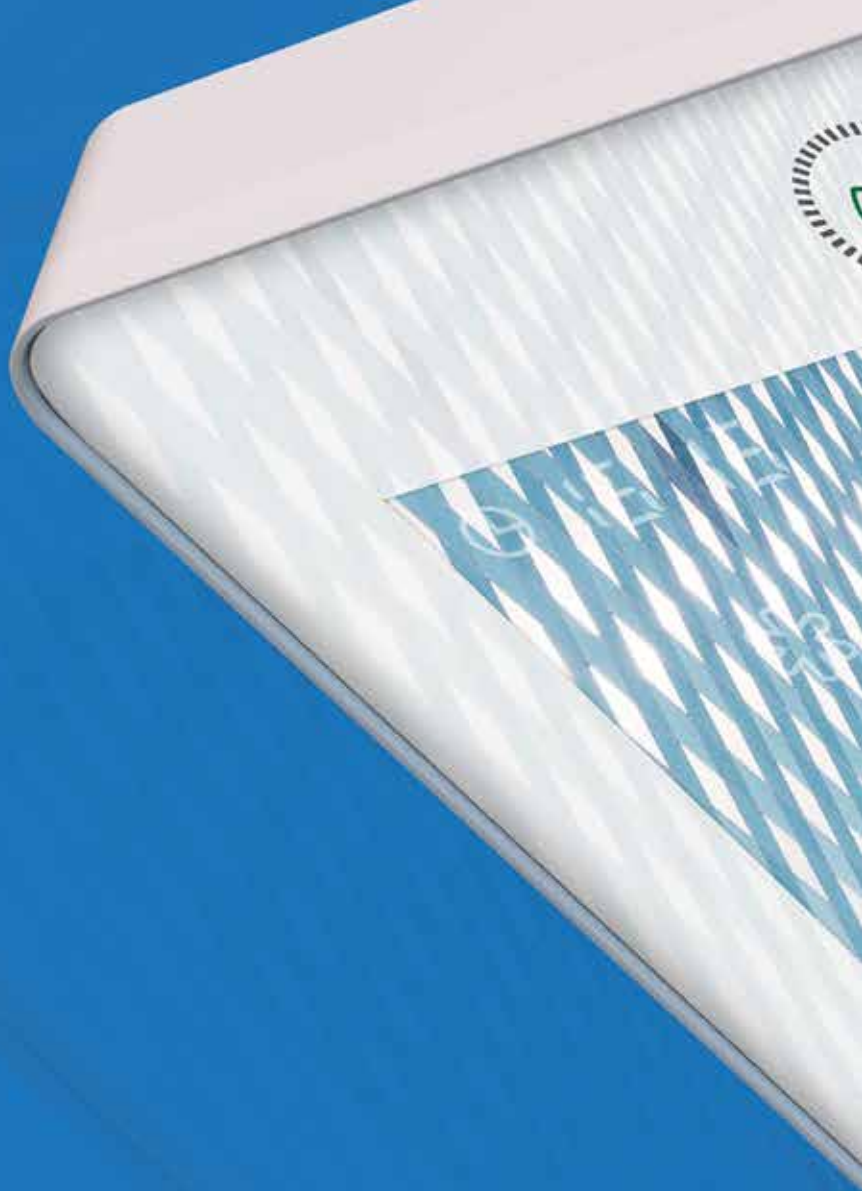

CONTROL SYSTEM



Individual Controller



Centralized Controller

BMS

BMS



Multi Tenant Solution



Service Tool



Controllers Match Table for MRV Indoor Units



Accessories



081 Individual Controller

083 Centralized Controller

087 BMS Solution

093 Multi Tenant Solution

094 Service Tool



Individual Controller

The individual control system has a variety of wired and wireless controllers which enable you easy and intelligent control of your air conditioners. You can choose the one which best suits for your air conditioning management.

INDIVIDUAL CONTROLLER

YR-HQS01

- On/Off, Operation Mode, Fan speed, Temperature setting, Swing
- Turbo and Quiet
- Individual louver control for Round Flow 4-way cassette and mini 4-way cassette
- Clock & Timer
- Health function
- Self-Clean
- Backlight
- Convenient to operate most functions through one button



YR-HRS01

- On/Off, Operation Mode, Fan speed, Temperature setting, Swing
- Turbo and quiet
- Individual louver control for Round Flow 4-way cassette and mini 4-way cassette
- Self-Clean
- Timer
- Health function
- Backlight





INDIVIDUAL CONTROLLER

YR-E17A

- On/Off, Mode, Fan speed, Temperature setting, Swing
- Individual & Group control (Max.16 indoor units)
- Simple and Smart design, 86*86*13.05mm
- Touch button with back light
- Timer / Clock
- Individual flap control for round way cassette and compact cassette
- Built-in infrared signal receiver for duct units
- Self-cleaning function
- Built-in humidity sensor and humidity display



HW-BA116ABK

- Basic function: on/off, mode, fan speed, temperature
- Individual & group control (max. 16 indoor units)
- Simple and smart design, 86*86*14.80mm
- Could receive wireless controller signal



HW-BA101ABT

- Individual & group control (max. 16 indoor units controllable)
- Compact design 86*86mm
- Touch screen
- Black and tempered glass body with highlight LED icon display
- Basic function: on/off, mode, swing, dry, auto
- Built-in infrared signal receiver for infrared remote control
- Built-in buzzer

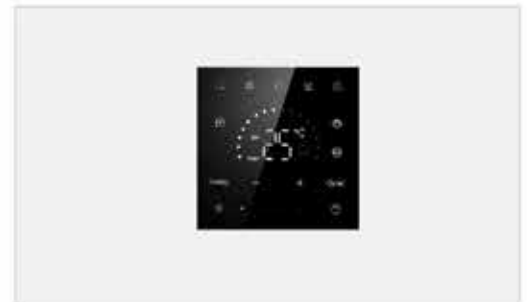

YR-E16B

- Colorful screen
- On/off, mode, fan speed, temperature setting, swing
- Individual & group control (max 16 indoor units)
- Fahrenheit/ celsius selectable; sensitivity $\pm 0.5^{\circ}\text{C}$ ($\pm 1^{\circ}\text{F}$)
- Weekly timer
- Individual louver control for MINI 4-way cassette and Round Flow 4-way cassette
- Static pressure setting



RE-02

- Infrared signal receiver
- Realize the remote control of duct type indoor unit
- Model selection depends on the duct indoor unit





Centralized Controller

The centralized control system offers you a smart and convenient experience while managing your air conditioner individually or by groups or by zones, a variety of controllers can be used to perfect your air conditioning management.



CENTRALIZED CONTROLLER

HC-SA164DBT

- Individual control; central control (max. 64 indoor units)
- 5-inch TFT LCD touch screen with back light.
- Weekly timer
- Indoor units' information editable
- Historical error
- MRV 5 system and upgraded MRV SII(8/10/12HP) outdoor units can connect directly
- Other MRV system requires HA-MA164AD



CENTRALIZED CONTROLLER

Monitoring up to 64 indoor unit could control HRV and monitoring the state of all IDU display Fault IDU number



Set schedule for unit, group, all time control could be add, change, delete, unit control, group control, all ON/OFF



Turn ON/OFF the DST DST schedule time setting DST compensation setting



Display the detailed information check the name, number, temperature, running time and fault code



Interface display mode choice: list or icon All on, all off, control all, control select



Setting password according to user demand



HC-SA164DBT System

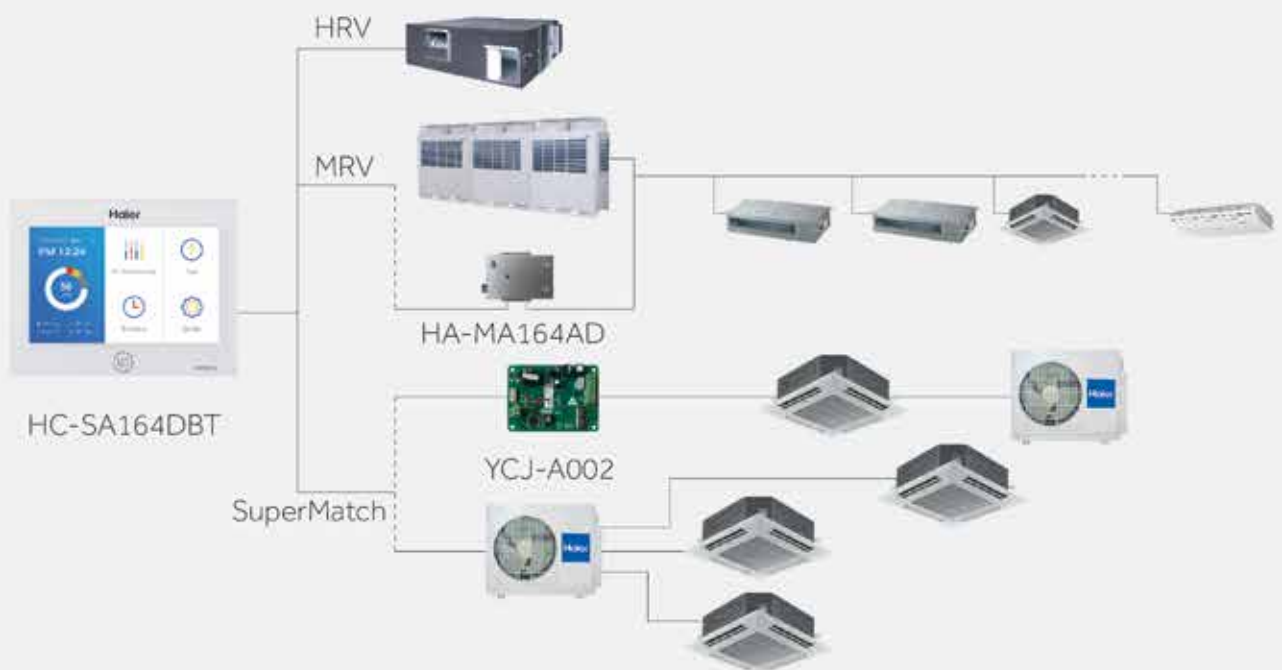



CENTRALIZED CONTROLLER

YCZ-A004

- Individual control, group control & central control (Max. 256 indoor units)
- 7-inch TFT LCD touch screen with back light
- Weekly timer
- Indoor units' information editable
- Error display
- Other MRV system requires HA-MA164AD



YCZ-A004 System

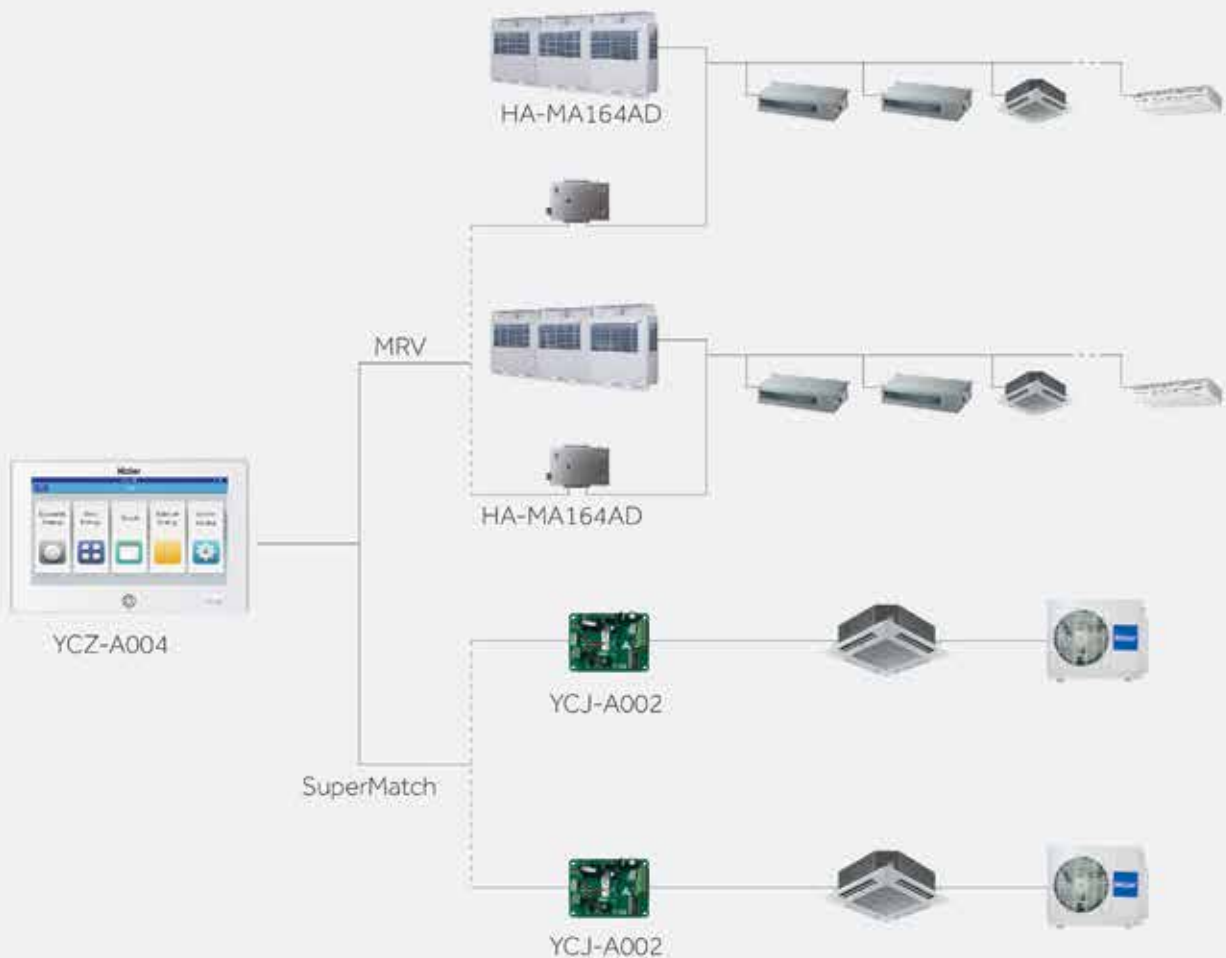



CENTRALIZED CONTROLLER

HC-LA1CDBT

- 12.5-inch TFT LCD touch screen
- Max. 800 MRV indoor units and Max. 128 LCAC IDUs connectable for one controller totally 928 IDUs connectable
- Floor plan layout view
- Web Access and Email Alarm
- Weekly Schedule and Special day setting
- Integrate 3rd party devices like fire alarm, lighting with Haier indoor units
- All MRV system requires the new gateway HA-MA1ADB(one system requires one gateway)
- LCAC products requires PCB adapter YCJ-A002(One IDU requires one YCJ-A002)
- Total electricity consumption display
- Data curve
- Electricity consumption distribution for Tenant billing
- Multi Language



NEW

HC-LA1CDBT System

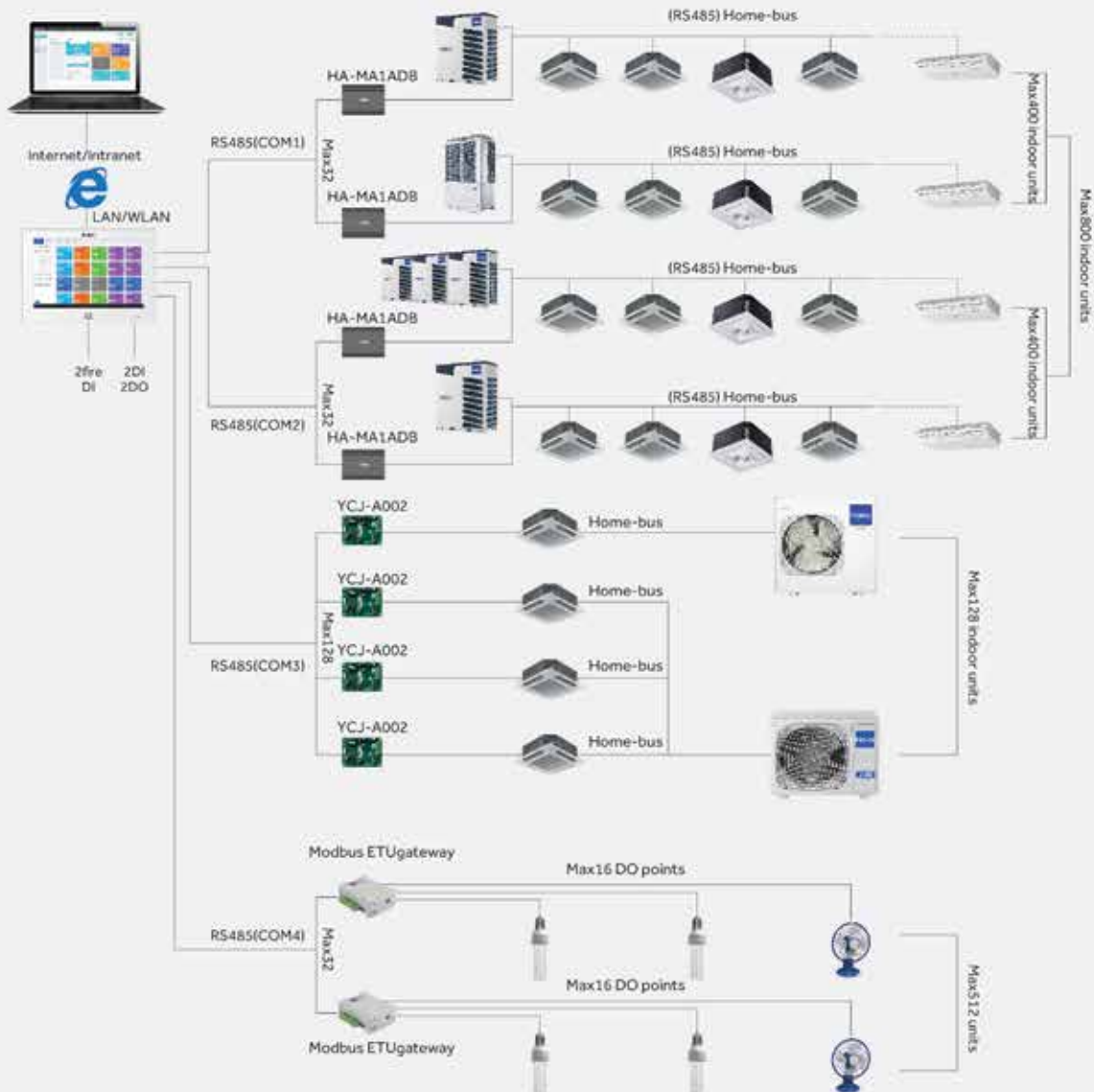

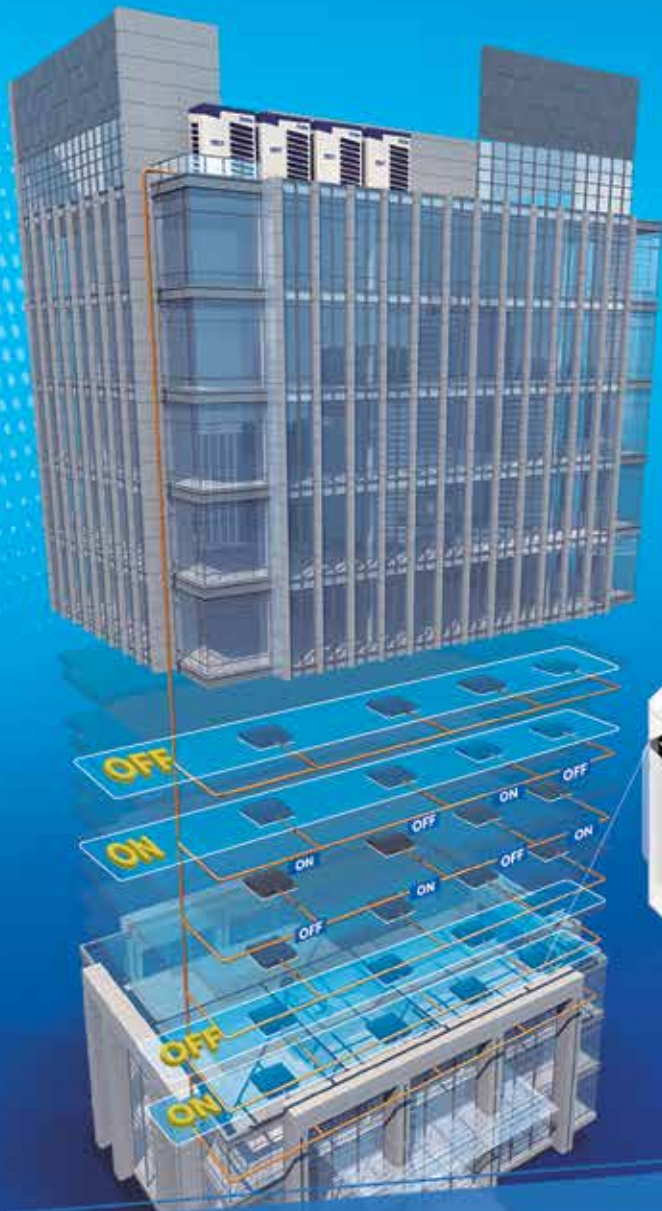

BMS Solution

The building management modules could perfectly integrate air conditioners into the building management system, providing an excellent solution for large commercial areas

Haier BMS monitor system is used to meet the demands of remote monitoring and controlling the AC systems, 3rd party BMS or BAS interface and electricity distribution management i.g the tenant billing.

BMS BMS MONITOR

HCM-01A

- Local control version: convert USB to RS-485
- Max 400 indoor units can be controlled
- Modbus rtu interface
- Brand new interface design
- Win 7 32bits/64bits, Win 8 Pro, Win 10 Pro
- Max 32 systems connectable
- MRV 5system and upgraded MRV SII(8/10/12HP) outdoor units can directly connect with HCM-01A
- Other MRV system outdoor units require HA-MA164AD
- Electricity charge report (must use IGU02)



HCM-01A System

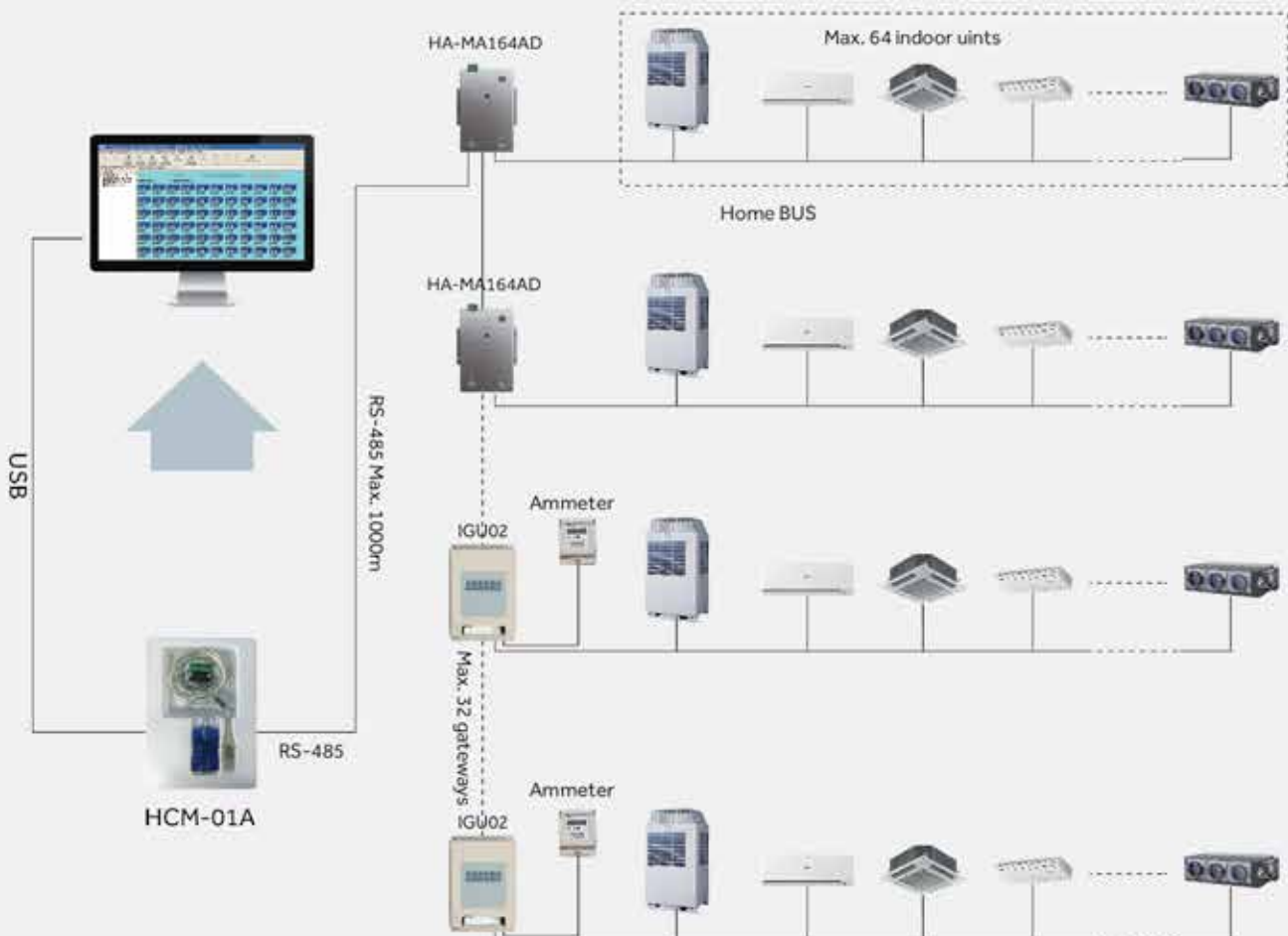

*Each outdoor system requires one HA-MA164AD, For power consumption function, users should connect IGU02 and Ammeter.

HCM-03A

- Remote monitoring version; third party interface: BACnet ip/ Modbus ip
- Max 1500 indoor units can be controlled
- Max. 4 groups, each group can connect 20 systems
- MRV 5 system and upgraded MRV SII(8/10/12HP) outdoor units can directly connect with HCM-03A
- Other MRV system outdoor units require HA-MA164AD
- Operation status setting & monitoring.
- Schedule setting
- Multi user management, with different authorized levels
- Operation and error history log
- Electricity charge report (must use IGU02)



HCM-03A System

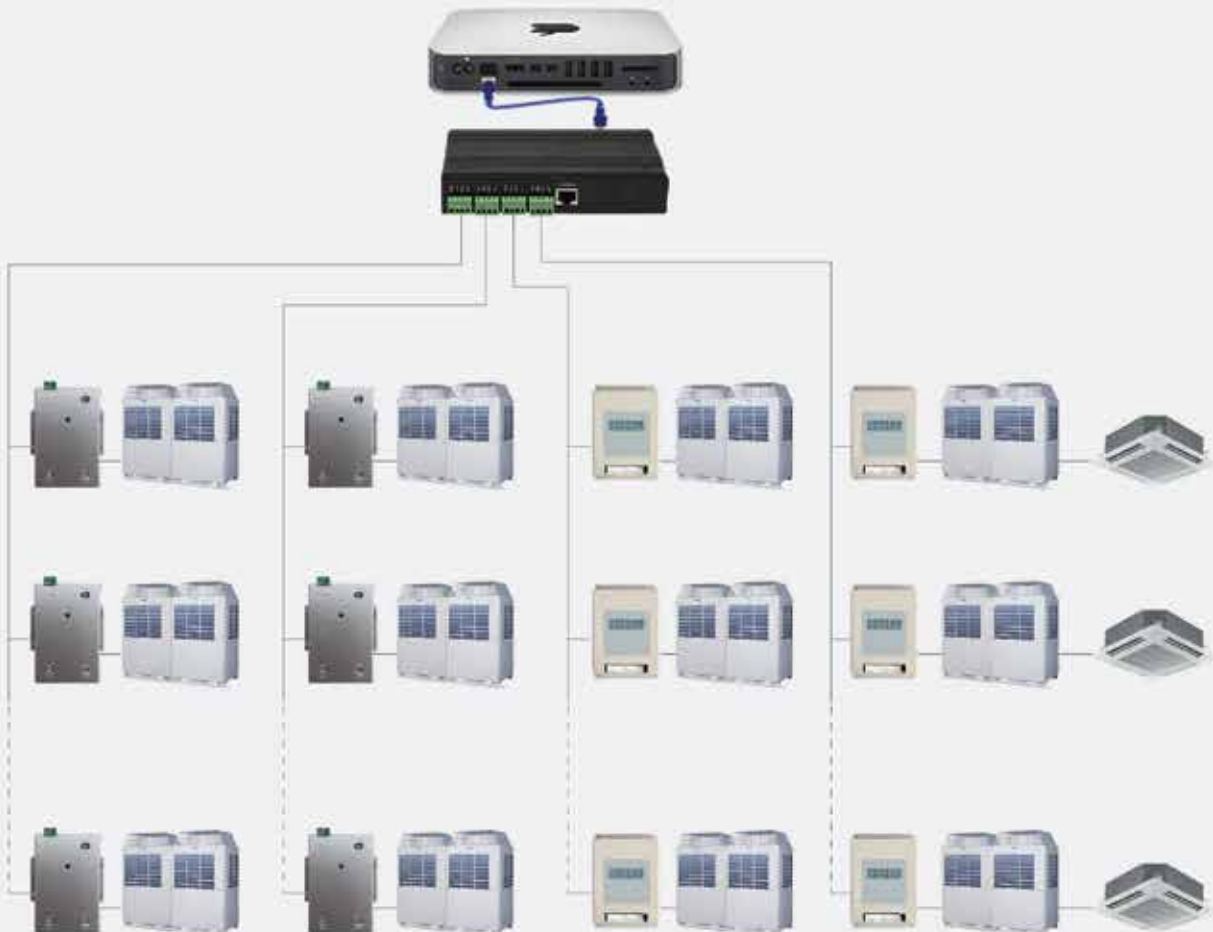

BMS BMS MONITOR

HCM-05

- Remote monitoring version
- Third party interface BACnet ip
- Max. 250 indoor units can be controlled for HCM-05; and 500 indoor units for HCM-05A
- Max. 32 systems for HCM-05. Each system requires one IGU02/HA-MA164AD
- Max. 64 systems for HCM-05A. Each system requires one IGU02/HA-MA164AD
- Operation status setting & monitoring
- Schedule setting
- Multi user management with different authorized levels
- Electricity charge report (must use IGU02)
- Operation and error history log
- Cooperated technology with honeywell



HCM-06 System

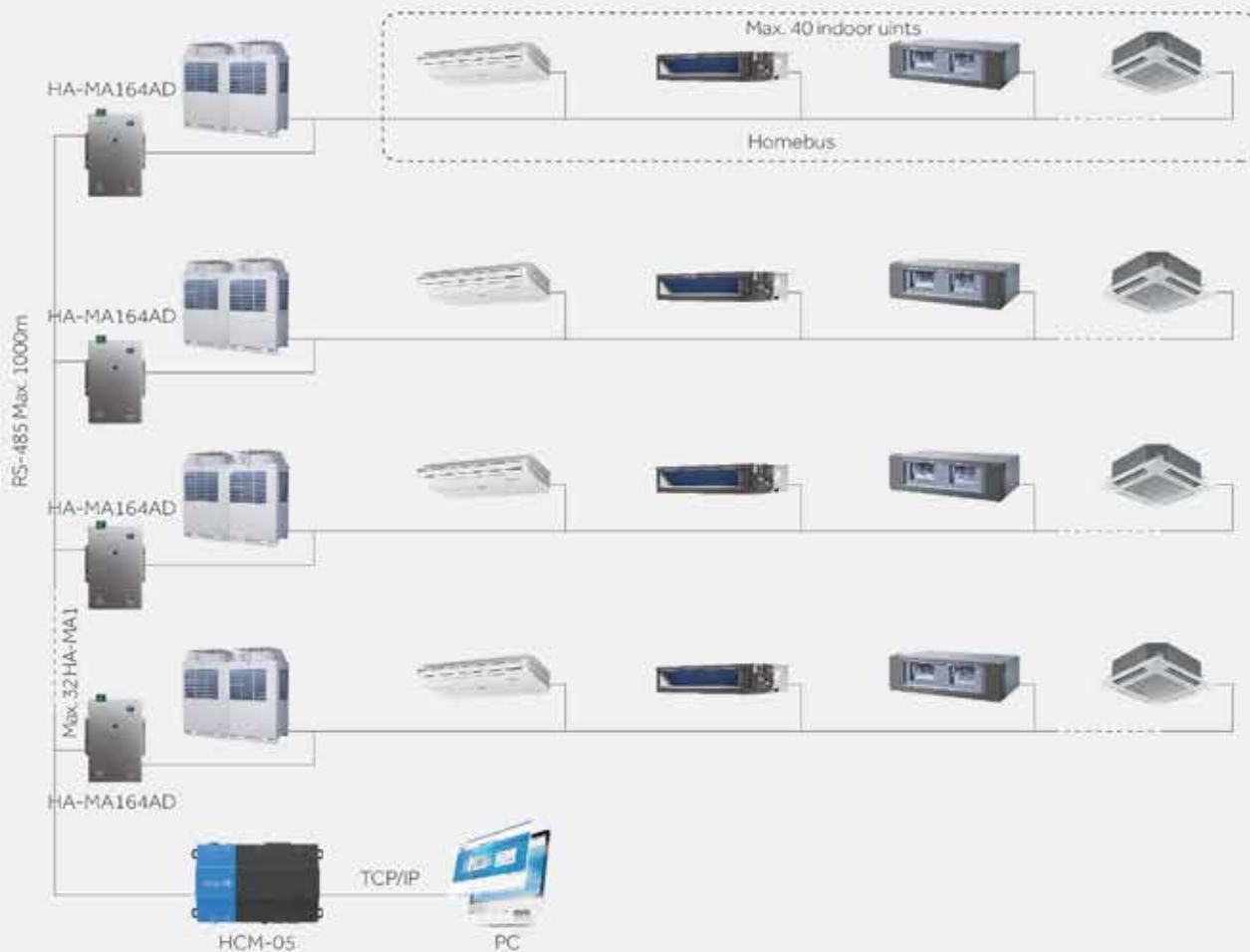



BMS interface

The adapters offer you an easy and convenient way to integrate air conditioners into various building management system; perfect for large commercial projects.

Haier BMS interface devices are used to connect the 3rd party BMS or BAS system, including the Modbus interface, BACnet interface and Lonworks interface etc.

BMS BMS INTERFACE

HA-MA164AD

- Protocol adapter, convert homebus to RS-485
- Gateway modbus rtu
- Max. 64 indoor units can be connected with one HA-MA164AD
- MRV 5 system and upgraded MRV SII(8/10/12HP) outdoor units can directly connect with central controller HC-SA164AD and YCZ-A004 or BMS monitor: HCM-01A and HCM-03A
- Other MRV system outdoor units require HA-MA164AD



HA-MA1ADB

- Interface Modbus
- Match with 12.5-inch webserver central controller HC-LA1CDBT
- Max. 128 indoor units connectable
- Digital tube display indoor quantity, gateway address, time and date
- Electricity data collection, calculation, distribution and storage



IGU02

- Protocol adapter, convert homebus to modbus
- Electricity data collection, calculation, allocation and storage
- Match with BMS (HCM-01A,03A,05,05A) each system requires one IGU02
- Max. 40 indoor units can be connected with one IGU02



IGU07

- Protocol adapter, convert modbus rtu to lonworks
- Each system requires one IGU07+ HA-MA164AD
- Max. 32 indoor units can be connected in one system
- External 24V DC power supply is needed



LonWorks System

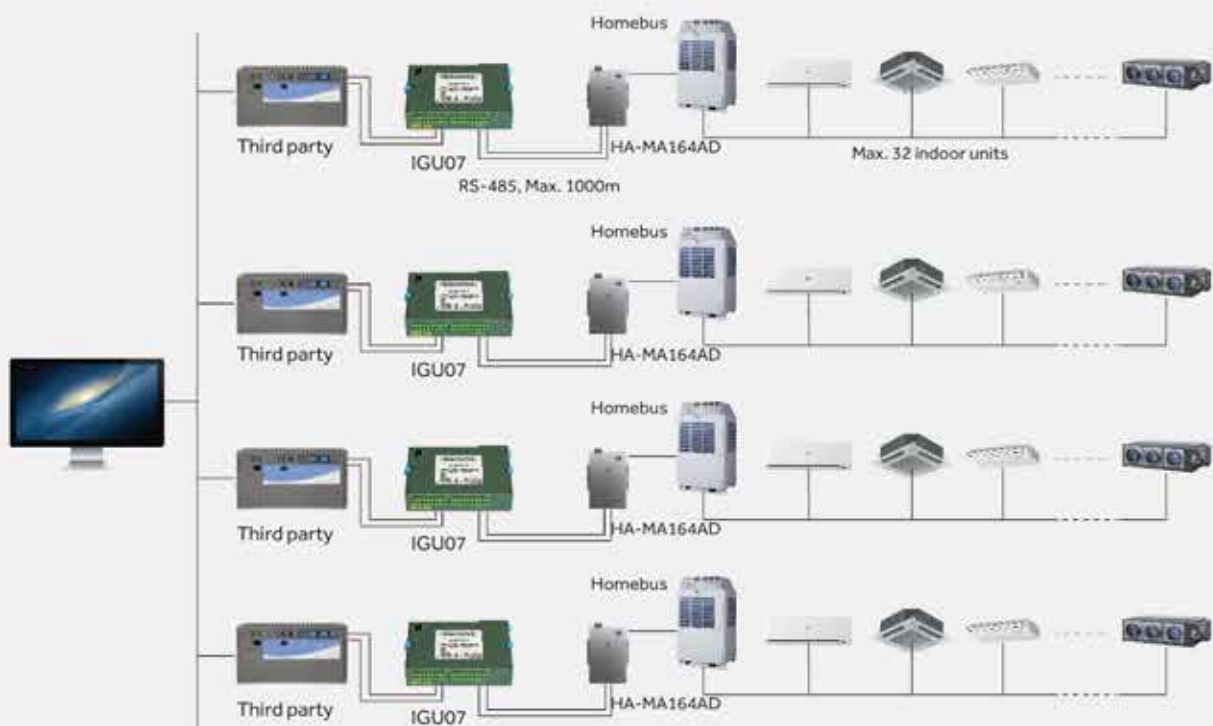

BMS BMS INTERFACE

HCM-04

- BACnet gateway, convert modbus rtu to BACnet ip
- Max 128 indoor units/ 4 systems can be controlled Max 32 indoor units for one system
- MRV 5 and upgraded MRV SII (8/10/12HP) can connect directly with HCM-04
- Other MRV systems require IGU02 or HA-MA164AD
- BTL certificate



HA-AC-KNX-8 / HA-AC-KNX-16 / HA-AC-KNX-64

- KNX gateway
- Convert modbus to KNX
- Max 8/ 16/ 64 indoor units can be connected in one system
- MRV 5 and upgraded MRV SII (8/10/12HP) can connect directly
- Other MRV systems require HA-MA164AD
- *For the KNX gateway purchase, please contact the KNX manufacture Intesis directly



👥 MULTI TENANT SOLUTION

MTC-001

Application Scenario:

- a. The multi tenant site using separate circuit breaker for each indoor unit.
- b. The hotel room using key-tag system which cuts off the power of indoor unit directly
- When it is detected that any connected indoor unit is forcibly cut off, the MTC-001 provides DC power to the indoor PCB to ensure that the indoor unit maintains standby mode: the EEV is turned off and the control signal is blocked to prevent the system from alarming
- Note: If there is power or communication failure in the indoor computer board, MTC-001 cannot be prevented and detected

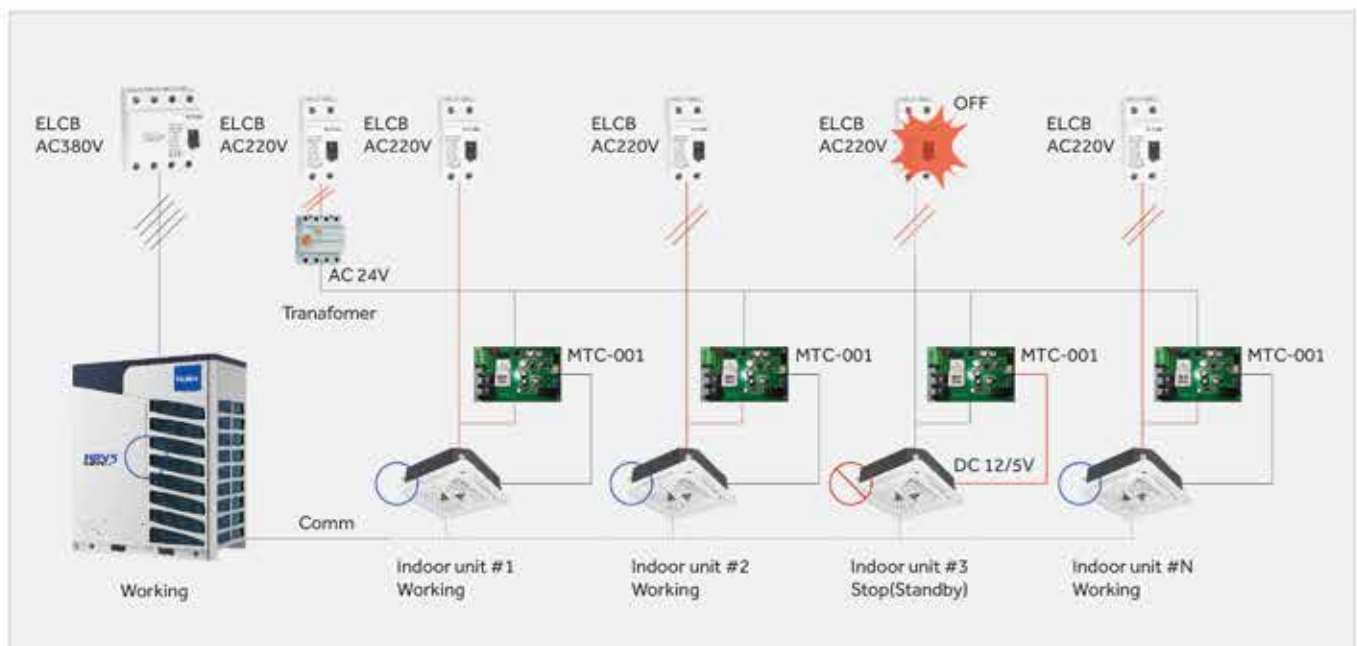

Address setting and checking tool YR-NS

- On/Off, Mode, Fan speed, Temperature setting, Swing
- IDU address checking
- IDU address setting

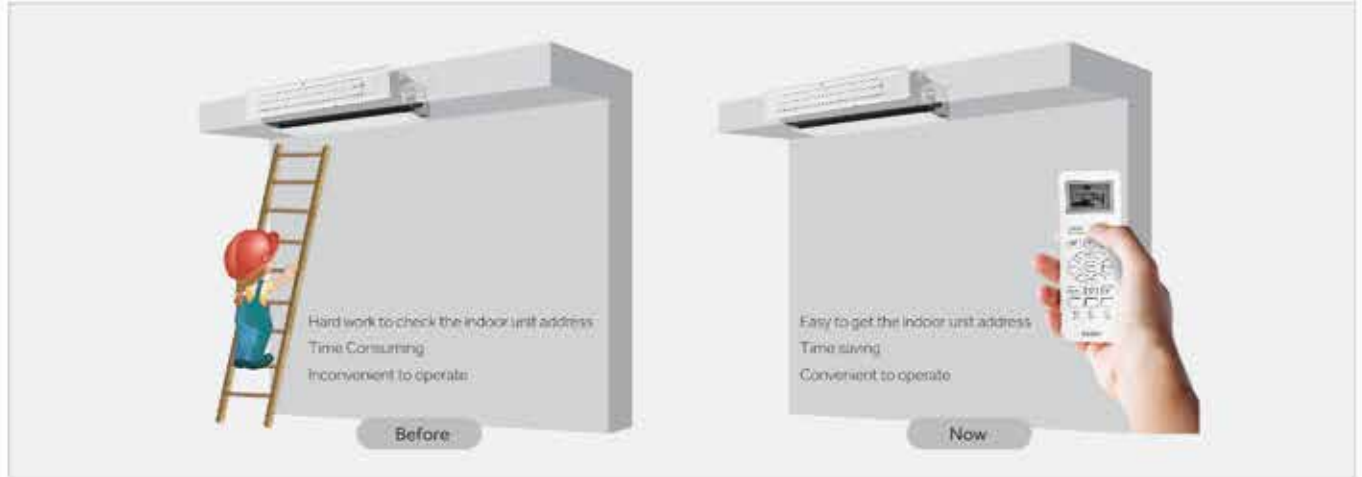

Haier HACS Selection Software -easy to Design and Customization

Haier HACS Selection Software supports PC & App, which means the reports and information on the phone and computer are synchronous.

With the Haier MRV Selection software, engineers and consultants can easily design, layout and prepare a full MRV system for quotation in a few steps. It selects the right models to meet your building load requirements and calculates the piping schematic automatically or manually, as well as the wiring. It's possible to import dwg or jpg drawings. The selection software guides you within design rules and offers a comprehensive system design report under pdf, word or excel format.

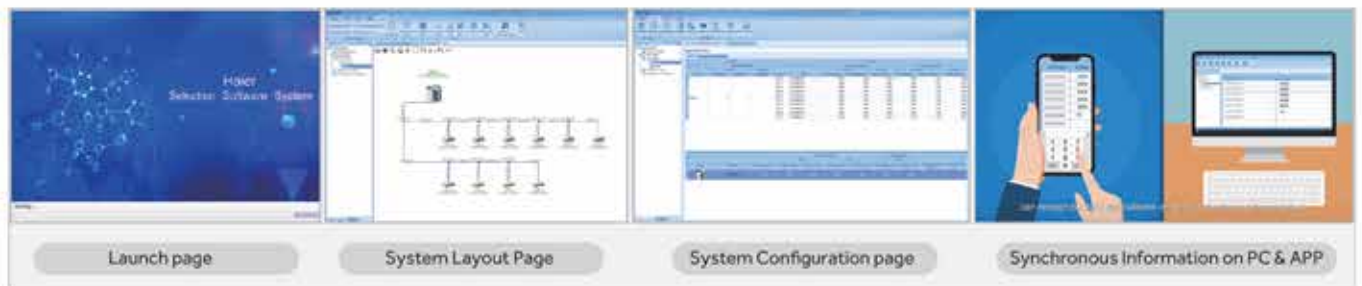

Service tool TD-03 with monitoring software



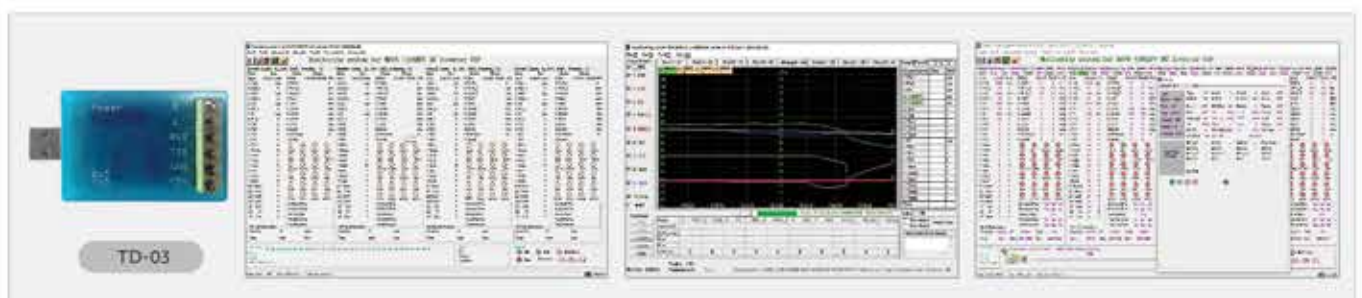













Installers can use TD-03 service tool together with monitoring software to realize real-time monitoring the operation data of VRF system through the PC. The running data and parameters can be used to analyze the error for fast troubleshooting. Also you can save the data for further analysis.



CONTROLLERS MATCH TABLE FOR MRV INDOOR UNITS

Outlook	Series	Model						
			YR-HRS01	YR-HQS01	HW-BA116ABK	HW-BA101ABT	YR-E17A	YR-E16B
	1-Way Cassette	AB**2MAERA	•	•	•	•	•	•
	Compact Cassette	AB**2MCERA(M)	•	•			•	•
	Round Way Cassette	AB**2MRERA	•	•			•	•
	Slim Duct (0/15/30Pa)	AD**2MSERA(D)	•			•	•	•
	High ESP Duct (20/200Pa)	AD**2MJERAD	•		•	•	•	•
	High ESP Duct (100-250Pa)	AD**2MGERA						•
	High Wall (N platform)	AS**2MNERA(B) AS**2MVERAC	•	•	•	•	•	•
	Fresh Air Duct	AD482MJERF AD722MTERF AD962MTERF			•	•	•	•

• Controllers can match with the indoor unit

Name	Design	Model	Functions	For what units
Gather pipe		HZG-20B	Refrigerant gathering for MRV IV, MRV 5	2 outdoor units
Gather pipe		HZG-30B	Refrigerant gathering for MRV IV, MRV 5	3 outdoor units
Gather pipe		HZG-R20B	Refrigerant gathering for MRV 5-RC	2 outdoor units
Gather pipe		HZG-R30B	Refrigerant gathering for MRV 5-RC	3 outdoor units
Gather pipe		HZG-R40B	Refrigerant gathering for MRV 5-RC	4 outdoor units
Manifold pipe		FQG-B335A	Refrigerant distribution for heat pump MRV	Total indoor units capacity less than 33,500W
Manifold pipe		FQG-B506A	Refrigerant distribution for heat pump MRV	Total indoor units capacity less than 50,600W, but equal or bigger than 33,500W
Manifold pipe		FQG-B730A	Refrigerant distribution for heat pump MRV	Total indoor units capacity less than 73,000W, but equal or bigger than 50,600W
Manifold pipe		FQG-B1350A	Refrigerant distribution for heat pump MRV	Total indoor units capacity less than 135,000W, but equal or bigger than 73,000W
Manifold pipe		FQG-R335A	Refrigerant distribution for heat recovery MRV	Total indoor units capacity less than 33,500W
Manifold pipe		FQG-R506A	Refrigerant distribution for heat recovery MRV	Total indoor units capacity less than 50,600W, but equal or bigger than 33,500W
Manifold pipe		FQG-R730A	Refrigerant distribution for heat recovery MRV	Total indoor units capacity less than 73,000W, but equal or bigger than 50,600W
Manifold pipe		FQG-R1350A	Refrigerant distribution for heat recovery MRV	Total indoor units capacity less than 135,000W, but equal or bigger than 73,000W
Manifold pipe		FQG-B2040A	Refrigerant distribution for heat pump	Total indoor capacity less than 204,000W but equal or bigger than 135,000W
Manifold pipe		FQG-R2040A	Refrigerant distribution for heat recovery	Total indoor capacity less than 204,000W but equal or bigger than 135,000W
VP box		VP1-112B, VP1-180B VP1-280B	Valve pipe box	MRV 5-RC(heat recovery)
VP box		VP4-450B	Valve pipe box	MRV 5-RC(heat recovery)

REFERENCE PROJECTS



Subway



Industrial



Education



Hospital



Offices



Hotel



Home & Apartment



Shop & Showroom

Reference Projects

Country: **Algeria**
Project Name: **Mobil Art**
Installation Series: **MRV-S&MRVIII**



Country: **Algeria**
Project Name: **AGB Bank**
Installation Series: **MRVII-C**



Country: **Algeria**
Project Name: **Hotel-Akbou Bedjaia**
Installation Series: **MRVII-C&MRVIII-C**



Country: **Algeria**
Project Name: **Mole Fix Office**
Installation Series: **MRVII-C**



Reference Projects

Country: **Algeria**
Project Name: **Ofarco Office**
Installation Series: **MRVII-S**



Country: **Algeria**
Project Name: **Telecom Com Office**
Installation Series: **MRVII-C**



Country: **Algeria**
Project Name: **Tapis office and showroom**
Installation Series: **MRVII-C**



Country: **Algeria**
Project Name: **Cabinda Stadium**
Installation Series: **MRVII-C**



Reference Projects

Country: **Czech Republic**
Project Name: **Outlet Arena Moravia**
Installation Series: **MRV-S + MRV5**



Country: **Czech Republic**
Project Name: **Geosan Group**
Installation Series: **MRVIII-C**



Country: **Czech Republic**
Project Name: **Pragolaktos**
Installation Series: **MRV-S + MRV5**



Country: **Cyprus**
Project Name: **Avlogyros**
Installation Series: **MRVII-C**



Reference Projects

Country: **Czech Republic**
Project Name: **DEK Stavebniny**
Installation Series: **MRV-S**



Country: **Cyprus**
Project Name: **Viva Souvenir Shop Ayia Napa**
Installation Series: **MRVII-C**



Country: **France**
Project Name: **Les Roches Rouges hotel**
Installation Series: **MRV IV**



Country: **Hungary**
Project Name: **Cordia City Garden Budapest**
Installation Series: **MRVII-C**



Reference Projects

Country: Italy
Project Name: Pantheon Hotel
Installation Series: MRV III-RC



Country: Italy
Project Name: Audi Shop
Installation Series: MRV 5+MRV S



Country: Italy
Project Name: Marina Hotel
Installation Series: MRV IV



Country: Italy
Project Name: Smooth Hotel
Installation Series: MRV III



Reference Projects

Country: **Italy**
Project Name: **Meininger Hotel**
Installation Series: **MRV III C Plus +MRV III -RC**



Country: **Indonesia**
Project Name: **St. Borromeus Hospital**
Installation Series: **MRVIII-C**



Country: **Indonesia**
Project Name: **Kosambi Apartement**
Installation Series: **MRV IV-C & SINGLE**



Country: **Israel**
Project Name: **Acro Real Estate High-end Residential Project**
Installation Series: **MRV SII**



Reference Projects

Country: **Malta**
Project Name: **St. Vincent de Paul Residence**
Installation Series: **MRV IV + MRV S**



Country: **Pakistan**
Project Name: **Interloop HD-2**
Installation Series: **MRV 5**



Country: Pakistan
Project Name: Lecole School
Installation Series: MRV IV



Country: Pakistan
Project Name: Khaadi Fabric Store Outlet at Com-3
Installation Series: MRV 5



Reference Projects

Country: **Pakistan**
Project Name: **CNS**
Installation Series: **MRV-3C PLUS**



Country: **Pakistan**
Project Name: **Dr. Ziauddin Hospital**
Installation Series: **MRV 5**



Country: **Pakistan**
Project Name: **Nagina Head Office's HVAC project**
Installation Series: **MRV 5**



Country: **Pakistan**
Project Name: **Cybernet Pakistan**
Installation Series: **MRV 5**



Reference Projects

Country: **Poland**
Project Name: **46 luxury apartments**
Installation Series: **3 MRV IV-C systems, 1 MRV III-S system**



Country: **Poland**
Project Name: **Hotel & conference center**
Installation Series: **MRV III-C**

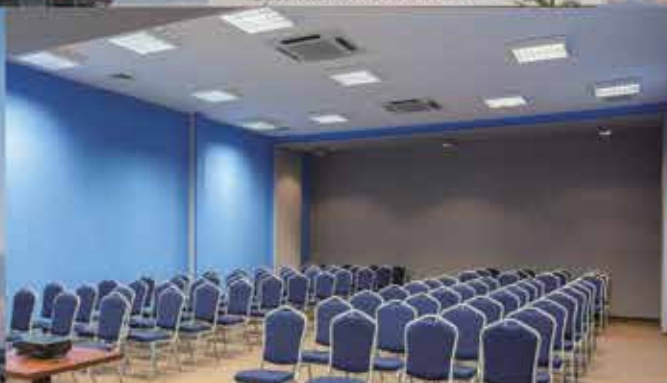

Country: **Poland**

Project Name: **4 separate building designated for buisness, retail and entertainment purposes**

Installation Series: **MRV III-C**



Country: **Poland**

Project Name: **Stadium**

Installation Series: **5 MRV III-S systems**



Reference Projects

Country: Poland
Project Name: 2000sq m, 3 story building
Installation Series: MRV III-C



Country: Republic of Malta
Project Name: Water front
Installation Series: MRV-IV



Country: **Russia**
Project Name: **Azimut**
Installation Series: **MRV III – C; MRV –S**



Country: **Spain**
Project Name: **IMadrid University Project**
Installation Series: **MRVIII-C**



Reference Projects

Country: **Spain**
Project Name: **Escuela de Hosteleria de Jerez**
Installation Series: **MRV III Plus**



Country: **Spain**
Project Name: **Guardería Hospital Niño Jesús**
Installation Series: **MRV-S**



Country: Thailand
Project Name: The South Cuisine
Installation Series: MRV III c-Plus



Country: Thailand
Project Name: Royal Lee Dimension
Installation Series: MRV IV



Reference Projects

Country: **Turkey**
Project Name: **Caspian Shopping Center**
Installation Series: **MRV 5**



Country: **Thailand**
Project Name: **Uttaradit Hospital**
Installation Series: **MRV III c-Plus**



Country: **Thailand**
Project Name: **Wandee Culinary Cook School**
Installation Series: **MRV III-C PLUS**



Country: **Ukraine**
Project Name: **IT-Center**
Installation Series: **MRV 5**



Date

/

/



Haier

Haier

Haier Intelligent Buildings

Australia 1300 729 948 | haier.com.au
New Zealand 0800 424 372

i The specifications, designs and information in this brochure are subject to the actual products.
Haier reserves the right to make change without any notice.

Sep., 2022

Version 1.0