

Haier SERVICE MANUAL

AC2007S001V1.1

Wall Mounted Type

INDOOR

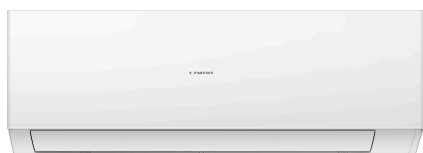

AS71PEGHRA AAD6Q0E00

OUTDOOR

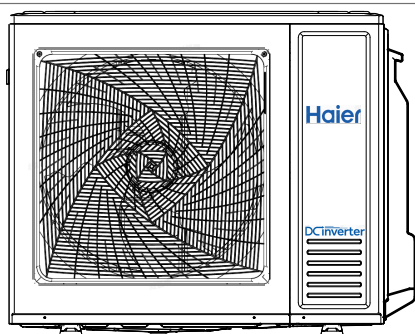

1U71XAGFRA AAD6N0E00

WARNING

This service information is designed for experienced repair technicians only and is not designed for use by the general public. It does not contain warnings or cautions to advise non-technical individuals of potential dangers in attempting to service a product. Products powered by electricity should be serviced or repaired only by experienced professional technicians. Any attempt to service or repair the product or products dealt with in this service information by anyone else could result in serious injury or death.

(Qing dao Haier Air Conditioner General corp. , Ltd)
All rights reserved. Unauthorized copying and distribution are a violation of law

1. INDOOR UNIT



Model No. AS71PEGHRA AAD6Q0E00

Contents

1.INDOOR UNIT

1.Introduction.....	1
2.Features	7
3.Specifications	8
4.Sensors list.....	9
5.Printed Circuit Board Connector Wiring Diagram.....	10
6.Functions and Control	13
7.Dimensional drawings	24
8. Capacity Table And Long Distance Air Supply.....	25
9.Center of gravity.....	26
10. Service Diagnosis	26
11.Circuit diagrams.....	27
12.Removal Procedure.....	30
13.Operation Manual.....	39

1 Introduction

1.1 Model name explanation

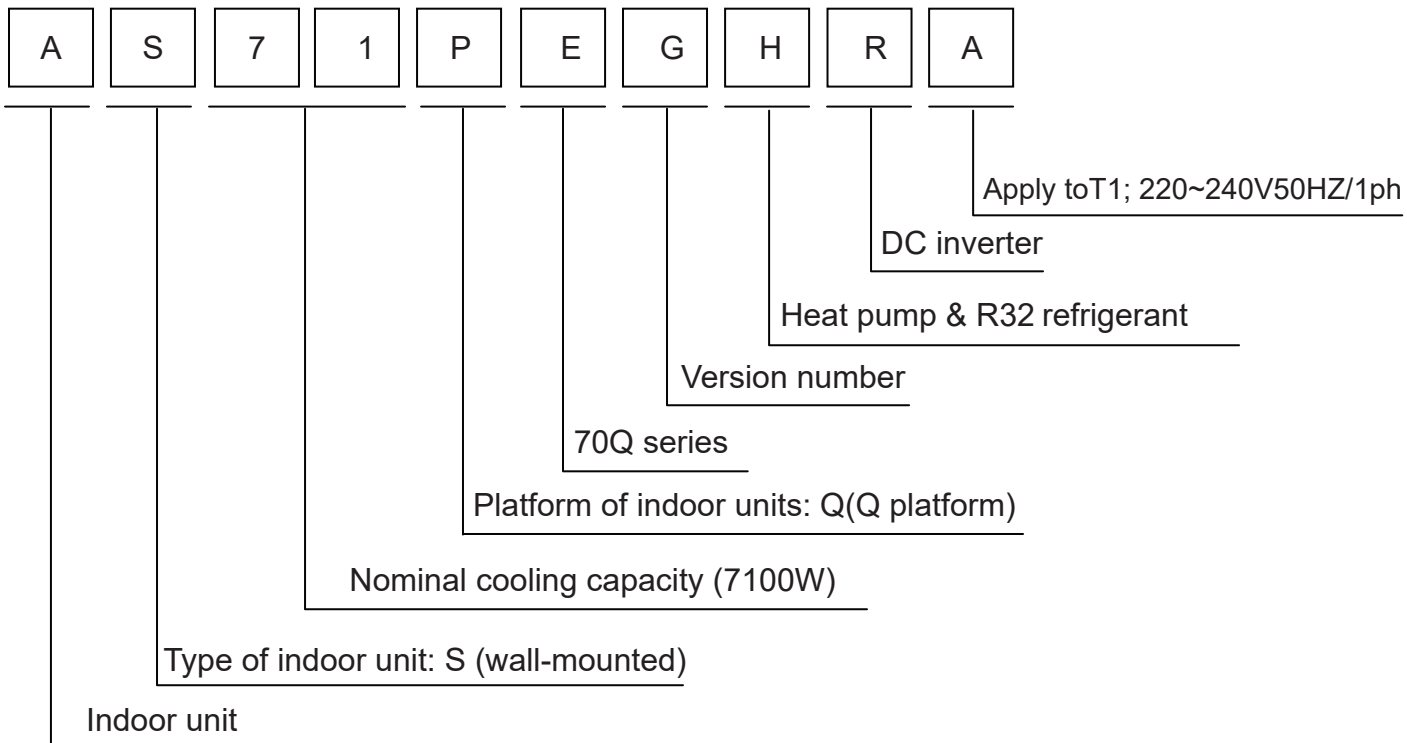

1.2 Safety Cautions

Be sure to read the following safety cautions before conducting repair work.

The caution items are classified into “Warning” and “Caution”. The “Warning” items are especially important since they can lead to death or serious injury if they are not followed closely. The “Caution” items can also lead to serious accidents under some conditions if they are not followed. Therefore, be sure to observe all the safety caution items described below.

About the pictograms

△ This symbol indicates an item for which caution must be exercised.

The pictogram shows the item to which attention must be paid.

○ This symbol indicates a prohibited action.





The prohibited item or action is shown inside or near the symbol.







● This symbol indicates an action that must be taken, or an instruction.

The instruction is shown inside or near the symbol.

After the repair work is complete, be sure to conduct a test operation to ensure that the equipment operates Normally, and explain the cautions for operating the product to the customer.



1.2.1 Caution in Repair

Warning	
<p>Be sure to disconnect the power cable plug from the plug socket before disassembling the equipment for a repair.</p> <p>Working on the equipment that is connected to a power supply can cause an electrical shock.</p> <p>If it is necessary to supply power to the equipment to conduct the repair or inspecting the circuits, do not touch any electrically charged sections of the equipment.</p>	
<p>If the refrigerant gas discharges during the repair work, do not touch the discharging refrigerant gas. The refrigerant gas can cause frostbite.</p>	
<p>When disconnecting the suction or discharge pipe of the compressor at the welded section, release the refrigerant gas completely at a well-ventilated place first.</p> <p>If there is a gas remaining inside the compressor, the refrigerant gas or refrigerating machine oil discharges when the pipe is disconnected, and it can cause injury.</p>	
<p>If the refrigerant gas leaks during the repair work, ventilate the area. The refrigerant gas can generate toxic gases when it contacts flames.</p>	
<p>The step-up capacitor supplies high-voltage electricity to the electrical components of the outdoor unit.</p> <p>Be sure to discharge the capacitor completely before conducting repair work. A charged capacitor can cause an electrical shock.</p>	
<p>Do not start or stop the air conditioner operation by plugging or unplugging the power cable plug.</p> <p>Plugging or unplugging the power cable plug to operate the equipment can cause an electrical shock or fire.</p>	

Warning	
Do not repair the electrical components with wet hands . Working on the equipment with wet hands can cause an electrical shock	
Do not clean the air conditioner by splashing water. Washing the unit with water can cause an electrical shock.	
Be sure to provide the grounding when repairing the equipment in a humid or wet place, to avoid electrical shock.	
Be sure to turn off the power switch and unplug the power cable when cleaning the equipment. The internal fan rotates at a high speed, and cause injury.	
Do not tilt the unit when removing it. The water inside the unit can spill and wet the furniture and floor.	
Be sure to check that the refrigerating cycle section has cooled down sufficiently before conducting repair work. Working on the unit when the refrigerating cycle section is hot can cause burns.	
Use the welder in a well-ventilated place. Using the welder in an enclosed room can cause oxygen deficiency.	



1.2.2 Cautions Regarding Products after Repair

Warning	
Be sure to use parts listed in the service parts list of the applicable model and appropriate tools to conduct repair work. Never attempt to modify the equipment. The use of inappropriate parts or tools can cause an electrical shock, excessive heat generation or fire.	
When relocating the equipment, make sure that the new installation site has sufficient strength to withstand the weight of the equipment. If the installation site does not have sufficient strength and if the installation work is not conducted securely, the equipment can fall and cause injury.	
Be sure to install the product correctly by using the provided standard installation frame. Incorrect use of the installation frame and improper installation can cause the equipment to fall, resulting in injury.	For integral units only
Be sure to install the product securely in the installation frame mounted on a window frame. If the unit is not securely mounted, it can fall and cause injury.	For integral units only

Warning	
<p>Be sure to use an exclusive power circuit for the equipment, and follow the technical standards related to the electrical equipment, the internal wiring regulations and the instruction manual for installation when conducting electrical work.</p> <p>Insufficient power circuit capacity and improper electrical work can cause an electrical shock or fire.</p>	
<p>Be sure to use the specified cable to connect between the indoor and outdoor units. Make the connections securely and route the cable properly so that there is no force pulling the cable at the connection terminals.</p> <p>Improper connections can cause excessive heat generation or fire.</p>	
<p>When connecting the cable between the indoor and outdoor units, make sure that the terminal cover does not lift off or dismount because of the cable.</p> <p>If the cover is not mounted properly, the terminal connection section can cause an electrical shock, excessive heat generation or fire.</p>	
<p>Do not damage or modify the power cable.</p> <p>Damaged or modified power cable can cause an electrical shock or fire. Placing heavy items on the power cable, and heating or pulling the power cable can damage the cable.</p>	
<p>Do not mix air or gas other than the specified refrigerant (R32) in the refrigerant system.</p> <p>If air enters the refrigerating system, an excessively high pressure results, causing equipment damage and injury.</p>	
<p>If the refrigerant gas leaks, be sure to locate the leak and repair it before charging the refrigerant. After charging refrigerant, make sure that there is no refrigerant leak.</p> <p>If the leak cannot be located and the repair work must be stopped, be sure to perform pump-down and close the service valve, to prevent the refrigerant gas from leaking into the room. The refrigerant gas itself is harmless, but it can generate toxic gases when it contacts flames, such as fan and other heaters, stoves and ranges.</p>	
<p>When replacing the coin battery in the remote controller, be sure to disposed of the old battery to prevent children from swallowing it.</p> <p>If a child swallows the coin battery, see a doctor immediately.</p>	

Caution	
Installation of a leakage breaker is necessary in some cases depending on the conditions of the installation site, to prevent electrical shocks.	
Do not install the equipment in a place where there is a possibility of combustible gas leaks. If a combustible gas leaks and remains around the unit, it can cause a fire.	
Be sure to install the packing and seal on the installation frame properly. If the packing and seal are not installed properly, water can enter the room and wet the furniture and floor.	

1.2.3 Inspection after Repair

Warning	
Check to make sure that the power cable plug is not dirty or loose, then insert the plug into a power outlet all the way. If the plug has dust or loose connection, it can cause an electrical shock or fire.	
If the power cable and lead wires have scratches or deteriorated, be sure to replace them. Damaged cable and wires can cause an electrical shock, excessive heat generation or fire.	





Warning	
Do not use a joined power cable or extension cable, or share the same power outlet with other electrical appliances since it can cause an electrical shock, excessive heat generation or fire.	

Caution	
Check to see if the parts and wires are mounted and connected properly, and if the connections at the soldered or crimped terminals are secure. Improper installation and connections can cause excessive heat generation, fire or an electrical shock.	
If the installation platform or frame has corroded, replace it. Corroded installation platform or frame can cause the unit to fall, resulting in injury.	
Check the grounding, and repair it if the equipment is not properly grounded. Improper grounding can cause an electrical shock.	
Be sure to measure the insulation resistance after the repair, and make sure that the resistance is 1 M ohm or higher. Faulty insulation can cause an electrical shock.	
Be sure to check the drainage of the indoor unit after the repair. Faulty drainage can cause the water to enter the room and wet the furniture and floor.	

1.2.4 Using Icons

Icons are used to attract the attention of the reader to specific information. The meaning of each icon is described in the table below:

1.2.5 Using Icons List

Icon	Type of Information	Description
 Note	Note	A “note” provides information that is not indispensable, but may nevertheless be valuable to the reader, such as tips and tricks.
 Caution	Caution	A “caution” is used when there is danger that the reader, through incorrect manipulation, may damage equipment, lose data, get an unexpected result or has to restart (part of) a procedure.
 Warning	Warning	A “warning” is used when there is danger of personal injury.
	Reference	A “reference” guides the reader to other places in this binder or in this manual, where he/she will find additional information on a specific topic.

2 Features



Super quiet: Lower noise operation condition



A-PAM DC inverter: With adoption of S-TYPE, S-PAM and PHASE control technology to works more stably at low-frequency, and is more energy-saving, more powerful at high frequency.



Long distance air supplying: The furthest air distance is 20 meters.



-15°C Heating: When -15°C can still heating natural



10°C heating maintenance: Heating Holding 10°C temperature



Comfortable sleep: The setting temperature and the indoor noise can be adjusted to a more comfortable level when you set the "sleep mode" during night sleep.



Super match: One outdoor unit can match two or more indoor unit.



DIY auto mode: Adjust the last fixed operation mode automatically.



Turbo mode: Quick cooling or heating



Auto restart: Automatic return to previous operation conditions after sudden power blackout



24 hours timer: Use the timer function to set on, or off, or from on to off, or from off to on.



Intergrative valve cover: The valve cover is Intergrative.



2-way piping design: The pipe can shoot out both from left or right side.



Easy clean design: The panel is easy to wash and the airflow vents can be detached easily



Double 8 display: The display is Double 8 mode.

3 Specifications

3.1 Specifications -AS71PEGHRA

NOMINAL DISTRIBUTION SYSTEM VOLTAGE				
Phase	/	1		
Frequency	Hz	50		
Voltage	V	220~240		
NOMINAL CAPACITY and NOMINAL INPUT				
		cooling	heating	
Capacity rated	KW	7.1	8.0	
	Btu/h	/	/	
Power Consumption(Rated)	KW	1.86	2.14	
EER/COP	W/W	3.82	3.74	
Moisture Removal	m ³ /h	3.0*10 ⁻³		
TECHNICAL SPECIFICATIONS				
Dimensions	H*W*D	mm	1105x240x345	
Packaged Dimensions	H*W*D	mm	1185x428x331	
Weight	/	KG	15.5	
Gross weight	/	KG	18.5	
Color	/	/	White	
Sound level	Sound pressure(high/medium/low)	dB	53/49/46	
	Sound power(fixed frequency)	dB(A)	67	
Piping Connections	Liquid	mm	φ6.35×0.8	
	Gas	mm	φ15.88×0.8	
TECHNICAL SPECIFICATIONS-PARTS				
		cooling	heating	
Fan	Type		Cross flow fan	
	Motor output	W	40	40
	Air flow rate(high)	m ³ /h	1100	1000
	Speed(super/high/low)	rpm	1150/1000/850	950/850/750
Heat exchanger	Type		ML fin- φ 7HI-HX tube	
	Segment *stage*fitch		3*14*1.4	
Air direction control		Right,Left,Horizontal,Downward		
Air filter		Removable/Washable/Mildew Proof		
Temperature control		Microcomputer Control		
Remote controller model		HJ		

Note: the data are based on the conditions shown in the table below

cooling	heating	Piping length
Indoor: 27°CDB/19°CWB Outdoor: 35°CDB/24°CWB	Indoor:20°CDB Outdoor: 7°CDB/6°CWB	5m

Conversion formulae
Kcal/h= KW×860
Btu/h= KW×3414
cfm=m ³ /min×35.3

4 Sensors list

type	Description	Qty
Room sensor	Its used for detecting room temperature	1
Pipe sensor	Its used for detecting temperature of evaporator	1

5 Printed Circuit Board Connector Wiring Diagram

Connectors

PCB(1) (Control PCB)

- 1) CN9 Connector for fan motor
- 2) CN6 Connector for heat exchanger thermistor and Room temperature thermistor
- 3) CN5' Connector for UP&DOWN STEP motor
- 4) CN11' Connector for RIGHT&LEFT STEP motor
- 5) CN21 (blue line)、CN17(deepred line) Connector for indoor terminal N and L
- 6) CN7 Connector for display board
- 7) CN23' (red line) Connector for communicate between the indoor board and the outdoor board
- 8) CN35 Connector for wifi Module
- 9) CN8 Connector for UVC
- 10) CN4 connector for magnetic switch

Note: Other designations

PCB(1) (Indoor Control PCB)

- 1) CN14 Connector for Forced operation ON / OFF switch
- 2) FUSE1 Fuse 3.15A/250VAC

	ON	OFF		3	ON	ON	OFF	OFF
1	A	B		4	ON	OFF	ON	OFF
2	N_RC	RC			35	33	26	23

J1	OFF	OFF	ON	ON
J2	OFF	ON	OFF	ON
DISPLAY SERIES	325 798	324	387	317

UNIT MOUDLE	PCB MOUDLE	1	2	3	4	DISPLAY MOUDLE	J1	J2
AS71PEGHRA	0011801675AU(23)	OFF	OFF	OFF	OFF	0011800989	ON	OFF

PCB(1)

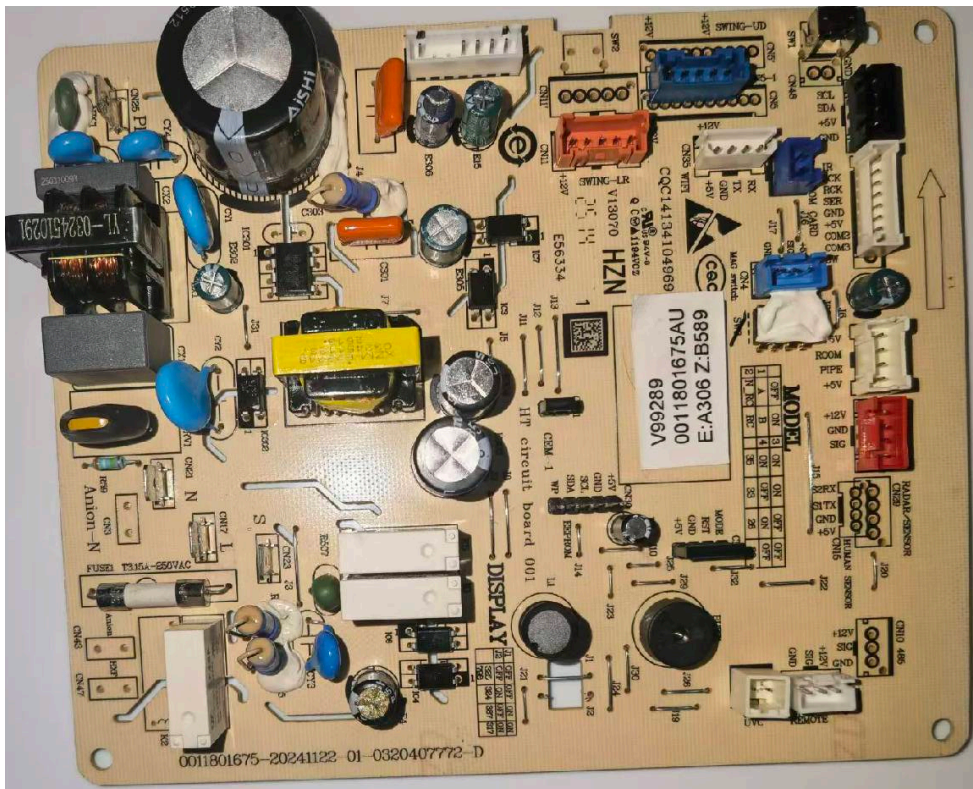
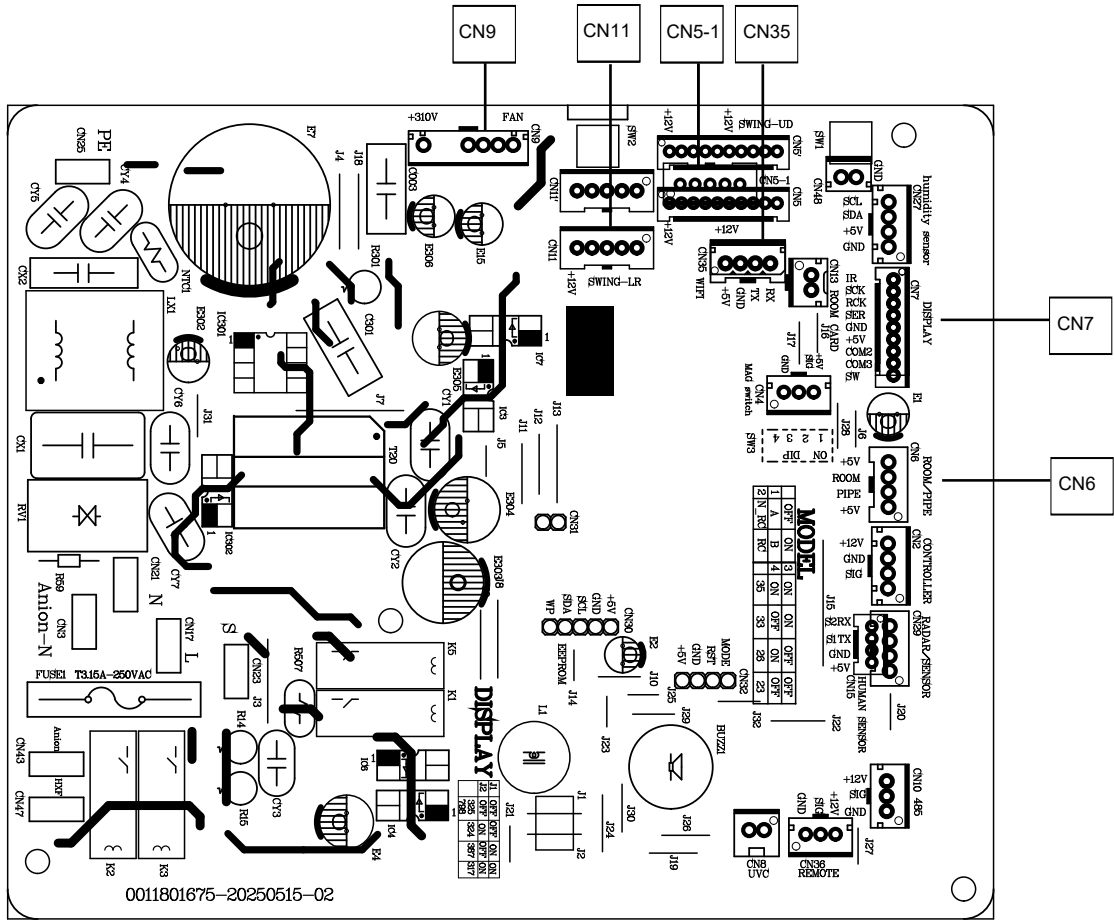

Wiring diagrams

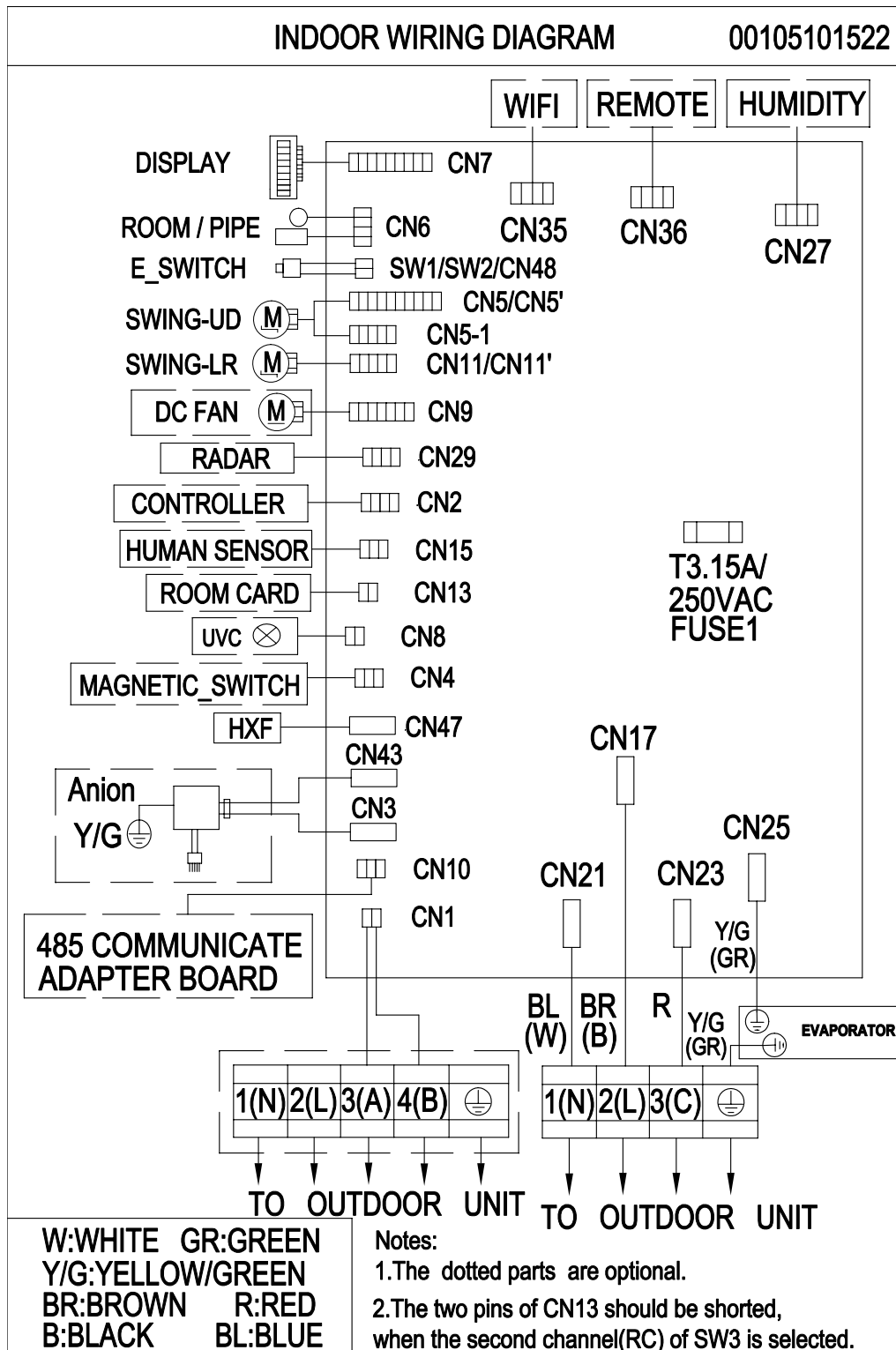

6 Functions and control

6.1 Main functions and control specification

6.1.1 Automatic operation

When the running mode is turned to automation after starting the system, the system will first determine the running mode according to the current room temperature and then will run according to the determined mode. T_r in the following selection conditions means room temperature, T_s means setting temperature, T_p means temperature of indoor coil pipe

$T_r \geq T_s - 3^\circ\text{C}$	Choose Cooling Mode
$T_r < T_s - 3^\circ\text{C}$	Choose Heating Mode

After turning to the automation mode, the running mode can be switched between cooling mode, fan mode and heating mode according to the change of the indoor ambient temperature. But the automatic conversion between cooling mode and heating mode must be conducted after 15 minutes.

6.1.2 Cooling operation mode

Temperature control range: $16^\circ\text{C} \text{---} 30^\circ\text{C}$

Temperature difference: $\pm 1^\circ\text{C}$

* Control features: When T_r (input airflow) $> T_s$ (set temperature) + temperature Backlash A, the compressor will be opened, the indoor fan will operate at the set speed and the mode signal will be sent to the outdoor system. When T_r (input airflow) $< T_s$ (set temperature) - temperature Backlash B, the compressor will be shutted, the indoor fan will operate at the set speed and the mode signal will be sent to the outdoor system. The system will keep the original status if $T_r = T_s$.

Airflow speed control: (temperature difference 1°C)

Automatic: When $T_r \leq T_s + 3^\circ\text{C}$, high speed.

When $T_s + 1^\circ\text{C} \leq T_r < T_s + 3^\circ\text{C}$, medium speed

When $T_r < T_s + 1^\circ\text{C}$, low speed

When the sensor is off, low speed

When the airflow speed has no delay from the high to low switching, the speed should be delayed for 3 minutes (remain at high speed for 3 minutes.) before the next switch.

Manus: When the system is operating, you can set the high, medium or low speed manually. (When the sensor is on or off, the system will change the speed 2 seconds after receiving the signal.)

*Airgate location control: the location for the airgate can be set according to your needs.

*Defrosting function: preventing the frosting on the indoor heat exchanger (when cooling or dehumidifying). When the compressor works continuously for 6 minutes and the temperature of the indoor coils has been below one centigrade for 10 seconds, the compressor will be stopped and the malfunction will be recorded in the malfunction list. The indoor system will continue to run. When the temperature of the indoor coil is raised to 9°C , the compressor will be restarted again (the requirement of 3 minutes' delay should be satisfied.)

*timing system on/off function.

*Dormant control function.

6.1.3 Dry mode

* temperature control range: 16---30℃

* temperature difference: $\pm 1^{\circ}\text{C}$

Control feature: send the dehumidifying signal to the outdoor system.

When $T_r > T_s + 2^{\circ}\text{C}$, the compressor will be turned on, the indoor fan will operate at the set speed. When T_r is between the T_s and $T_s + 2^{\circ}\text{C}$, the outdoor system will operate at the high dehumidifying frequency for 10 minutes and then at the low dehumidifying mode for six minutes. The indoor fan will operate at low speed.

When $T_r < T_s - 1.5^{\circ}\text{C}$, the outsystem will be stopped, the indoor fan will be stopped for 3 minutes and then turned to the low speed option.

All the frequency converses have a $\pm 1^{\circ}\text{C}$ difference.

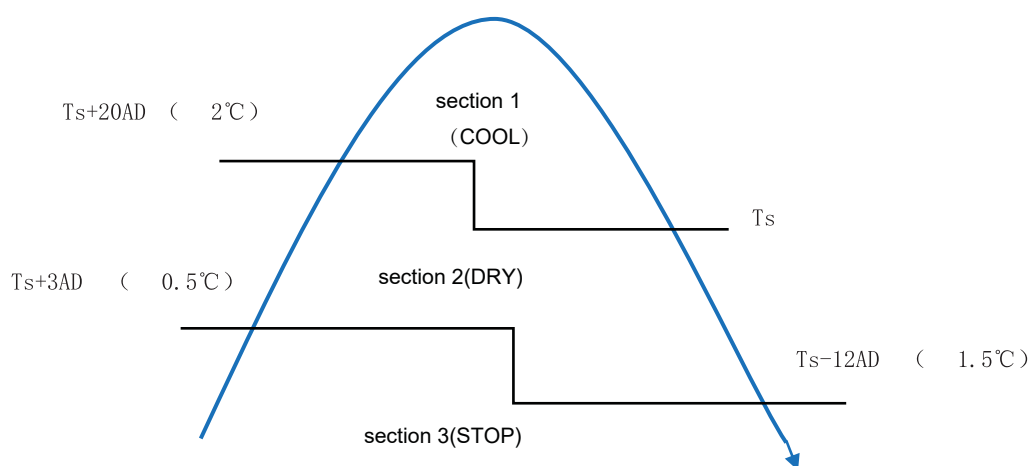

* Wind speed control: Automatic:

When $T_r \geq T_s + 5^{\circ}\text{C}$, high speed.

When $T_s + 3^{\circ}\text{C} \leq T_r < T_s + 5^{\circ}\text{C}$, medium speed.

When $T_s + 2^{\circ}\text{C} \leq T_r < T_s + 3^{\circ}\text{C}$, low speed.

When $T_r < T_s + 2^{\circ}\text{C}$, light speed.

If the outdoor fan stopped, the indoor fan will be paused for 3 minutes.

If the outdoor fan stopped for more than 3 minutes and the outdoor system still operates, the system will be changed into light speed mode.

When the airflow speed has no delay from the high to low switching, the speed should be delayed for 3 minutes (remain at high speed for 3 minutes.) before the next switch.

Manual: When the sensor is off or $T_r < T_s + 3^{\circ}\text{C}$, the manual operation can not be made. (obligatory automatic operation.)

*Airgate location control: the location for the airgate can be set according to your needs.

*Defrosting function: preventing the frosting on the indoor heat exchanger (when cooling or dehumidifying). When the compressor works continuously for 6 minutes and the temperature of the indoor coils has been below 1°C for 10 seconds, the compressor will be stopped and the malfunction will be recorded in the malfunction list. The indoor system will continue to run. When the temperature of the indoor coil is raised to 9°C, the compressor will be restarted again (the requirement of 3 minutes' delay should be satisfied.)

* Coil protection (synchronic overheating protection) are installed for the four directions latch malfunctions when dehumidifying.

* Timing system on/off function.

* Dormant control function.

6.1.4 Heating operation mode

* temperature control range: 16---30°C

* temperature difference: $\pm 1^\circ\text{C}$

* control feature: the temperature compensation is automatically added and the system will send the heating signals to the outdoor system.

If $Tr+0.5^\circ\text{C} \leq Ts$, the outdoor compressor is turned on, the indoor fan will be at the cold air proof mode.

If $Tr > Ts+1.5^\circ\text{C}$, the outdoor system is turned off, the indoor fan will be at the heat residue sending mode.

* Indoor fan control

manual control: You can choose high, medium, low and automatic speed control.

Automatic: When $Tr < Ts$, high speed.

When $Ts \leq Tr < Ts+2^\circ\text{C}$, medium speed.

When $Tr > Ts+2^\circ\text{C}$, low speed.

When the airflow speed has no delay from the high to low switching, the speed should be delayed for 3 minutes (remain at high speed for 3 minutes.) before the next switch.

*Airgate location control: the location for the airgate can be set according to your needs.

Coldair proof operation

1. The fan control functions as below:

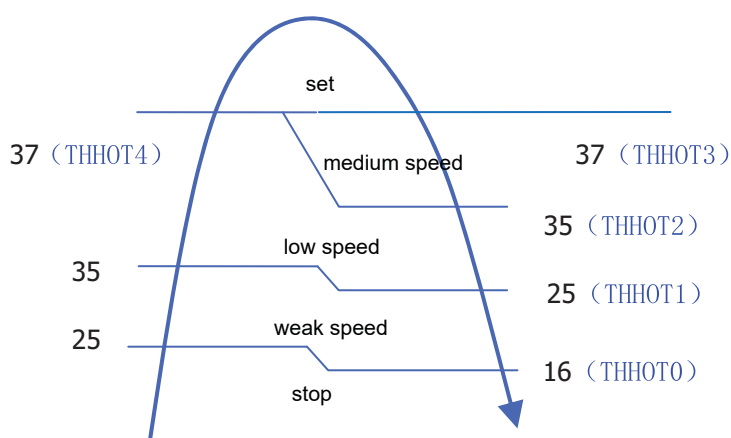

- * Residue heat sending. The indoor fan will send the residue heat at a low speed for 20 seconds. If other conditions are satisfied, when the compressor stops, the indoor system will operate at a light speed. The indoor fan will stop when the coil temperature is below the THHOT0.
- * Defrosting. When the system receives the defrosting signal from outdoors, the indoor fan will stop and the indoor temperature display won't change. At the time, any indoor coil malfunctions will be neglected. When the outdoor defrosting finishes, the coil malfunction will still be neglected until the compressor has been started up for 30 seconds. The indoor temperature display will not change and the system operates at the cold air proof mode.
- * Automatic heating temperature compensation: when the system enters the heating mode, the temperature compensation (4°C) will be added. When the status is switched off, the compensation will be erased.

6.1.5 Turbo function

The system enters the mode after receiving the 'strength signal'.

Send strength operation signal to the outdoor system.

The mode change finishes the strength operation.

Entering 'mute', you can have normal operation or signal control such as timing to finish the strength operation.

When the system is at the automatic option with the strength/ mute function, if the system enters the cooling mode, the cooling strength/ mute function will be offered; if the system enters the heating mode, then the heating strength/ mute function will be offered; if the system enters the airflow mode, there will be no strength/ mute function.

6.1.6 quiet function

The system enters the mode after receiving the 'mute signal'.

a. Mute heating: the airflow speed is slight, the system sends the mute signal to the outdoor system.

b. mute cooling: the airflow speed is slight, the system sends the mute signal to the outdoor system.

When the compressor operates, the airflow speed is mute speed. EEPROM is adaptable.

Mute operation can not work under the dehumidifying and airflow-sending operation.

6.1.7 Timing

You can set 24 hours' on/off timing accordingly. After the setting, the timing indicator will be lightened. Also, the light will be turning off after the timing is finished. The followings are several timing methods.

1.system /on timing: The timing indicator will be lightened and the indoor system is under the waiting mode. The light will be turned off when the timing is finished and the rest of the system will operate under a normal condition. The timing starts since the last reception of the timing signal.

2.system /off timing: When the system is turned on, the timing indicator is lightened, the rest of the system will operated under a normal condition. When set time comes, the indicator light will be turned off and the system will be turned off. If you have set the dormant functions, the order of your settings will be operated according to the timing settings.

3 .system /on and off timing: The settings will be completed according to the orders..

6.1.8 sleeping function

The dormant timing is an eight hours unadaptable one. The timing signs are shown on the V series board. (RC series show the dormant signal, the timing light is lighted on the 6 lights board).

2.1 Under the cooling/ dehumidifying operation, after the setting of the dormant operation, the set temperature will be raised for 1 centigrade after 1 hour's operation and will be raised for 1 centigrade 1 hour later. The system will keep this status for 6 hours and then close.

2.2 Under the heating mode, after the setting of the dormant operation, the setting temperature will fall 2 centigrade after 1 hour's operation and will fall 2 centigrade 1 hour later. 3 hours after the preceding operations, the set temperature will be raised for 1 centigrade and the system will keep this status for 3 hours and then close down.

2.3 During the dormant time, except the change of the system mode or a new press on the dormant setting keys, the timing of the 8 hours dormancy will take the first timing as the start time, any presses on other keys will not affect the original timing.

2.4 Indoor fan control under the dormant operation.

If the indoor fan is at the high speed before the dormant operation setting, the speed will be turned to medium after the setting. If the fan is at the medium speed before the dormant setting, the speed will be turned to low after the setting. If the fan is at the low speed before the dormant setting, the speed will not change.

6.1.9 Emergency switch function

Press the urgency button the buzzer will ring. The system will enter the automatic mode if you don't press the button for more than 5 seconds.

Under the system off mode, if you press the urgency key for 5 to 10 seconds, the system will start the test operation.

Under the system off mode, if you press the urgency key for 10 to 15 seconds, the display screen will show the resume of the last malfunction.

If the system is under operation, the press on the urgency key will stop it.

Under the system off mode, the display screen will show automatic running sign.

Under the system off mode, the system will not receive the remote control signal if the press on the urgency key doesn't last for 15 seconds or if the key is loosened.

Urgency operation: If you press the urgency key for less than 5 seconds, the buzzer will ring when you press the on/off key. The system will enter the urgency operation when the urgency key is loosened.

The urgency operation is fully automatic.

Test operation.

The inlet temperature sensor doesn't work, the indoor fan and the indoor air direction board motor works synchronically. High speed airflow, cooling, outdoor system on, etc, will send the ambient temperature 30 centigrade and coil temperature 16 centigrade information to the outdoor system.

Test operation

The defrost protection of the evaporator doesn't work.

The temperature control doesn't work.

The test operation will be finished in 30 minutes.

The test operation can be stopped by the relative commands from the remote control.

6.1.10 Low load protection control

In order to prevent the frosting of the indoor evaporator, the outdoor system will be stopped if the indoor heat interaction temperature is below 1°C centigrade for 5 minutes, but the fan will continue to operate. The outdoor system will be started again when the heat interaction temperature is above 9 centigrade and the system has been stopped for 3 minutes. The malfunction will be stored in the malfunction resume and will not be revealed

6.1.11 High load protection control

The outdoor system will be stopped if the coil temperature is above 63°C for 2 minutes. The indoor fan will be controlled by the thermostat. The outdoor system can be restarted when the coil temperature is below 45°C and the system has been stopped for 3 minutes. The malfunction will be stored in the malfunction resume and will not be revealed.

6.1.12 Single indoor system operation

- * Enter condition: First, set the high speed airflow and 30 centigrade set temperature, then press the dormant keys for 6 times within 7 seconds, the system will feedback with 6 rings.
- * After the system enters the separate indoor system operation mode, the indoor system will operate according to the set mode and neglect the communication signals of the outdoor system. However, it has to send signals to the outdoor system.
- * Quitting condition: This mode can be quitted after receiving the quitting signal from the remote control or urgency system. The indoor system thus can quit the single operation mode.

6.1.13 Auto restarted function

- * Entering condition: Press sleep button 10 times within 7 second, the buzzer will ring 4 times
- * Quitting conditions: Press dormant button 10 times within 7 seconds and the buzzer will ring twice.

6.2 Value of thermistor

Room sensor and Pipe Sensor

R25°C=10KΩ ±2%

B25°C/50°C=3700K±2%

Temp.((°C))	Max.(KΩ)	Normal(KΩ)	Min.(KΩ)	Tolerance(°C)	
-30	165.2170	147.9497	132.3678	-1.94	1.75
-29	155.5754	139.5600	125.0806	-1.93	1.74
-28	146.5609	131.7022	118.2434	-1.91	1.73
-27	138.1285	124.3392	111.8256	-1.89	1.71
-26	130.2371	117.4366	105.7989	-1.87	1.70
-25	122.8484	110.9627	100.1367	-1.85	1.69
-24	115.9272	104.8882	94.8149	-1.83	1.67
-23	109.4410	99.1858	89.8106	-1.81	1.66
-22	103.3598	93.8305	85.1031	-1.80	1.64
-21	97.6556	88.7989	80.6728	-1.78	1.63
-20	92.3028	84.0695	76.5017	-1.76	1.62
-19	87.2775	79.6222	72.5729	-1.74	1.60
-18	82.5577	75.4384	68.8710	-1.72	1.59
-17	78.1230	71.5010	65.3815	-1.70	1.57
-16	73.9543	67.7939	62.0907	-1.68	1.55
-15	70.0342	64.3023	58.9863	-1.66	1.54
-14	66.3463	61.0123	56.0565	-1.64	1.52
-13	62.8755	57.9110	53.2905	-1.62	1.51
-12	59.6076	54.9866	50.6781	-1.60	1.49
-11	56.5296	52.2278	48.2099	-1.58	1.47
-10	53.6294	49.6244	45.8771	-1.56	1.46
-9	50.8956	47.1666	43.6714	-1.54	1.44
-8	48.3178	44.8454	41.5851	-1.51	1.42
-7	45.8860	42.6525	39.6112	-1.49	1.40
-6	43.5912	40.5800	37.7429	-1.47	1.39
-5	41.4249	38.6207	35.9739	-1.45	1.37
-4	39.3792	36.7676	34.2983	-1.43	1.35
-3	37.4465	35.0144	32.7108	-1.41	1.33
-2	35.6202	33.3552	31.2062	-1.38	1.31
-1	33.8936	31.7844	29.7796	-1.36	1.29
0	32.2608	30.2968	28.4267	-1.34	1.28
1	30.7162	28.8875	27.1431	-1.32	1.26
2	29.2545	27.5519	25.9250	-1.29	1.24
3	27.8708	26.2858	24.7686	-1.27	1.22
4	26.5605	25.0851	23.6704	-1.25	1.20
5	25.3193	23.9462	22.6273	-1.23	1.18
6	24.1432	22.8656	21.6361	-1.20	1.16

7	23.0284	21.8398	20.6939	-1.18	1.14
8	21.9714	20.8659	19.7982	-1.15	1.12
9	20.9688	19.9409	18.9463	-1.13	1.09
10	20.0176	19.0621	18.1358	-1.11	1.07
11	19.1149	18.2270	17.3646	-1.08	1.05
12	18.2580	17.4331	16.6305	-1.06	1.03
13	17.4442	16.6782	15.9315	-1.03	1.01
14	16.6711	15.9601	15.2657	-1.01	0.99
15	15.9366	15.2770	14.6315	-0.98	0.96
16	15.2385	14.6268	14.0271	-0.96	0.94
17	14.5748	14.0079	13.4510	-0.93	0.92
18	13.9436	13.4185	12.9017	-0.91	0.90
19	13.3431	12.8572	12.3778	-0.88	0.87
20	12.7718	12.3223	11.8780	-0.86	0.85
21	12.2280	11.8126	11.4011	-0.83	0.83
22	11.7102	11.3267	10.9459	-0.81	0.80
23	11.2172	10.8634	10.5114	-0.78	0.78
24	10.7475	10.4216	10.0964	-0.75	0.75
25	10.3000	10.0000	9.7000	-0.75	0.75
26	9.8975	9.5974	9.2980	-0.76	0.76
27	9.5129	9.2132	8.9148	-0.80	0.80
28	9.1454	8.8465	8.5496	-0.84	0.83
29	8.7942	8.4964	8.2013	-0.87	0.86
30	8.4583	8.1621	7.8691	-0.91	0.90
31	8.1371	7.8428	7.5522	-0.95	0.93
32	7.8299	7.5377	7.2498	-0.98	0.97
33	7.5359	7.2461	6.9611	-1.02	1.00
34	7.2546	6.9673	6.6854	-1.06	1.04
35	6.9852	6.7008	6.4222	-1.10	1.07
36	6.7273	6.4459	6.1707	-1.13	1.11
37	6.4803	6.2021	5.9304	-1.17	1.14
38	6.2437	5.9687	5.7007	-1.21	1.18
39	6.0170	5.7454	5.4812	-1.25	1.22
40	5.7997	5.5316	5.2712	-1.29	1.25
41	5.5914	5.3269	5.0704	-1.33	1.29
42	5.3916	5.1308	4.8783	-1.37	1.33
43	5.2001	4.9430	4.6944	-1.41	1.36
44	5.0163	4.7630	4.5185	-1.45	1.40
45	4.8400	4.5905	4.3500	-1.49	1.44
46	4.6708	4.4252	4.1887	-1.53	1.47
47	4.5083	4.2666	4.0342	-1.57	1.51
48	4.3524	4.1145	3.8862	-1.61	1.55
49	4.2026	3.9686	3.7443	-1.65	1.59

50	4.0588	3.8287	3.6084	-1.70	1.62
51	3.9206	3.6943	3.4780	-1.74	1.66
52	3.7878	3.5654	3.3531	-1.78	1.70
53	3.6601	3.4416	3.2332	-1.82	1.74
54	3.5374	3.3227	3.1183	-1.87	1.78
55	3.4195	3.2085	3.0079	-1.91	1.82
56	3.3060	3.0989	2.9021	-1.95	1.85
57	3.1969	2.9935	2.8005	-2.00	1.89
58	3.0919	2.8922	2.7029	-2.04	1.93
59	2.9909	2.7948	2.6092	-2.08	1.97
60	2.8936	2.7012	2.5193	-2.13	2.01
61	2.8000	2.6112	2.4328	-2.17	2.05
62	2.7099	2.5246	2.3498	-2.22	2.09
63	2.6232	2.4413	2.2700	-2.26	2.13
64	2.5396	2.3611	2.1932	-2.31	2.17
65	2.4591	2.2840	2.1195	-2.36	2.21
66	2.3815	2.2098	2.0486	-2.40	2.25
67	2.3068	2.1383	1.9803	-2.45	2.29
68	2.2347	2.0695	1.9147	-2.49	2.34
69	2.1652	2.0032	1.8516	-2.54	2.38
70	2.0983	1.9393	1.7908	-2.59	2.42
71	2.0337	1.8778	1.7324	-2.63	2.46
72	1.9714	1.8186	1.6761	-2.68	2.50
73	1.9113	1.7614	1.6219	-2.73	2.54
74	1.8533	1.7064	1.5697	-2.78	2.58
75	1.7974	1.6533	1.5194	-2.83	2.63
76	1.7434	1.6021	1.4710	-2.88	2.67
77	1.6913	1.5528	1.4243	-2.92	2.71
78	1.6409	1.5051	1.3794	-2.97	2.75
79	1.5923	1.4592	1.3360	-3.02	2.80
80	1.5454	1.4149	1.2942	-3.07	2.84
81	1.5000	1.3721	1.2540	-3.12	2.88
82	1.4562	1.3308	1.2151	-3.17	2.93
83	1.4139	1.2910	1.1776	-3.22	2.97
84	1.3730	1.2525	1.1415	-3.27	3.01
85	1.3335	1.2153	1.1066	-3.32	3.06
86	1.2953	1.1794	1.0730	-3.38	3.10
87	1.2583	1.1448	1.0405	-3.43	3.15
88	1.2226	1.1113	1.0092	-3.48	3.19
89	1.1880	1.0789	0.9789	-3.53	3.24
90	1.1546	1.0476	0.9497	-3.58	3.28
91	1.1223	1.0174	0.9215	-3.64	3.33
92	1.0910	0.9882	0.8942	-3.69	3.37

93	1.0607	0.9599	0.8679	-3.74	3.42
94	1.0314	0.9326	0.8424	-3.80	3.46
95	1.0030	0.9061	0.8179	-3.85	3.51
96	0.9756	0.8806	0.7941	-3.90	3.55
97	0.9490	0.8558	0.7711	-3.96	3.60
98	0.9232	0.8319	0.7489	-4.01	3.64
99	0.8983	0.8088	0.7275	-4.07	3.69
100	0.8741	0.7863	0.7067	-4.12	3.74
101	0.8507	0.7646	0.6867	-4.18	3.78
102	0.8281	0.7436	0.6672	-4.23	3.83
103	0.8061	0.7233	0.6484	-4.29	3.88
104	0.7848	0.7036	0.6303	-4.34	3.92
105	0.7641	0.6845	0.6127	-4.40	3.97
106	0.7441	0.6661	0.5957	-4.46	4.02
107	0.7247	0.6482	0.5792	-4.51	4.07
108	0.7059	0.6308	0.5632	-4.57	4.12
109	0.6877	0.6140	0.5478	-4.63	4.16
110	0.6700	0.5977	0.5328	-4.69	4.21
111	0.6528	0.5820	0.5183	-4.74	4.26
112	0.6361	0.5667	0.5043	-4.80	4.31
113	0.6200	0.5518	0.4907	-4.86	4.36
114	0.6043	0.5374	0.4775	-4.92	4.41
115	0.5891	0.5235	0.4648	-4.98	4.45
116	0.5743	0.5100	0.4524	-5.04	4.50
117	0.5600	0.4968	0.4404	-5.10	4.55
118	0.5460	0.4841	0.4288	-5.16	4.60
119	0.5325	0.4717	0.4175	-5.22	4.65
120	0.5194	0.4597	0.4066	-5.28	4.70

7 Dimensional drawings

unit:mm

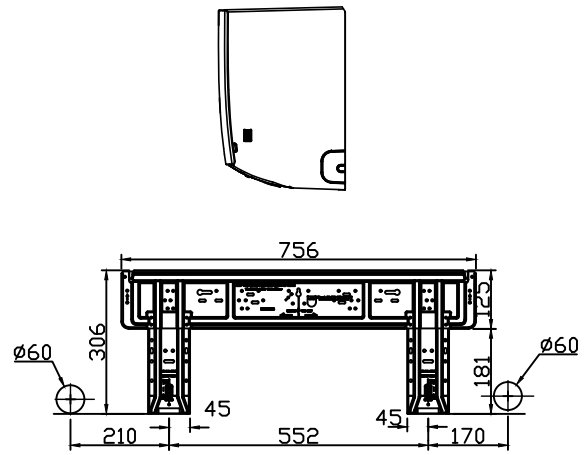
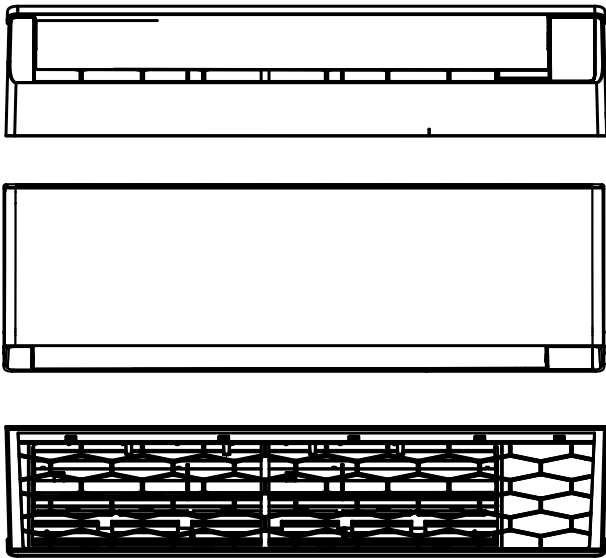

AS71PEGHRA

unit:mm

8. Center of gravity

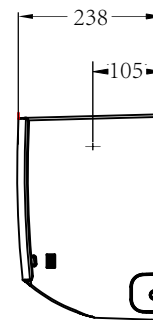
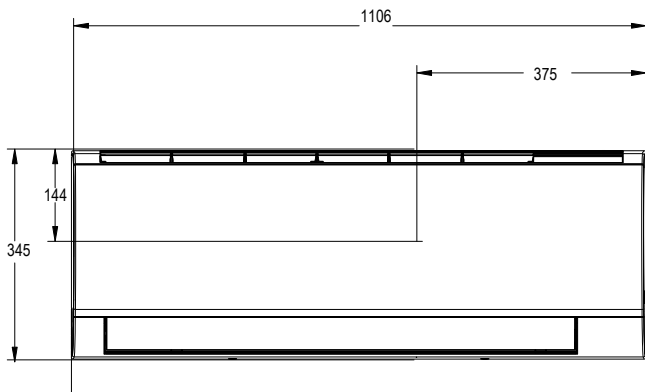

24K

9.Capacity Table

TC:total capacity SC: sensible capacity

9.1 AS71PEGHRA Cooling

WB: wet-bulb temperature DB:dry-bulb temperature

Outdoor temperature (°C DB)	Indoor temperature (°C WB/DB)													
	14/22		16/23		18/26		19/27		20/28		22/30		24/32	
	TC	SC	TC	SC	TC	SC	TC	SC	TC	SC	TC	SC	TC	SC
	kW	kW	kW	kW	kW	kW	kW	kW	kW	kW	kW	kW	kW	kW
10.0	5.17	4.91	6.03	4.82	6.82	5.46	7.18	5.46	7.54	5.50	8.62	5.51	9.33	5.41
12.0	4.93	4.69	5.75	4.60	6.51	5.21	6.85	5.21	7.19	5.25	8.22	5.26	8.91	5.16
14.0	4.83	4.59	5.64	4.51	6.37	5.10	6.71	5.10	7.05	5.14	8.05	5.15	8.72	5.06
16.0	4.77	4.53	5.57	4.46	6.30	5.04	6.63	5.04	6.96	5.08	7.96	5.09	8.62	5.00
18.0	4.70	4.47	5.49	4.39	6.20	4.96	6.53	4.96	6.86	5.01	7.84	5.02	8.49	4.92
20.0	4.62	4.38	5.38	4.31	6.09	4.87	6.41	4.87	6.73	4.91	7.69	4.92	8.33	4.83
21.0	4.50	4.28	5.25	4.20	5.94	4.75	6.25	4.75	6.56	4.79	7.50	4.80	8.13	4.71
23.0	4.41	4.19	5.15	4.12	5.82	4.66	6.13	4.66	6.44	4.70	7.36	4.71	7.97	4.62
25.0	4.49	4.26	5.23	4.19	5.92	4.73	6.23	4.73	6.54	4.78	7.48	4.78	8.10	4.70
27.0	4.56	4.34	5.33	4.26	6.02	4.82	6.34	4.82	6.66	4.86	7.61	4.87	8.24	4.78
29.0	4.64	4.41	5.42	4.33	6.13	4.90	6.45	4.90	6.77	4.94	7.42	4.75	7.74	4.49
31.0	4.82	4.58	5.62	4.50	6.36	5.08	6.69	5.08	7.02	5.13	7.69	4.92	8.03	4.66
33.0	4.91	4.66	5.73	4.58	6.48	5.18	6.82	5.18	7.16	5.23	7.84	5.02	8.18	4.75
35.0	5.05	4.80	5.90	4.72	6.67	5.34	7.02	5.34	7.37	5.38	8.07	5.17	8.42	4.89
37.0	4.90	4.66	5.72	4.58	6.47	5.18	6.81	5.18	7.15	5.22	7.83	5.01	8.17	4.74
39.0	4.69	4.45	5.47	4.37	6.18	4.95	6.51	4.95	6.84	4.99	7.49	4.79	7.81	4.53
42.0	4.54	4.32	5.30	4.24	5.99	4.80	6.31	4.80	6.63	4.84	7.26	4.64	7.57	4.39
44.0	4.43	4.21	5.17	4.13	5.84	4.67	6.15	4.67	6.46	4.71	7.07	4.53	7.38	4.28
46.0	4.33	4.11	5.05	4.04	5.71	4.57	6.01	4.57	6.31	4.61	6.91	4.42	7.21	4.18

< YU**h**[

TC:total capacity WB: wet-bulb temperature DB:dry-bulb temperature

Outdoor temperature (°C DB)		Indoor temperature (°C DB)											
		16		18		20		21		22		24	
		TC	SC	TC	SC	TC	SC	TC	SC	TC	SC		
WB	DB	kW	kW	kW	kW	kW	kW	kW	kW	kW	kW	kW	
-20	-19.8	4.46	4.46	4.21	4.21	4.04	4.04						
-19	-18.8	4.65	4.65	4.39	4.39	4.21	4.21						
-17	-16.7	4.90	4.90	4.62	4.62	4.44	4.44						
-15	-14.7	4.99	4.99	4.71	4.71	4.52	4.52						
-13	-12.6	5.33	5.33	5.03	5.03	4.83	4.83						
-11	-10.5	5.45	5.45	5.14	5.14	4.93	4.93						
-10	-9.5	6.03	6.03	5.69	5.69	5.46	5.46						
-9.1	-8.5	6.22	6.22	5.87	5.87	5.64	5.64						
-7.6	-7	6.38	6.38	6.02	6.02	5.78	5.78						
-5.6	-5	6.53	6.53	6.16	6.16	5.91	5.91						
-3.7	-3	6.66	6.66	6.28	6.28	6.03	6.03						
-0.7	0	7.12	7.12	6.72	6.72	6.45	6.45						
2.2	3	7.97	7.97	7.52	7.52	7.22	7.22						
4.1	5	7.77	7.77	7.33	7.33	7.03	7.03						
6	7	8.01	8.01	7.56	7.56	7.26	7.26						
7.9	9	7.87	7.87	7.42	7.42	7.12	7.12						
9.8	11	7.75	7.75	7.31	7.31	7.02	7.02						
11.8	13	7.58	7.58	7.15	7.15	6.86	6.86						
13.73	15	7.43	7.43	7.01	7.01	6.73	6.73						

9.2 Long Distance Air Supply



The Coanda airflow will achieve long throw:

Model	Airflow Distance
AS71PEGHRA/1U71XAGFRA	20m

10. Service Diagnosis

10.1 Caution for Diagnosis

The operation lamp flashes when any of the following errors is detected.

1. When a protection device of the indoor or outdoor unit is activated or when the thermistor malfunctions, disabling equipment operation.
2. When a signal transmission error occurs between the indoor and outdoor units. In either case, conduct the diagnostic procedure described in the following pages.

Parameter of primary electronic appliance

NO	Name	Parameter	Picture
1	Fan motor (0010401977L)	Rated input voltage: 310V/DC Rated load: 70W Rated speed: 1400 r/min Resistance of winding (25°C): 100Ω	

11. Circuit Diagrams

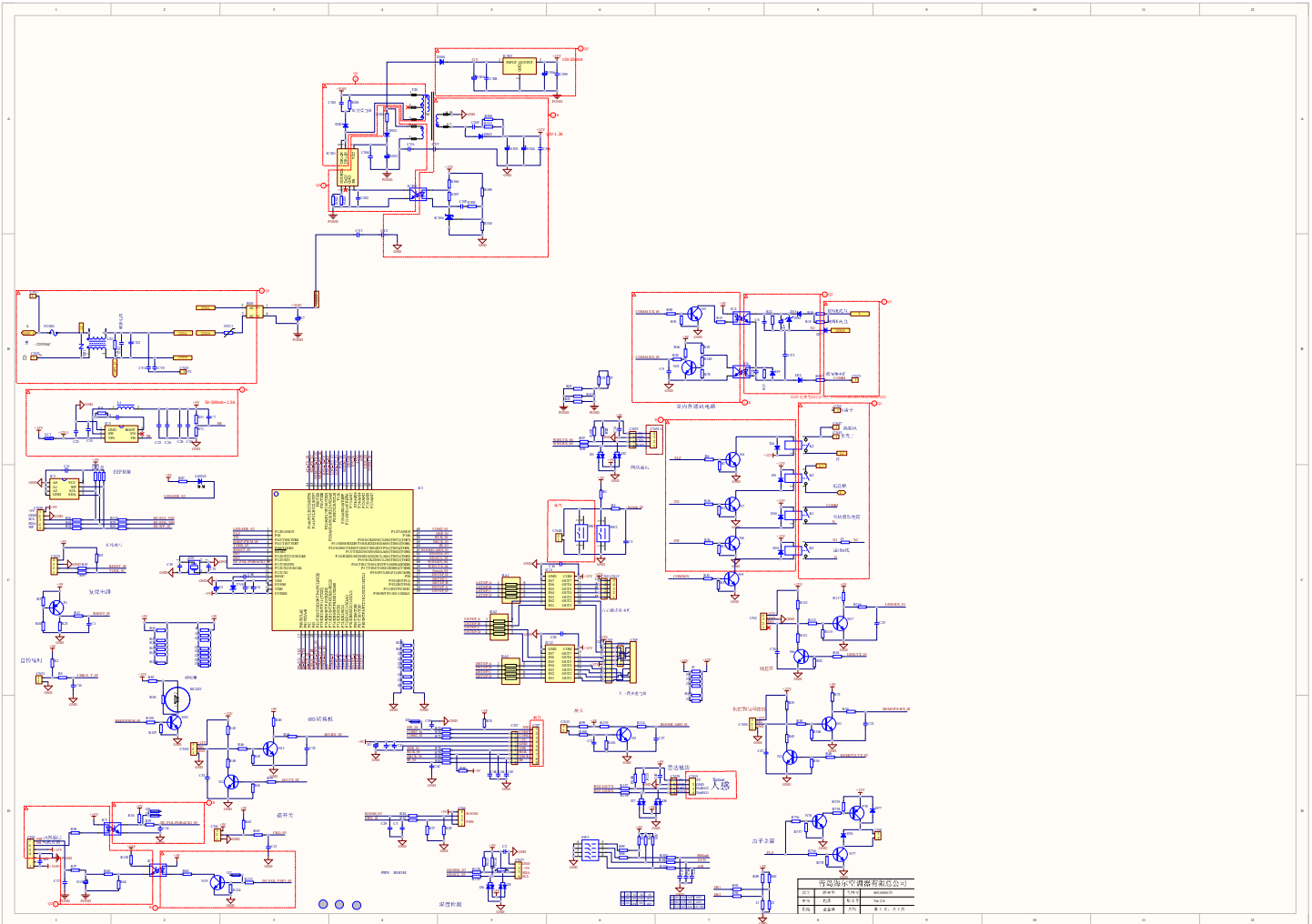

12 REMOVAL PROCEDURE

Indoor unit

Procedure

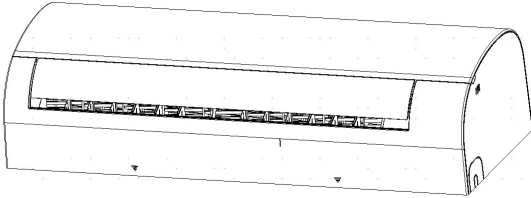
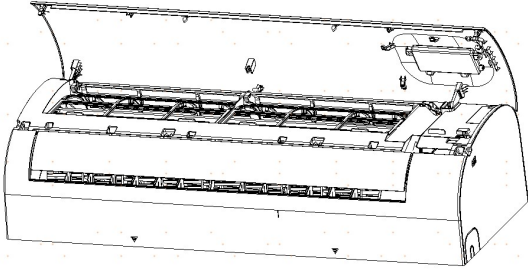
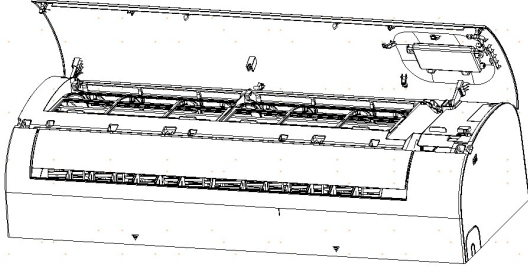

Warning Be sure to wait 10 minutes or more after turning off all power supplies before disassembling work.

Step	Procedure	Points
1. Features		
2. Remove the front panel	<p data-bbox="124 1350 387 1422">1 Release the four pieces of tape</p>  <p data-bbox="124 1693 427 1823">2 Hold the front panel by the tabs on the both sides and lift it until it</p> 	

Procedure



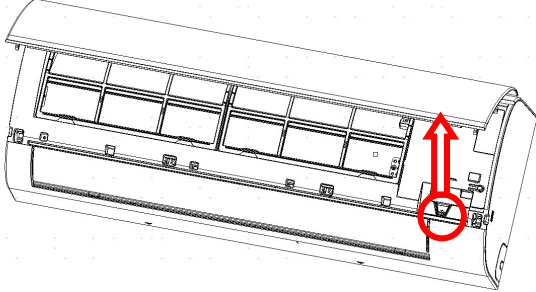
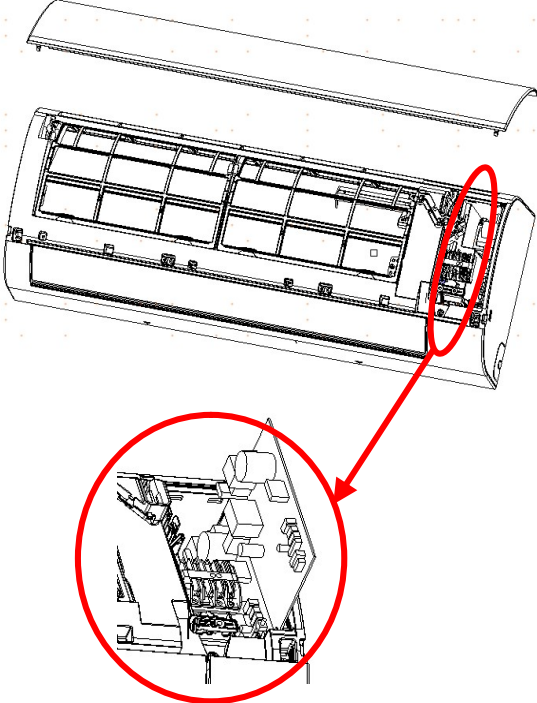

Warning Be sure to wait 10 minutes or more after turning off all power supplies before disassembling work.

Step		Procedure	Points
3	Loosen the screw and lift up the control box cover.		
4	Pull the Wires out of the control box and then release the pivots on both sides of the unit to remove the front panel.		

Procedure

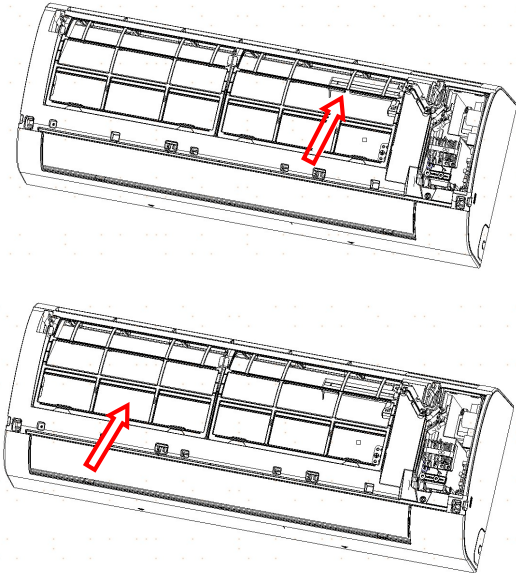

Warning Be sure to wait 10 minutes or more after turning off all power supplies before disassembling work.

Step	Procedure	Points
<p>3. Remove the air filters</p> <p>1</p>	<p>Lift an air filter upwards slightly and then pull it out downwards.</p> 	
<p>4. Remove the horizontal flap</p> <p>1</p>	<p>Release the side of pivot and then Release the Center of the pivot. Bend the horizontal blade slightly and remove it.</p> 	<p>■ The horizontal flap is Single.</p>

Procedure



Warning Be sure to wait 10 minutes or more after turning off all power supplies before disassembling work.

Step	Procedure	Points
<p>5. Remove the casing</p>		
<p>1</p>	<p>Release the screw covers(3EA)</p>	
<p>2</p>	<p>Loosen the marked Screw (6EA)</p>	
<p>3</p>	<p>Release the marked hooks (4EA) and then Pull the front grille out Horizontally and remove it.</p>	<ul style="list-style-type: none"> ■ When assembling, install the front grille horizontally so as not to stuff the flap inside. ■ When assembling, make sure the four hooks are caught properly.

Procedure



Warning Be sure to wait 10 minutes or more after turning off all power supplies before disassembling work.

Step	Procedure	Points
<p>6. Release stepping motor and control box</p>		
<p>1</p> <p>Release the top cover of the control box hooks and then remove it.</p>		
<p>2</p> <p>Pull the Harness out of the PCB unit and then Loosen the control Box screws (2EA) . Pull the control box from of the frame and remove it.</p>		<p>Harness: Stepping motor and fan motor harness</p>
<p>3</p> <p>Loosen the stepping motor screws (2EA), and then Release the stepping motor.</p>	<p>Loosen the control Box screw</p>	

Procedure

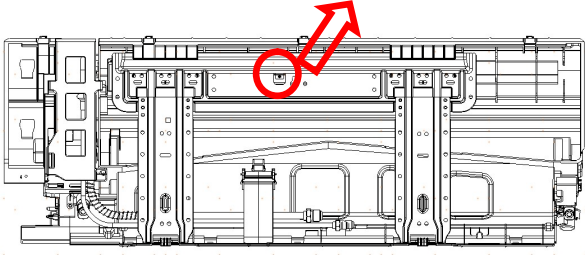
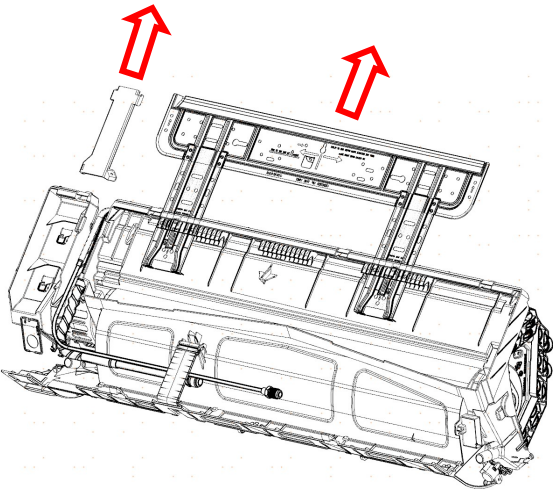
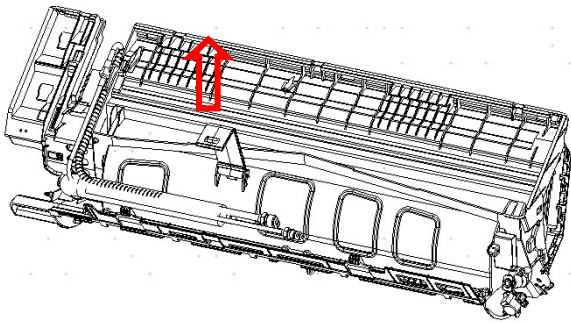

Warning Be sure to wait 10 minutes or more after turning off all power supplies before disassembling work.

Step	Procedure	Points
7. Removal of Heat Exchanger		
1	<p>Loosen the marked screws(1EA).</p> 	
2	<p>Pull mounting plate and heat exchanger bracket out from Hook of the base frame and then release them. Release the fixture plate from the base Frame hook and remove it.</p>  	

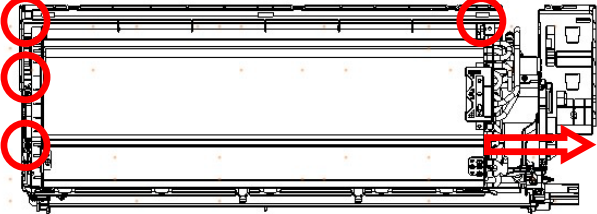
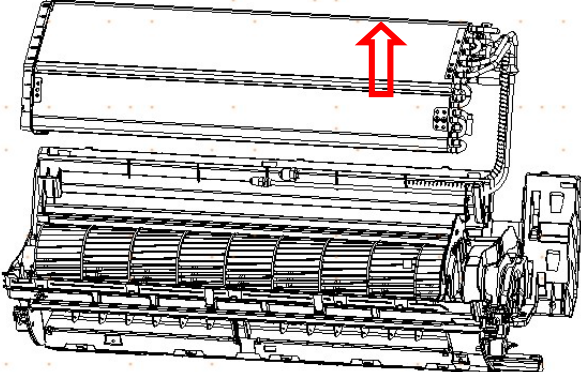
Step		Procedure	Points
3	Loosen the marked screws(5EA),contains 1 screws on the right side		
4	Loosen the marked screws (4EA). And then Remove the heat exchanger		

Procedure



Warning Be sure to wait 10 minutes or more after turning off all power supplies before disassembling work.

Step	Procedure	Points
8. Remove Fan Motor		
1	Loosen the marked screws(4EA) and release the cover of fan motor.	
2	Loosen the marked screw (2EA) of fan motor up bracket and remove it.	

Step	Procedure	Points
3	Loosen the marked screw (1EA) of fan motor and remove fan motor.	
4	Lift up the right part of the fan and remove it.	

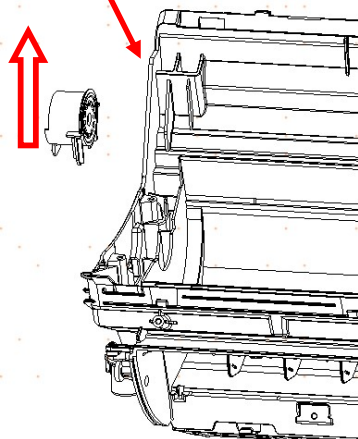
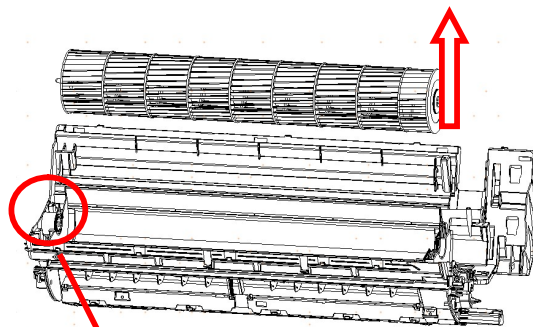
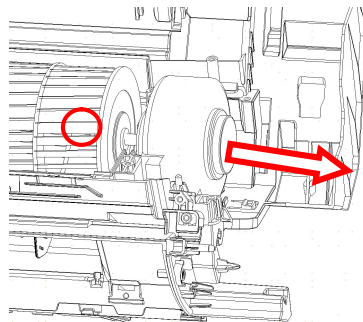
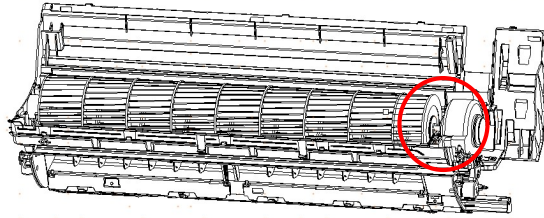

Procedure



Warning Be sure to wait 10 minutes or more after turning off all power supplies before disassembling work.

Step	Procedure	Points
<p>8. Remove fan motor bracket and fan bearing</p>		
1	<p>Pull the hook of fan motor bracket and upward remove it.</p>	
2	<p>Pull the hook of bearing bracket and upward remove it.</p>	

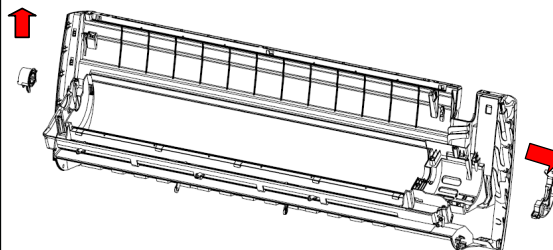
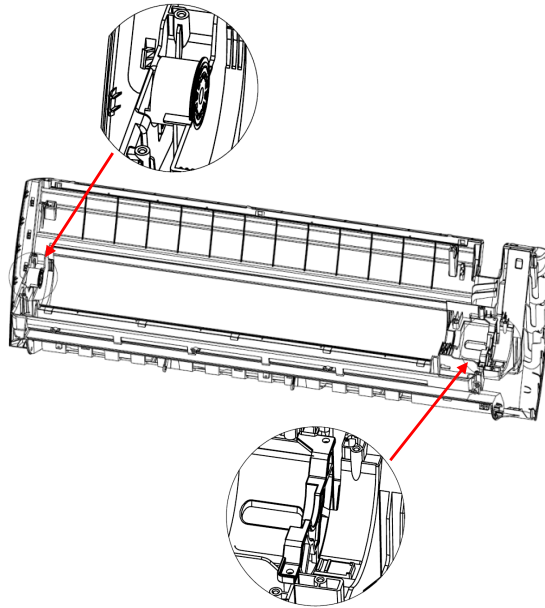

Haier

Operation Manual Inverter Split Air Conditioner

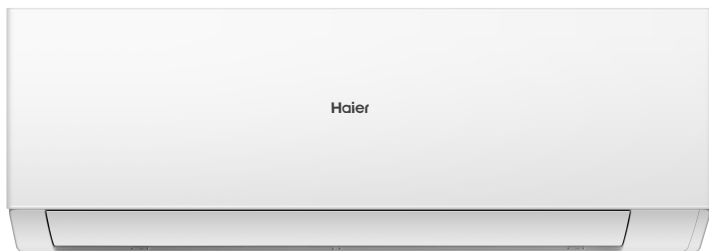

AS71PEGHRA
AS85PFGHRA



AF50DBAHRA

Please read this operation manual before using the air conditioner.

Keep this operation manual for future reference. This appliance is filled with R32.

00105113628



Contents

Warning	1
Features	2
Parts and Functions.....	4
Operation	5
Maintenance	11
Cautions	12

Warning

This appliance contains a UVC lamp.

- Read the maintenance instructions before operating the appliance.
- Exposure to the top air inlet and inner part may cause eye or skin irritation. When performing maintenance tasks such as taking out or replacing the air filter, ensure that the power is switched off before approaching the product.
- The UVC barriers, marked with the ultraviolet radiation hazard symbol, must not be removed.
- Appliances that are obviously damaged must not be operated.
- Do not operate UVC lamps outside of the appliance.
- The appliance must be disconnected from the power supply before replacing or cleaning or other maintenance of the UVC lamp.
- The type of UV-C lamp is 0011022283A, for AF50DBAHRA, it's 0011044338.
- The front panels, marked with the ultraviolet radiation hazard symbol and containing UVC radiation, are equipped with a switch to deactivate the power to the UVC lamps for safety purposes. Do not attempt to override the switch using magnets or similar materials.
- Prior to opening front panels marked with the ultraviolet radiation hazard symbol for user maintenance, it is advisable to disconnect the power source.
- To prevent any hazard, if the UVC lamp is damaged, it should be replaced by the manufacturer, its service agent, or similarly qualified individuals.
- Unintended use of the appliance or damage to the housing may result in the escape of dangerous UVC radiation. UVC radiation may, even in small doses, cause harm to the eyes and skin.
- Misuse of the appliance or damage to its housing may lead to the release of hazardous UVC radiation. Even in small amounts, UVC radiation can cause harm to the eyes and skin.

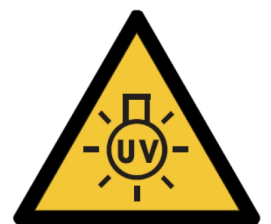

Features



Coanda Plus Airflow



Further, Faster, Stronger Cools Every Corner of the Room

Makes the wind out of the air conditioner further, faster, and stronger, so that the cool air can be evenly delivered to every corner of the room.

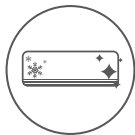

Self-Clean



Always Clean Always Cool

Freezing the evaporator and condenser with moisture in the air, and rapidly melting away dirt ensures that the air coming out of the air conditioner is always healthy for you.



UVC Pro Sterilization



Improved Purity Improved Living

Haier UVC Pro inhibits bacteria and viruses in the air, purifies the air by emitting UV-C band ray and generating positive and negative ions group.

Features



COMFORTABLE
AIRFLOW

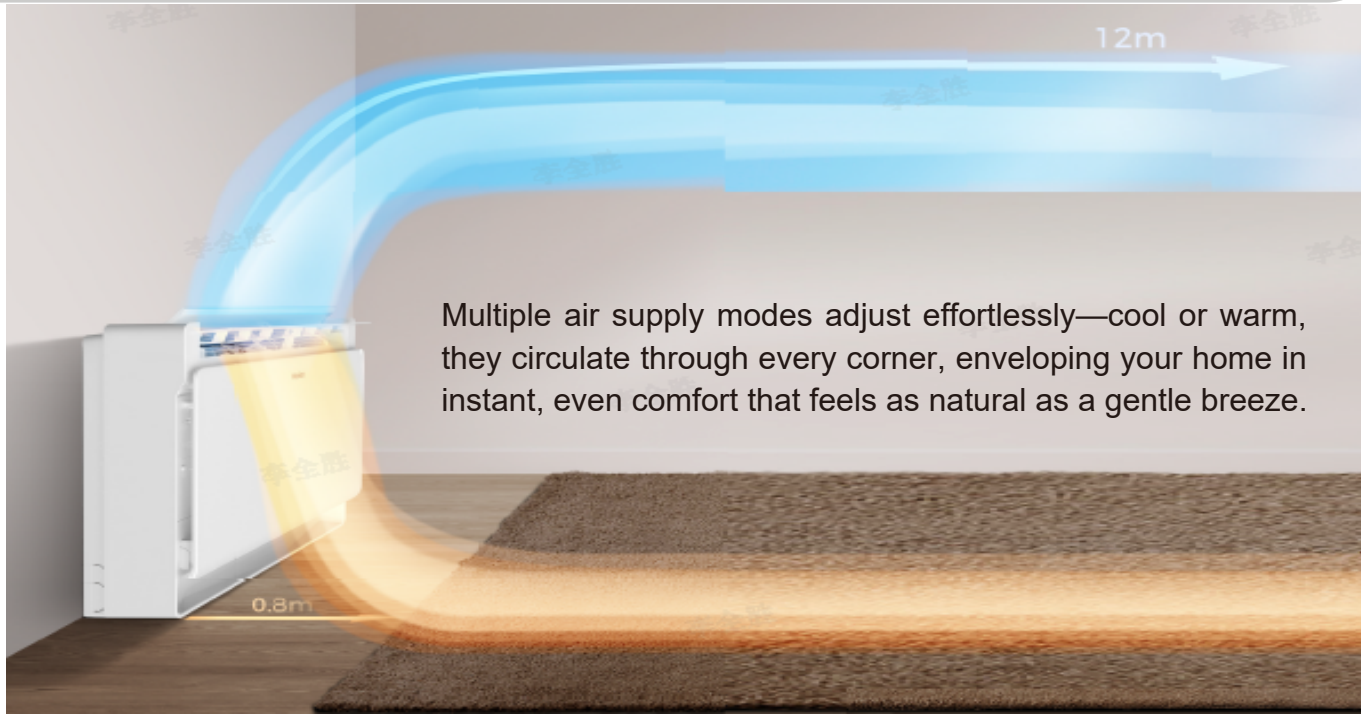

Multiple air supply modes adjust effortlessly—cool or warm, they circulate through every corner, enveloping your home in instant, even comfort that feels as natural as a gentle breeze.



SELF-CLEAN

Freezes the evaporator with moisture in the air, and removes away dirt in rapid melting, ensuring the air that comes out of air conditioners is always healthy for you.

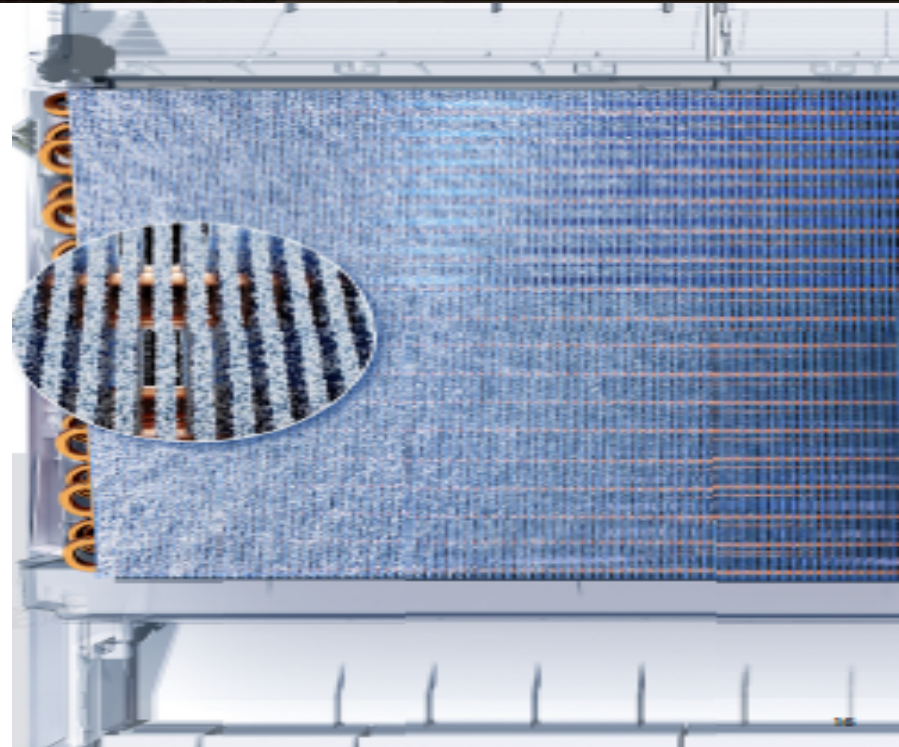

UVC PLUS
STERILIZATION



Haier UVC Plus effectively enhances air quality by generating hydroxyl radicals(OH•) and reactive oxygen species to oxidize and decompose harmful organic compounds, such as odors, and using UVC to sterilize indoor air near the air inlet.

Parts and Functions

Indoor Unit

AS71PEGHRA
AS85PFGHRA

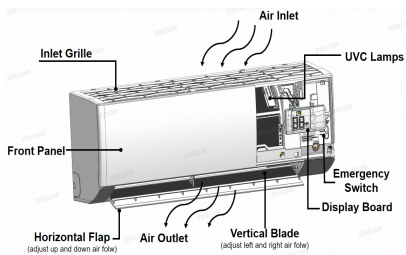

AF50DBAHRA

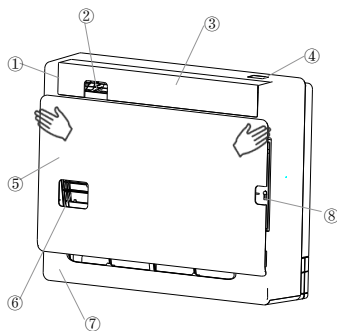

Display board

- 1 Signal receiver
- 2 Setting temp. display
- 3 Operation mode indicator
- 4 Wi-Fi



Display board

- 1. Wi-Fi
- 2. Setting temp. display



- 1. Outlet
- 2. Vertical blade (adjust left and right airflow)
- 3. Horizontal flap (adjust up and down air flow. Don't adjust it manually)
- 4. Display board (inside)
- 5. Inlet grille
- 6. Air Purifying Filter (inside)
- 7. Inlet
- 8. ON/OFF Button

Indicator lamp colour	Operation mode
Blue	COOL/DRY
Peach	HEAT
Cyan	HEALTH
No	FAN

Actual inlet grille may vary from the one shown in the manual according to the product purchased.

Outdoor Unit

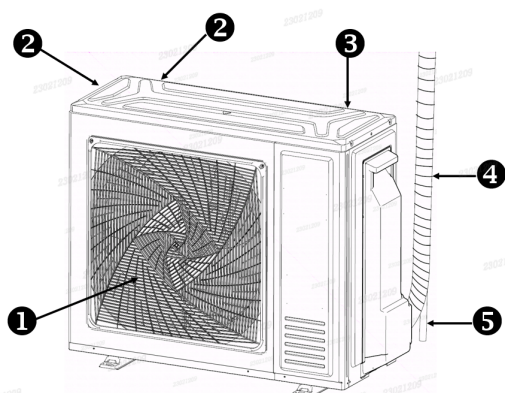

- 1 Air Outlet
- 2 Air Inlet
- 3 Outdoor temperature sensor
- 4 Connecting Piping and Electrical Wiring
- 5 Drain Hose

The outdoor unit may vary depending on the specific product purchased. The image above is provided for reference purposes.

Remote Controller

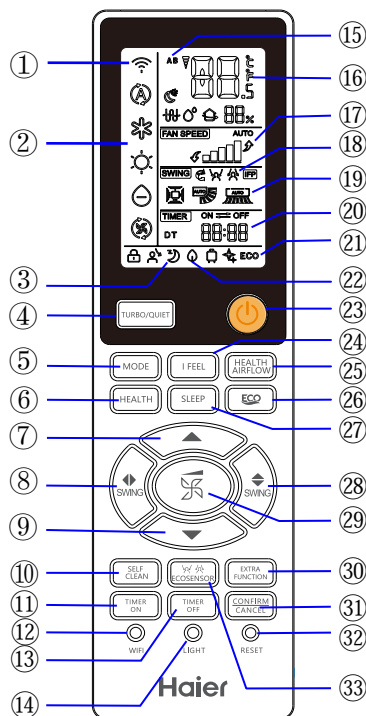

- 1. Signal display
- 2. Mode display
- 3. Sleeping display
- 4. TURBO/QUIET button
- 5. MODE button
Function: AUTO → COOL → HEAT → DRY → FAN
- 6. HEALTH button (UVC starts working)
- 7. TEMP "+" button
- 8. SWING LEFT/RIGHT button
- 9. TEMP "-" button

- 10. SELF CLEAN button
- 11. TIMER ON button
- 12. WIFI button
- 13. TIMER OFF button
- 14. LIGHT button
- 15. A/B yard
- 16. TEMP display
- 17. Fan Speed display
- 18. Sensor display
- 19. Swing display:
SWING UP/DOWN display
SWING LEFT/RIGHT display
- 20. Timing display:
TIMER ON/OFF display
CLOCK display
- 21. ECO display
- 22. Health display
- 23. POWER ON/OFF button
- 24. IFEEL button
- 25. HEALTH AIRFLOW button
- 26. ECO button
- 27. SLEEP button
- 28. SWING UP/DOWN button
- 29. FAN SPEED button
- 30. EXTRA FUNCTION button

Function: A/B yard → 10°C
Heating (in HEATING mode)
→ F/C switch
→ CH (in COOLING mode)

- 31. CONFIRM CANCEL button
- 32. RESET button
- 33. ECO-SENSOR button

Notes: This ECO-SENSOR is unavailable on some models.

NOTE: During HEAT mode, warm air will begin to blow out after a brief delay, thanks to the cold-draft prevention function. The duration of this delay is determined by the ambient temperature.

Remote Controller

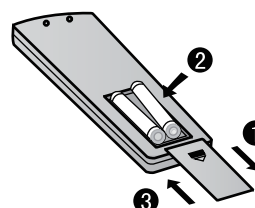

- 1 Remove the battery cover.
- 2 Load the batteries as illustrated. 2 AAA batteries, resetting key (cylinder).
- 3 Be sure that the loading is in line with the "+" / "-" .
- 4 Load the battery, then put on the cover again.

• To reset the unit, follow these steps:

- Turn off the unit.
- Press the reset button on the remote. The screen will display multiple icons before returning to a blank screen with the time flashing as 12:00.
- Use the up/down buttons to adjust the time.
- Once the correct time is set, press the confirm/cancel button on the remote.

• Ensure that the distance between the signal transmission head and the receiver hole is within 7m without any obstacles. If electronic devices like fluorescent lamps or wireless telephones are present in the room, keep the distance shorter.

• If the display appears incomplete or unclear during operation, it indicates that the batteries are depleted. Replace the batteries.

• If the remote controller malfunctions during operation, remove the batteries and wait several minutes before reinstalling them.

Operation

Unit Start/Stop

Remote controller

1. Unit start

Press ON/OFF on the remote controller, unit starts.

2. Select operation mode

COOL : Refrigeration mode
HEAT : Heating mode
DRY : Dehumidification mode
FAN : Air supply mode
AUTO: Automatic mode

3. Select temp. setting

Press ▲ / ▼ button

▲ Every time the button is pressed, temp. setting increase 1°C, if kept depressed, it will increase rapidly.

▼ Every time the button is pressed, temp. setting decrease 1°C, if kept depressed, it will decrease rapidly.

Select a desired temperature.



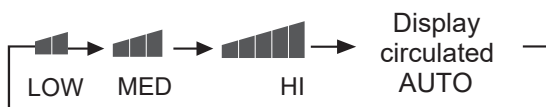

4. Fan speed selection

Press  button. For each press, fan speed changes as follows:

Remote controller:



The air conditioner operates at the displayed fan speed. When the FAN mode is set to AUTO, the air conditioner automatically adjusts the fan speed based on the room temperature.

Operation Mode	Remote Controller	Note
AUTO		Under the mode of auto operation, air conditioner will automatically select Cool or Heat operation according to room temperature. When FAN is set to AUTO, the air conditioner automatically adjusts the fan speed according to room temperature.
COOL		Cooling only unit do not have displays and functions related with heating.
DRY		In DRY mode, if the room temperature drops below the temperature setting by 2°C, the unit will intermittently run at LOW speed, regardless of the FAN setting.
HEAT		In HEAT mode, warm air will begin to blow out after a short delay due to the cold-draft prevention function.
FAN		In FAN operation mode, the unit operates solely in FAN mode, without COOL or HEAT functions. AUTO mode is unavailable in FAN mode, and temperature setting is disabled. Additionally, SLEEP operation is not available in FAN mode.

Air Flow Direction Adjustment

1. Up and down air flow direction

For each press of SWING  button, the air flow direction on the remote controller displays as follows according to different operation modes:

COOL/DRY/FAN: 

AUTO: 

HEAT: 

2. Left and right air flow adjustment

For each press of SWING  button, remote controller displays as follows:
remote controller:



CAUTIONS:

- Always turn off the unit before adjusting the flap by hand.
- In conditions of high humidity, condensate water may accumulate at the air outlet if all vertical louvers are adjusted to the left or right.
- Avoid keeping the horizontal flap in a downward position for extended periods in COOL or DRY mode, as this may lead to condensate water formation. Upon restarting after remote turning off, the remote controller will automatically return to the previously set swing position.
- When healthy airflow function is set, the up and down air flow adjustment function can't be set up.

TURBO/QUIET Operation

1. TURBO Operation

When you require rapid heating or cooling, you can activate the TURBO function. Press the TURBO/QUIET button, and the remote controller will indicate the activation of the TURBO function . Pressing the TURBO/QUIET button again will deactivate the TURBO function.

2. QUIET Operation

When silence is required for rest or reading, you can utilize the QUIET function. Press the TURBO/QUIET button, and the remote controller will indicate the activation of the QUIET function . Pressing the TURBO/QUIET button again will cancel the QUIET function.

For each press, the function changes as follows:

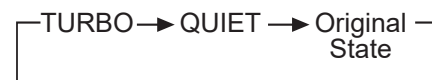









NOTE:

- During POWER operation, in rapid COOL mode, the room may exhibit an inhomogeneous temperature distribution.
- Prolonged QUIET operation may result in a less pronounced cooling or warming effect.

Operation

Timer On/Off On-Off Operation

1. After unit starts, select your desired operation mode.
2. Press  /  button to change **TIMER**.
 Press  button "TIMER ON" will appear, after 10 seconds the time display will be blank.
 Press  button "TIMER OFF" will appear, after 10 seconds the time display will be blank.
 Then select your desired TIMER mode (TIMER ON or TIMER OFF). "ON" or "OFF" will flash.
3. Press  /  button to set time.
 Each press will increase or decrease the time by 1 minute. If the button is held down, the time will change rapidly.
4. Confirm timer setting.
 After adjust the time, press  to confirm, and the time ON or OFF button will stop flashing.
5. Cancel timer setting.
 Press the  button to eliminate the time display.

NOTE:

- After replacing batteries or experiencing a power failure, the time setting needs to be reset.
- Following the time setting sequence for "TIME ON" or "TIME OFF," you can achieve either a Start-Stop or Stop-Start function.

SELF-CLEAN Operation

FUNCTIONAL DESCRIPTION: The purpose of this function is to clean the **evaporator** and **condenser**.

TECHNOLOGY: Dirt tends to accumulate on the evaporator during operation. If not cleaned regularly, this accumulation can lead to the growth of mold and bacteria, which can compromise the air quality provided by the air conditioner. Moreover, it can reduce the efficiency of the air conditioning system by **15-30%**.

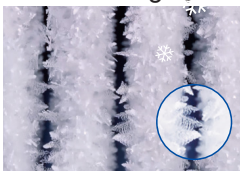

Cold Expansion

Occurs when frost forms on the evaporator/condenser, generating a strong force that can effectively peel off dirt from the surface.

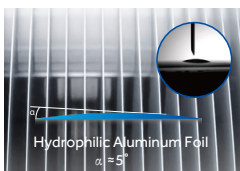

Express Washing

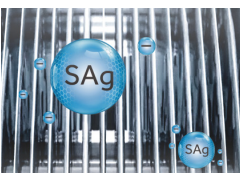

Hydrophilic aluminum with a smaller angle enhances water drainage efficiency by 20%.



Anti-bacteria

The coating on the aluminum contains silver nanoparticles that efficiently eliminate bacteria and inhibit their growth with over 99.99% effectiveness.

SELF-CLEAN Operation

ENTRY and EXIT: To activate this function, press  button. "CL" will be displayed on both the panel of the indoor unit and the remote controller. After running for 20-30 minutes, the function will exit automatically, indicated by two "Pi" sounds. The unit will return to its original state. During the process, pressing the button repeatedly will have no effect, and the function will not exit. However, pressing the "POWER"  button or switching to another mode can exit the self-cleaning function.

NOTE:

1. This function is not available in TIMER/SLEEP/HEAT mode.
2. After activating this mode, the air volume may decrease or even stop altogether, and cold airflow may occur.
3. It's normal for the unit to make sounds like expanding with heat and contracting with cold.
4. If the outside ambient temperature drops below zero, error code "F25" may occur during self-cleaning operation. This is a normal protective measure. Please turn off the power and restart after 10 seconds.
5. The optimal conditions to run this mode are: indoor temp. between 20°C and 27°C, indoor humidity between 35% and 60%, and outdoor temp. between 25°C and 38°C during the cooling season.
6. It's difficult for frost to form if the air is too dry (humidity < 20%). Conversely, if the humidity is too high (humidity > 70%), condensate water may increase and remove some frost.

DRED Operation

Haier Peak smart enabled air-conditioners have a Demand Response Mode display on the indoor unit. The display could be labelled d1, d2, d3 (wording may differ model to model).

These modes are described in more detail below:



Mode	Display	Description	What to do
DRM3	d3	Your air-conditioner will continue to cool or heat during the peak demand event. The energy consumed by your air-conditioner is capped at 75%.	No action is required.
DRM2	d2	Your air-conditioner will continue to cool or heat during the peak demand event. The energy consumed by your air conditioner is capped at 50%.	No action is required.
DRM1	d1	Your air conditioner is still turned on, and the fan will continue to operate. However, the compressor is turned off, and cool/hot air will no longer be generated.	DRM1 mode is only activated during emergency demand management situations. This mode will automatically reset the device within 2 hours.

NOTE:

When the self-cleaning is in operation, it will exit the self-cleaning mode upon entering DRED mode. When the DRED function is set, the self-cleaning function cannot be activated.

Operation

Comfortable SLEEP

Press the  button, and the remote controller will activate the sleep function by displaying .

Pressing  again will cancel the sleep function.



Operation Mode

1. In COOL/DRY mode

1 hour after SLEEP mode starts, the temperature will increase by 1°C compared to the temperature setting. After another hour, the temperature will rise by an additional 1°C. The unit will continue to run for an additional 6 hours before stopping. This prevents the room temperature from becoming too low during your sleep.

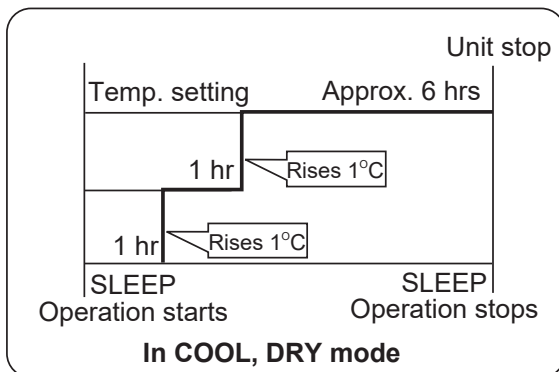

2. In HEAT mode

1 hours after SLEEP mode starts, temp will become 2°C lower than temp. setting. After another 1 hours, temp. decrease by 2°C further. After more another 3 hours, temp. rises by 1°C further. The unit will run for further 3 hours then stops. Temp. is lower than temp. setting so that room temperature won't be too high for your sleep.

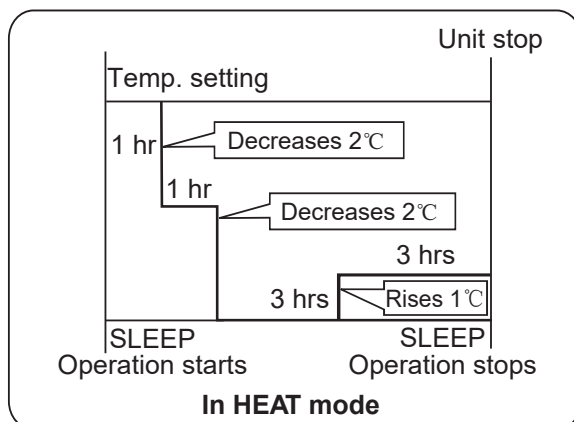

Comfortable SLEEP

3. In AUTO mode

The unit operates in the corresponding sleep mode adapted to the automatically selected operation mode.

4. In FAN mode

The unit does not have a SLEEP function.

5. When the quiet sleeping function is set to 8 hours, the quiet sleeping time cannot be adjusted.

6. Set the wind speed change when sleeping:

- If the wind speed is high or medium before setting for sleep, adjust it to low wind speed after sleeping.
- If it is already set to low wind speed, no change will occur.

NOTE:

When the TIMER function is set, the sleeping function cannot be activated.



- If the sleeping function is set up and the user resets the TIMER function, the sleeping function will be canceled, and the unit will be in the timing-on state.



- If both modes are set up simultaneously, and either of their operation times ends first, the unit will stop automatically, and the other mode will be canceled.



Healthy Airflow Operation

1. Press  to start and set the comfort working conditions.

2. The setting of the healthy airflow function:

1) Press ,  appears on the display to prevent strong airflow from directly blowing onto the body.

2) Press ,  appears on the display to avoid strong airflow from directly blowing onto the body.

3) Press ,  appears on the display to avoid strong airflow from directly blowing onto the body.

Function 1) and 2) are applicable to AS71PEGHRA and AS85PFGHRA; Function 3) is applicable to AF50DBAHR.

3. Cancelling the Healthy Airflow Function

Press  again, Both the inlet and outlet grills of the air conditioner will open, and the unit will continue operating under the previous airflow function setting. After stopping, the outlet grille will automatically close.

NOTE:

▲ Avoid manually adjusting the flap, as it may cause the grille to operate incorrectly. If the grille is not functioning properly, stop it for a minute and then restart, adjusting using the remote controller.

▲ In heating mode, it is preferable to select  mode.



▲ In cooling mode, it is preferable to select  mode.

▲ In cooling and dry mode, if the air conditioner is used for an extended period under high humidity, condensate water may occur at the grille.

▲ When the function is activated, left and right functions can be set, while up and down will not.

Operation

HEALTH Operation

Press the  button, and the remote controller will display "  " to activate the health function. To cancel the function, simply press the  button again.



TECHNOLOGY:

Haier UVC utilises UVC-band rays at the air inlet. Direct exposure to these rays destroys the DNA and RNA structure of bacteria and viruses in the air as it passes through the air inlet. Additionally, UVC can stimulate H₂O nano and O₂ in the air, generating positive and negative ion groups that purify the air.

NOTE:

1. It is advisable to activate the UV sterilization function for 1-2 hours per day. Prolonged use may impact the lifespan of the UVC lamp.
2. Avoid direct exposure to the UVC lamp or touching it when the sterilizing function is active. Remember to turn off the sterilizing function before opening the panel.
3. A tinged blue light may be visible near the air conditioning inlet when the sterilizing function is activated.
4. The UVC lamp will only be illuminated when the internal fan starts and the health function is turned on.

IFEEL Operation

1. This function is available only in cooling, heating, or auto mode (other modes cannot be implemented).
2. Position the remote controller within the acceptable range of the air conditioner. Press the  button, and the remote control will display . The remote controller sends the circulation temperature data to the indoor unit every 3 minutes, and the air conditioner operates according to this data.
3. "IFEEL" mode can be exited by turning off the power, pressing the  button again, or switching to other modes.

Comfortable Experience

This function optimises the working conditions of the air conditioner to deliver airflow at the best temperature for your comfort.

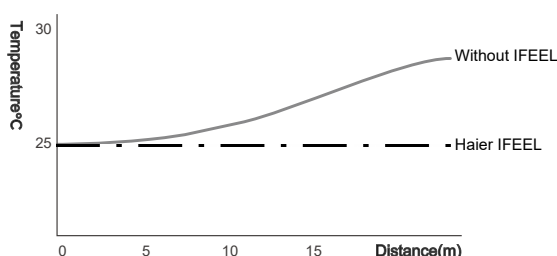

ECO Operation

The 3-Level-ECO function is an active energy-saving function, which can be activated by pressing the  button. The remote controller displays the energy-saving symbol "ECO". The cycle goes as: L1→L2→L3→exit.



- Press the ECO button once to enter L1 mode.
- Press the ECO button again in L1 mode to enter L2 mode.
- Press the ECO button again in L2 mode to enter L3 mode.
- Continue to press the ECO button in L3 mode to exit this function. • After each press of the  button, the remote controller screen and air conditioning panel display L1/L2/L3 respectively for five seconds, and then return to the previous display.
- The maximum energy-saving rate is 50%.

NOTE:

1. The indoor unit fan speed will be adjusted according to energy-saving logic after entering the ECO function.
2. Capacity may decrease when ECO function is selected. If this function does not meet your requirement, please exit the function.
3. The energy-saving effect will be weakened when the outdoor ambient temperature is too low or too high.
4. The energy-saving rate is from laboratory comparison data between normal running in high wind speed without the 3-Level-ECO function selected and running with this function selected.
5. The Energy Control mode can be set only when the device is powered on.

Anti-mildew Function Description

After refrigeration or dehumidification operation, the internal evaporator will retain moisture. The mildew-proof drying function can dry the moisture to prevent mold from producing odors.

Press the  button, until the remote controller displays the anti-mildew symbol "CH" and it is necessary to press the  button within 4 seconds. The internal unit operates at a silent speed, and the guide plate defaults to a healthy upward blowing position. After running for ten minutes, end the anti-mildew function and power off.

NOTE:

1. In the refrigeration or dehumidification mode, the active mildew prevention logic will be implemented immediately after setting the mildew prevention function, and the rest of the settings are invalid;
2. This function has no power loss memory and needs to be reset to enter when used again.
3. If the external machine is protected and shut down at this stage, the internal machine will continue to operate to prevent mildew, do not display the fault code, and will no longer send the press start signal to the external machine;
4. During the execution process, the shutdown signal or mode conversion signal is received, and the active anti-mildew is immediately terminated and run according to the remote control settings.

Operation

WIFI Function Description

If your Air Conditioner (AC) has a Connected Appliance Information label located under the front cover as shown below, your AC is WiFi Connect Enabled.

A WiFi communication card is built into the product allowing it to communicate with your smart phone for remote monitoring, control and notifications.

Please visit <https://www.haierhome.com.au> or <https://www.haierhome.co.nz> to learn more about connected appliance features, and to learn what connected appliance apps will work with your smart phone.

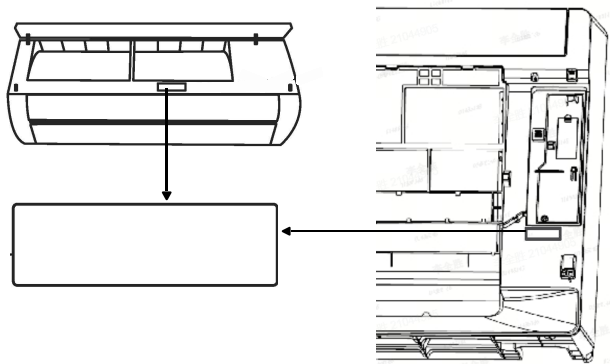

Application software installation:

— Application Requirements:

A smart mobile phone and a wireless router are necessary for the application. The wireless router must be capable of connecting to the Internet.

— Configuration method

Please scan the QR code below to download the "SmartHQ" app. Once downloaded, please register, connect the air conditioner, and enjoy using "SmartHQ" to manage your device.



Options of connecting conditioner to your smart phone

Please note: With the "Smart HQ" app installed on your phone and an app account registered.

- 1 Turn on your phone's Bluetooth.
- 2 Put the device into configuration mode: press and hold the power button or the WiFi button for 5 seconds, the remote control and machine display panel show "Cooling at 30°C" then the WiFi light on the display panel flashes the WiFi indicator light should flash on the device.
- 3 Open the "SmartHQ" app, click the plus sign in the upper right corner, and enter the device add page.
- 4 Select the device found under "NEARBY", click "Connect", and the first binding will prompt Bluetooth pairing.
- 5 Select the network that you want to connect to, enter the password of the network, and click "CONNECT".
- 6 Wait for the device to bind successfully, and click GET STARTED.
- 7 After the fifth step is completed, automatically jump to the home page of the App, select the successfully bound device for control.

WIFI Function Description

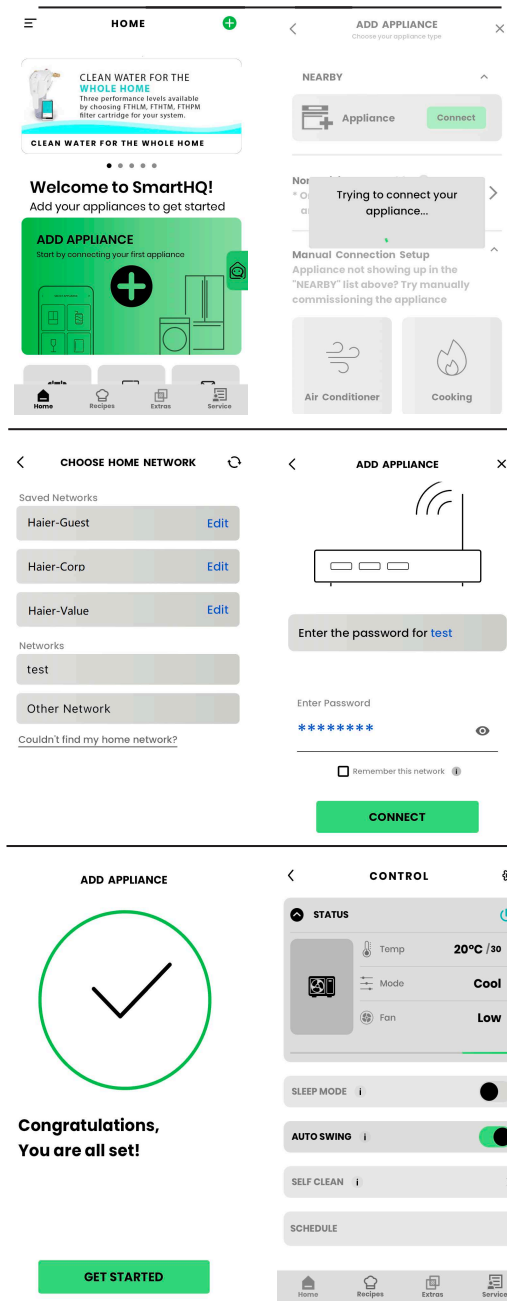

LIGHT BUTTON

Controlling the LED Display Board Light

When the air conditioner is operating, the LED display panel shows the set temperature.

• To turn off the LED display light, press the LIGHT button twice within 5 seconds. When the air conditioner receives a signal from the remote control, the display will light up and automatically turn off after 5 seconds.

• To turn the light back on while it is off, press the LIGHT button once.

The LED light-off setting is temporary and applies only during the current power-on cycle. It will reset to the factory default after the air conditioner is turned off or restarted following a power failure.

Operation

Emergency operation and Test operation

Emergency Operation:

- Use this operation only when the remote controller is defective or lost, and with the emergency running function, the air conditioner can operate automatically for a limited period.
- When the emergency operation switch is pressed, a single "Pi" sound is heard, indicating the start of this operation.
- Upon the initial power switch activation and the start of emergency operation, the unit will automatically operate in the following modes:

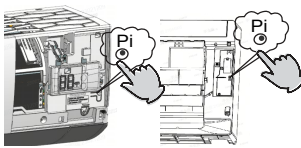

Room Temperature	Designated Temperature	Timer Mode	Fan Speed	Operation Mode
Above 23°C	26°C	No	AUTO	COOL
Below 23°C	23°C	No	AUTO	HEAT

- Operating in dry mode is not possible during emergency operation.

Test Operation:

- Test operation switch is the same as emergency switch. Use the switch for test operation only when the room temperature is below 16°C; do not use it during normal operation.
- To initiate the test operation, continue pressing the test operation switch for more than 5 seconds.
- After hearing the "Pi" sound twice, release your finger from the switch. The cooling operation will start with the air flow speed set to "Hi".
- The test operation will automatically end after 30 minutes.

WIFI BUTTON



Use the button to enter WIFI binding mode and it means your device is ready to connect.

NOTE: This function is unavailable on some models.

RESET BUTTON

If the remote control is not functioning properly, press this button to reset the remote.





10 °C HEATING Operation





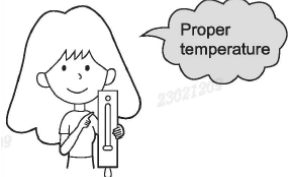
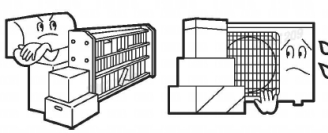

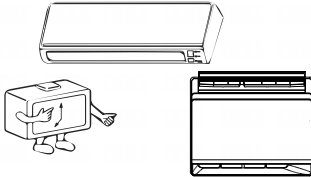
Press the  buttons, the remote controller displays the symbol "10°C" and it is necessary to press the  button within 4 seconds.

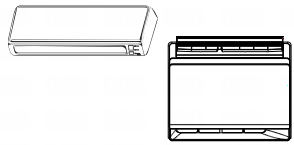
Allows you to preset your air conditioner to start automatically if the internal temperature drops below a preset temperature (adjustable between 10-16C) while your not at home. Ideal for use in locations that experience very cold conditions, this function can be instrumental in preventing the formation of dampness and mould.

Maintenance

For Smart Use of The Air Conditioner

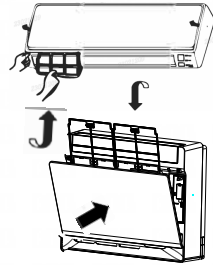
<p>Setting of proper room temperature.</p>  <p>Proper temperature</p>	<p>Do not block the air inlet or outlet.</p> 
<p>Close doors and windows during operation.</p>  <p>During cooling operation prevent the penetration of direct sunlight with curtain or blind</p>	<p>Use the timer effectively.</p> 
<p>If the unit is to remain unused for an extended period, switch off the main power supply.</p> 	<p>Use the louvers effectively.</p> 

<p>Remote Controller</p>  <p>Avoid using water; instead, wipe the controller with a dry cloth. Refrain from using glass cleaner or chemical cloths.</p>	<p>Indoor Body</p>  <p>Wipe the air conditioner by using a soft and dry cloth. For serious stains, use a neutral detergent diluted with water. Wring the water out of the cloth before wiping, then wipe off the detergent completely.</p>
<p>Do not use the following for cleaning</p>  <p>Gasoline, benzene, thinner or cleanser may damage the coating of the unit.</p>  <p>Hot water over 40°C(104°F) may cause discoloring or deformation.</p>	
<p>Air Filter cleaning</p> <ol style="list-style-type: none"> 1 Pull the inlet grille upward to open it. 2 Remove the filter. Gently push up the center tab of the filter until it releases from the stopper, then pull the filter downward to remove it. 3 Clean the filter. Utilise a vacuum cleaner to eliminate dust, or wash the filter with water. After washing, thoroughly dry the filter in a shaded area. 4 Attach the filter. Ensure proper attachment of the filter with the "FRONT" indication facing forward. Confirm that the filter is securely fixed behind the stopper. Incorrect attachment of the right and left filters may lead to defects. 5 Close the inlet grille. 	
<p>Once every two weeks</p> 	

Replacement of Air Purifying Filter (NOTE: Air purifying filter is optional part)

- 1. Open the Inlet Grille**
Prop up the inlet grille by using a small device named grille-support which located in the right side of the indoor unit.

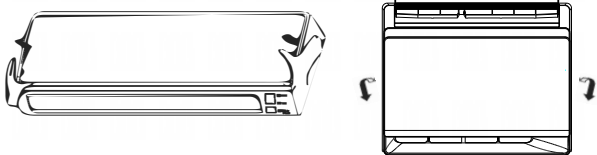
- 2. Detach the standard air filter** Gently slide the knob upward to release it, then withdraw the filter.

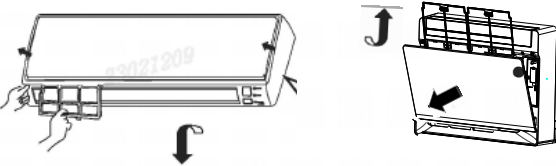
- 3. Attach Air Purifying Filter**
Put air purifying filter appliances into the right and left filter frames.

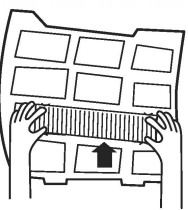

- 4. Attach the standard air filter (Necessary installation)**



ATTENTION:
Ensure the white side of the photocatalyst air purifying filter faces outward, while the black side faces the unit. Similarly, position the green side of the bacteria-killing medium air purifying filter outward, with the white side facing the unit.
- 5. Close the Inlet Grille**
Securely close the grille.

NOTE:

 - The photocatalyst air purifying filter will undergo solarization at regular intervals. In a typical household, this process occurs every 6 months.
 - To maintain the effectiveness of the bacteria-killing medium air purifying filter, store it in cool, dry conditions, away from prolonged exposure to direct sunlight when not in use. This helps prevent a reduction in its sterilization capabilities.

Cautions

⚠ WARNING

For installation, please contact Sales/Service Shop. Do not attempt to install the air conditioner yourself, as improper installation may result in electric shock, fire, or water leakage.

⚠ WARNING

If you notice any abnormalities such as a burnt smell, promptly cease operation by pressing the button and contact the sales shop for assistance.

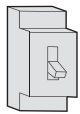

OFF



!
STRICT ENFORCEMENT

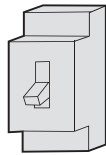

Use an exclusive power source with a circuit break.

!
STRICT ENFORCEMENT

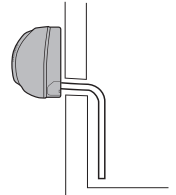

Check proper installation of the drainage.

1. Avoid using power supply cords that are extended or connected halfway.
2. Avoid installing the unit in areas where there is a risk of inflammable gas leakage.
3. Additionally, prevent exposure of
4. the unit to vapor or oil steam. **PROHIBITION**



Avoid inserting objects into the air inlet or outlet.

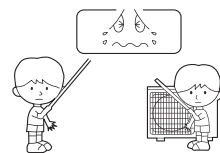

PROHIBITION

Do not start or stop the operation by disconnecting the power supply cord or similar methods.



PROHIBITION

Avoid directing the airflow directly at people, especially infants or the elderly.

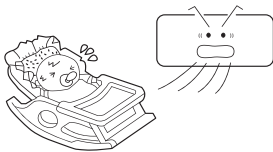

Do not attempt to repair or modify the unit by yourself.

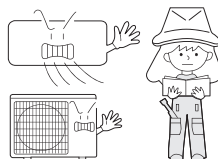

Connect the earth cable.

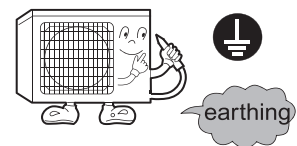

⚠ CAUTION

Do not use for storing food, artwork, precision equipment, breeding, or cultivation purposes.



PROHIBITION

Occasionally, ensure to take in fresh air, especially when a gas appliance is running simultaneously.

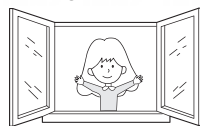

!
STRICT ENFORCEMENT

Avoid operating the switch with wet hands.

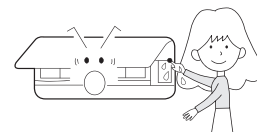

PROHIBITION

Do not install the unit near a fireplace or other heating apparatus.

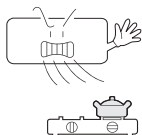

PROHIBITION

Check good condition of the installation stand

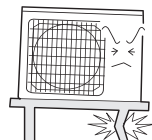

PROHIBITION

Do not pour water onto the unit for cleaning

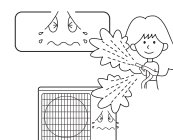

PROHIBITION

Avoid placing animals or plants directly in the path of the airflow.

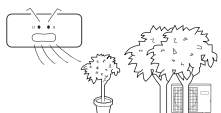

PROHIBITION

Do not place any objects on the unit or climb on it.





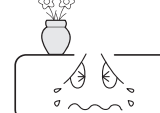

PROHIBITION

Avoid placing flower vases or water containers on top of the unit.



PROHIBITION

Cautions

Trouble Shooting		
Item	Phenomenon	Cause or check points
	The system does not restart immediately. 	<ul style="list-style-type: none"> After the unit is stopped, it will not immediately restart to protect the system; a 3-minute delay is required. When the electric plug is removed and reinserted, the protection circuit will activate for 3 minutes to safeguard the air conditioner.
	Noise is heard. 	<ul style="list-style-type: none"> During unit operation or at stop, a swishing or gurgling noise may be heard. At first 2-3 minutes after unit start, this noise is more noticeable. (This noise is generated by refrigerant flowing in the system.) During unit operation, a cracking noise may be heard. The noise is generated by the casing expanding or shrinking because of temperature changes. Should there be a big noise from air flow in unit operation, air filter may be too dirty.
	Smells generated.	<ul style="list-style-type: none"> This occurs because the system circulates odors from the indoor air, such as those from furniture, paint, or cigarettes.
	Mist or steam are blow out. 	<ul style="list-style-type: none"> During COOL or DRY operation, the indoor unit may emit mist. This is caused by the rapid cooling of indoor air.
	In DRY mode, fan speed can't be changed.	<ul style="list-style-type: none"> In DRY mode, when the room temperature drops below the set temperature by 2°C, the unit will intermittently operate at LOW speed, irrespective of the FAN setting.
		<ul style="list-style-type: none"> Is power plug inserted? Is there a power failure? Is fuse blown out?
		<p>Is the air filter dirty?-Normally it should be cleaned every 15 days.</p> <p>Are there any obstacles before inlet and outlet?</p> <p>Is temperature set correctly?</p> <p>Are there some doors or windows left open?</p> <p>Is there any direct sunlight through the window during the cooling operation? (Use curtain)</p> <p>Are there too much heat sources or too many people in the room during cooling operation?</p>

Cautions

- Avoid obstructing or covering the ventilation of the air conditioner. Do not insert fingers into the inlet/outlet or the swing louver.
- This appliance is not intended for use by individuals (including children) with reduced physical, sensory, or mental capabilities, or lack of experience and knowledge, unless they have been given supervision or instruction on how to use the appliance by a person responsible for their safety. Children should be supervised to ensure they do not play with the appliance.

Specifications

- The refrigerating circuit is leak-proof.

The machine is adaptive in following situation

- Applicable ambient temperature range:

Cooling	Indoor	Maximum:D.B/W.B 32°C/23°C Minimum :D.B/W.B 21°C/15°C
	Outdoor	Maximum:D.B/W.B 46°C/26°C Minimum :D.B/W.B -10°C
Heating	Indoor	Maximum:D.B/W.B 27°C Minimum :D.B/W.B 15°C
	Outdoor	Maximum:D.B/W.B 24°C/18°C Minimum :D.B/W.B -10°C
	Outdoor (INVERTER)	Maximum:D.B/W.B 24°C/18°C Minimum :D.B/W.B -15°C

- If the power supply cord is damaged, it must be replaced by the manufacturer or its service agent or a similar qualified person.
- If the fuse of indoor unit on PC board is broken, please change it with the type of T.3.15A/ 250V. If the fuse of outdoor unit is broken, change it with the type of T.25A/250V.
- The wiring method should be in line with the local wiring standard.
- After installation, the power plug should be easily reached.
- The waste battery should be disposed of properly.
- The appliance is not intended for use by young children or infirm persons without supervision.
- Young children should be supervised to ensure that they do not play with the appliance.
- Please use the appropriate power plug that fits into the power supply cord.
- The power plug and connecting cable must have acquired the local attestation.
- To protect the units, please turn off the A/C first, and then wait at least 30 seconds before cutting off the power.

Customer Care

Visit the website for more information

Australia: haierhome.com.au

New Zealand: haierhome.co.nz

Customer support and service booking Australia: 1300 729 948

New Zealand: 0800 424 372

Important notice of Disclosure: Copyright © Fisher & Paykel Appliances 2024. All rights reserved. The product dimensions and specifications in this document apply to the specific products and models described at the date of issue. Under our policy of continuous product improvement, these dimensions and specifications may change at any time. You should therefore check with your dealer or Haier's Customer Care Centre to ensure this flyer correctly describes the products currently available.

Fisher & Paykel Appliances Australia Level 1, 1 Eden Park Drive, Macquarie Park, NSW 2113.
New Zealand: Fisher & Paykel Appliances Ltd, 78 Springs Road, East Tamaki, Auckland 2013.

Haier

2. OUTDOOR UNIT

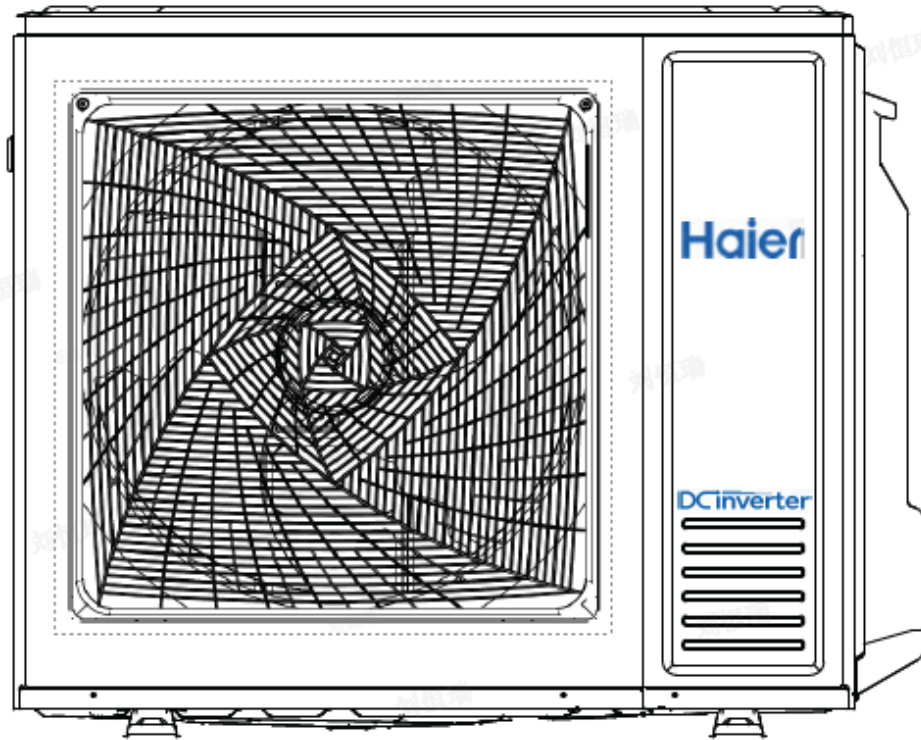

Model No.

1U71XAGFRA

AAD6N0E00

Contents

2.OUTDOOR UNIT

1. Introduction	1
2. Specifications.....	2
3.Sensors list	5
4.Piping diagrams	6
5.Operation range	7
6.Printed Circuit Board Connector Wiring Diagram	8
7. Functions and Control.....	11
8. Dimensional drawings.....	25
9. Conter of gravity	25
10.Service Diagnosis	26
11. Performance and cerves diagrams.....	48
12.Wiring Diagrams	56
13.Removal of procedure.....	57
14.Installation Manual.....	66

1 Introduction

Model name explanation

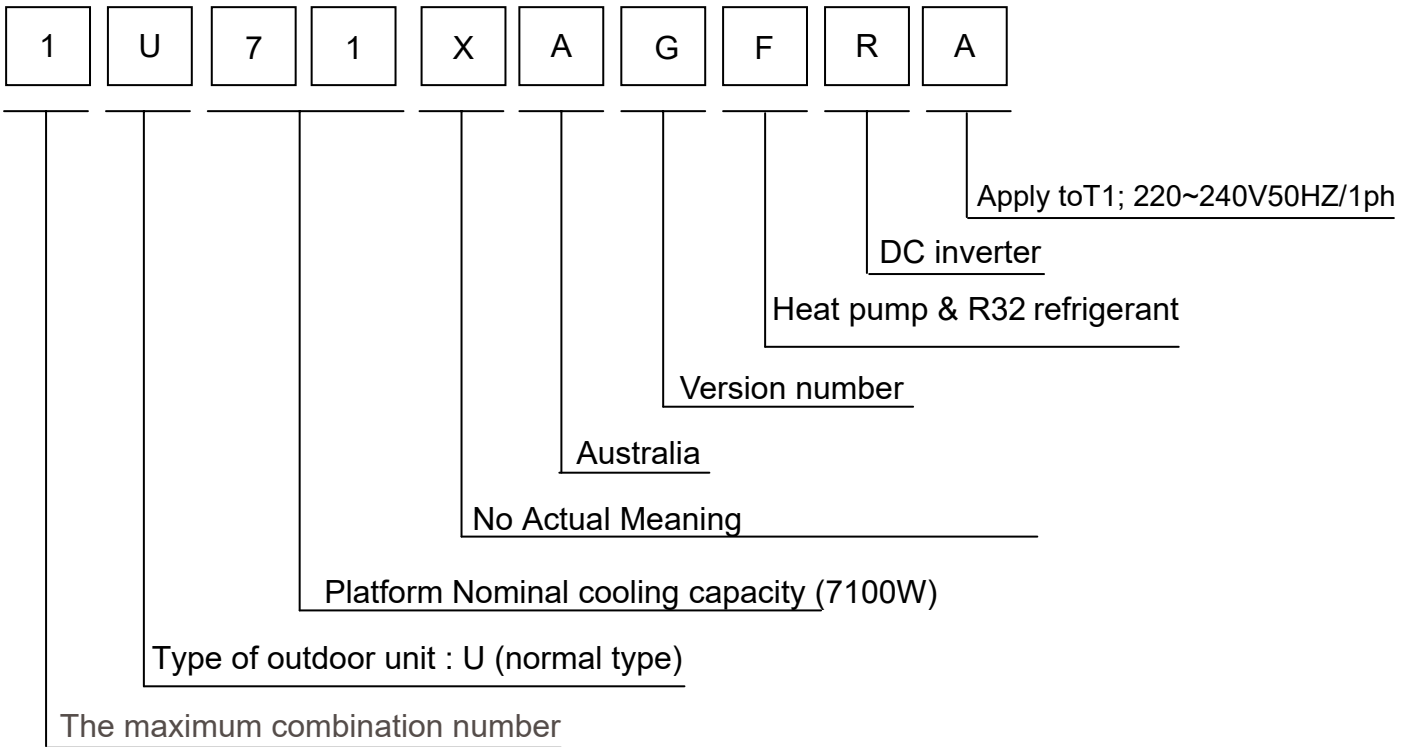

2 Specifications

2.1 Specifications-1U71XAGFRA

NOMINAL DISTRIBUTION SYSTEM VOLTAGE		
Phase	/	1
Frequency	Hz	50
Voltage	V	220~240

NOMINAL CAPACITY and NOMINAL INPUT			
		cooling	heating
Capacity rated	KW	7.1	8.0
	Btu/h	/	/
Power Consumption(Rated)	KW	1.86	2.14
EER/COP	W/W	3.82	3.74
Annual energy consumption	KWh	/	/
Moisture Removal	m ³ /h	3.0*10 ⁻³	

TECHNICAL SPECIFICATIONS-UNIT			
Dimensions	H*W*D	mm	950×370×815
Packaged Dimensions	H*W*D	mm	1090×475×887
Weight	/	kg	52.0
Gross weight	/	kg	56.0
Sound level	Sound pressure	dB	60
	Sound power	dB(A)	67

ELECTRICAL SPECIFICATIONS			
		cooling	heating
Nominal running current	A	8.1	9.5
Maximum running current	A	13	16.0
Starting current	A	1.3	1.3

TECHNICAL SPECIFICATIONS-PARTS			
		cooling	heating
Compressor	Type	Rotary Compressor	
	Model	GTD226RKQC8LU8C	
	Motor output	W	2055
	Oil type	POE	
	Oil charge volume	L	0.9
Fan	Type	Axial fan	
	Motor output	W	90
	Air flow rate(high)	m ³ /h	3000
	Speed(high/low)	rpm	800/300
Heat exchanger	Type	ML fin- φ 7 HI-HX tube	
	Row*stage*fitch	2*30*1.4	

TECHNICAL SPECIFICATIONS-OTHERS				
Refrigerant circuit	Refrigerant type		R32	
	Refrigerant charge	KG	1.65	
	Maximum allowable distance between indoor an outdoor		m	50
	Maximum allowable level difference		m	30
	Refrigerant control		Electronic expansion valve	
Piping connections (external diameter)	liquid	mm	Φ 6.35	
	gas	mm	Φ15.88	
	drain	mm	Φ16	
Heat insulation type		Both liquid and Gas pipes		
Max. piping Length		m	50	
Max. Level Difference		m	30	
Chargless Length		m	10	
Amount of Additional Charge of Refrigerant		g/m	20	
International Protection degree			IPX4	

Note: the data are based on the conditions shown in the table below

cooling	heating	Piping length	Conversation formulae Kcal/h= KW×860 Btu/h= KW×3414 cfm=m ³ /min×35.3
Indoor: 27°CDB/19°CWB Outdoor: 35°CDB/24°CWB	Indoor:20°CDB Outdoor: 7°CDB/6°CWB	5m	

Haier

MODEL **1U71XAGFRA**
Split type room air conditioner outdoor unit

Item	Cooling	Heating
Capacity	7100W	8000W
Power input	1860W	2140W
Current	8.1A	9.5A
Maximum Current	13.0A	16.0A
Maximum Allowable Pressure(Hi/Lo)	4.3MPa/4.3MPa	
Power Supply	220-240V~,50Hz	
Refrigerant	R32 1.65 kg	
Net Weight	52.0kg	
Protection	IPX4	
Item Number(FPA)	51829	



AS/NZS 4755 SELV DC Power
 DRM 1 DRM 2 DRM 3



OUTSIDE SOUND POWER LEVEL 67 dB(A)

Lower sound levels means lower outside noise. The level shown above may be used to estimate whether the outside noise from the proposed installation of this unit will be within acceptable limits. Consult your supplier before installation.

Serial NO.

XXXXXXXXXXXXXXXXXXXX

Manufacture date
 Made in P.R.C. 00105112633



Outdoor Nameplate

3 Sensors list

type	Description	Qty
Ambient sensor	Its used for detecting temperature of outdoor side	1
Defrosting sensor	Its used for controlling outdoor defrosting at heating mode	
Discharging sensor	Its used for compressor in case of over-heat	

4 Pinping diagrams

Cooling mode

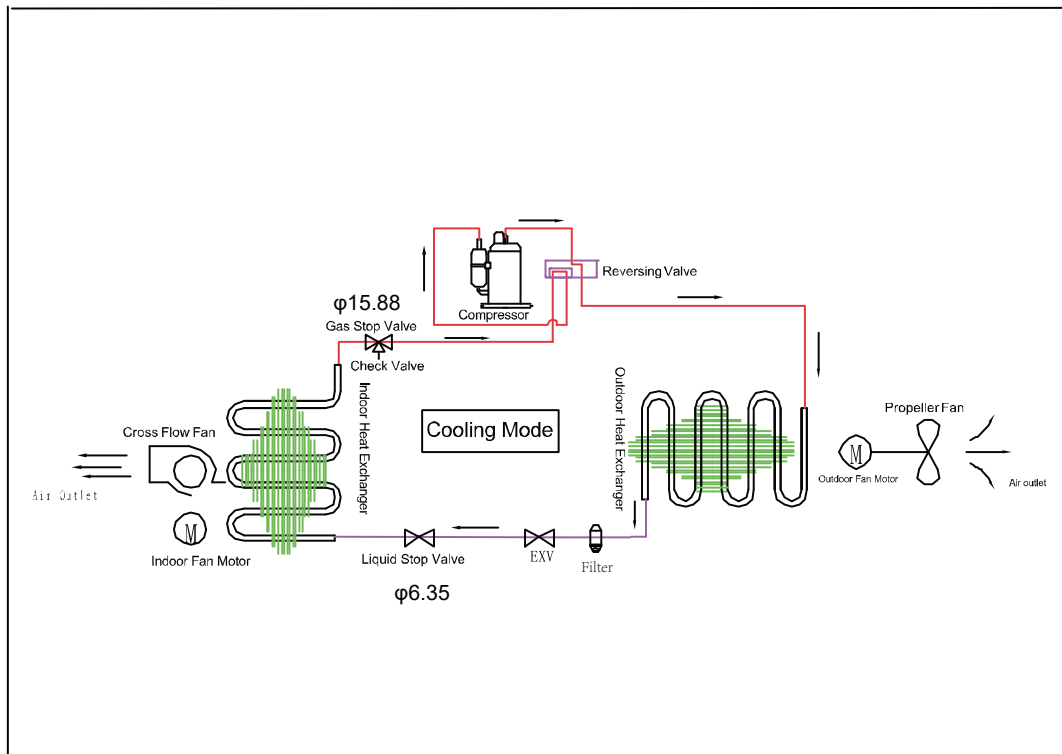

Heating mode

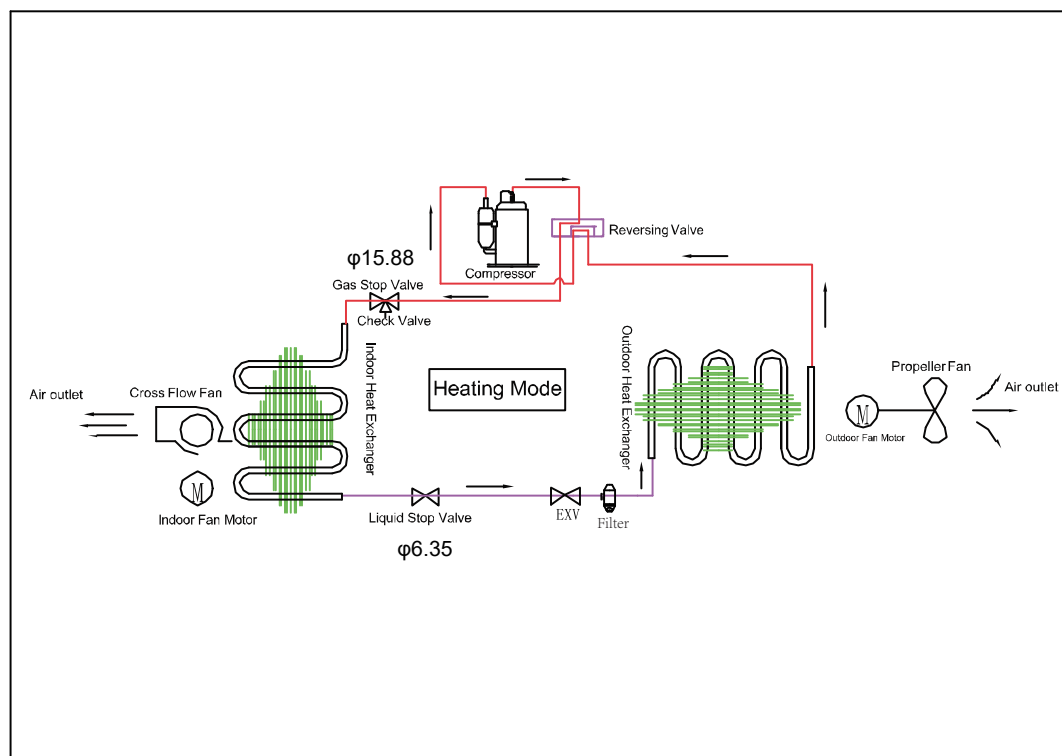

5 Operation range

The name of parts

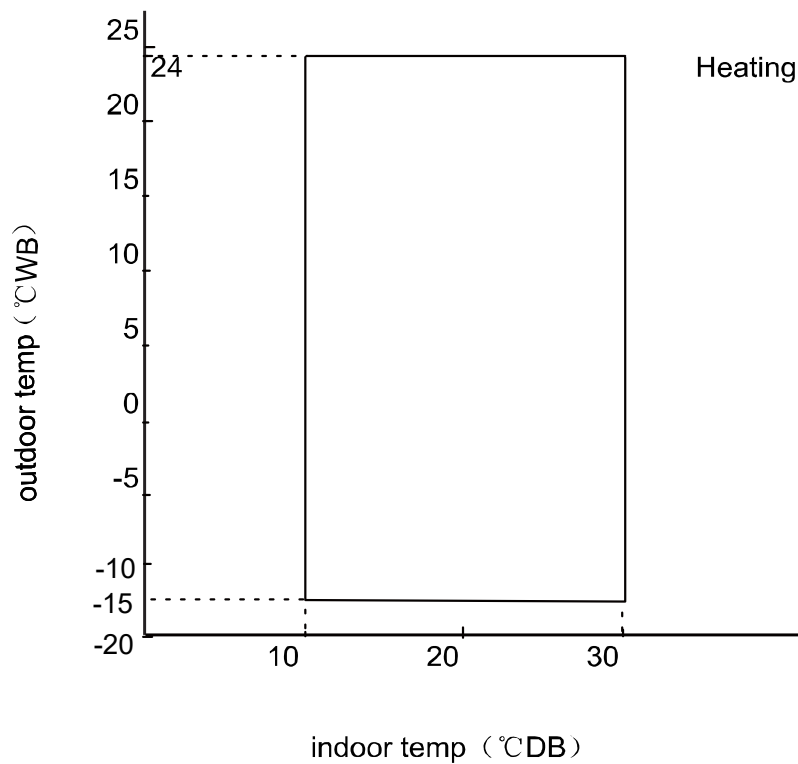
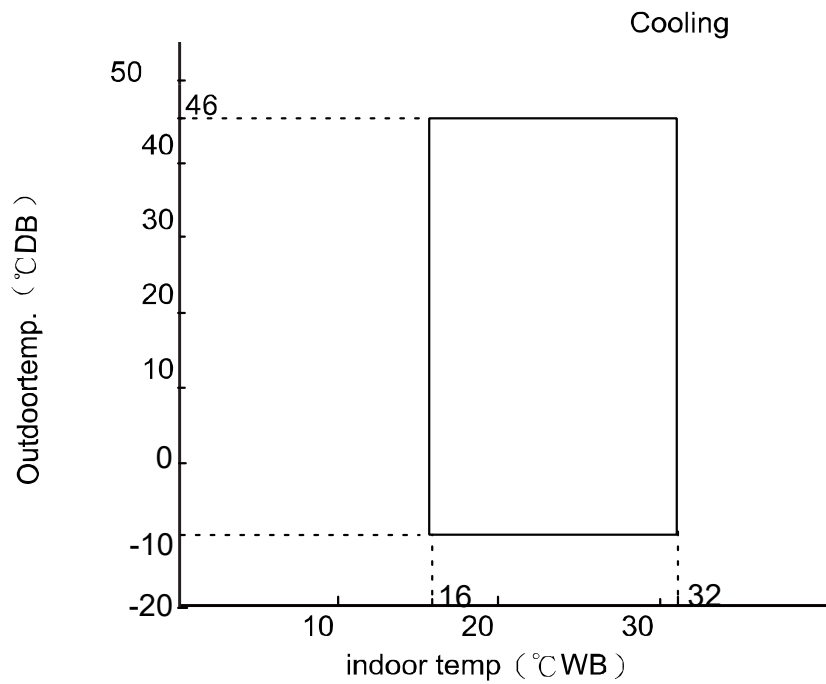

Notes:

The graphs are based on the following condition:

Equivalent piping length	5m
Level difference	0m
Air flow rate	high

6 Printed Circuit Board Connector Wiring Diagram

Connectors

PCB (Outdoor Control PCB)

1	CN1	Connector for power N and L
2	CN2	
3	CN3	Connector for ground
4	CN7	Connector for the U, V, W wire of the compressor
5	CN8	
6	CN9	
7	CN5	Connector for fan motor
8	CN10	Connector for four way valve coil
9	CN20	Connector for Temperature sensor
10	CN4	Connector for communicate between indoor and outdoor unit
11	CN16	Connector for electric expansion valves
12	CN49	Connector for DRED

Connectors

DRED PCB

1	CN1	Connector for DRED line
2	CN2	Connector for PCB CN9

Note: Other Designations

- 1) FUSE 1, (20A, 250VAC); FUSE 2(3.15A, 250VAC)
- 2) LED 1 Keep light representative normal, if keep flash interval representative trouble Alarm
- 3) RV1, RV2, RV3 Varistor

DRED PCB

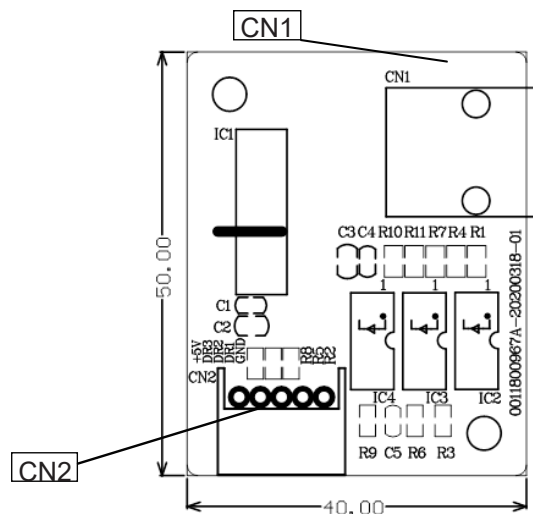

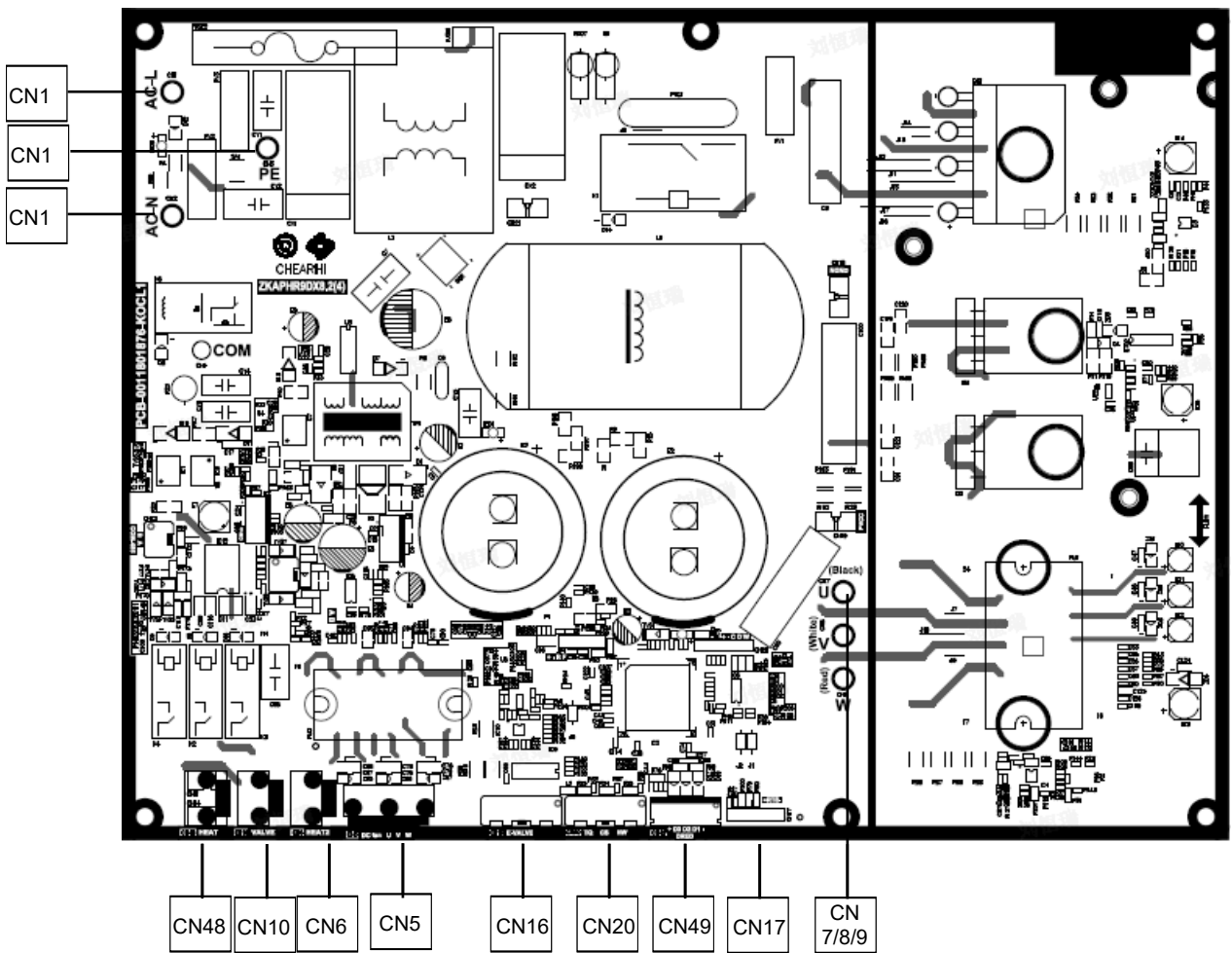
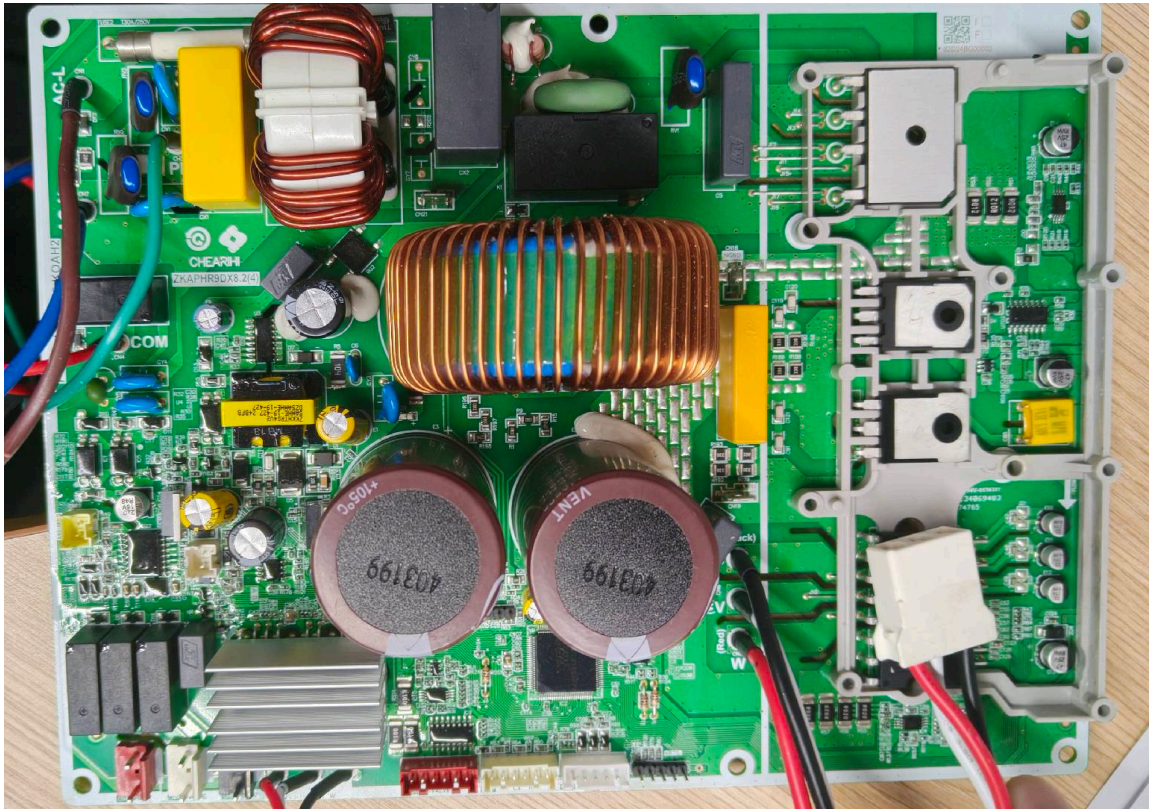

PCB

Wiring diagrams

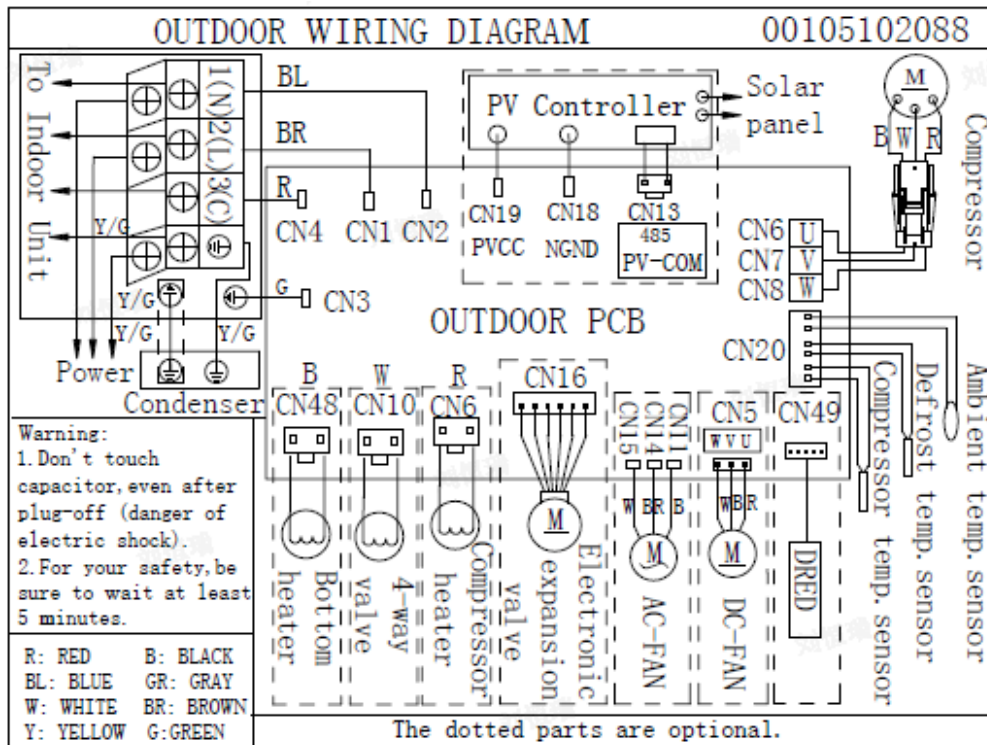

Refrigerant charge label

R32

① = kg

② = kg

① + ② = kg

- ① factory refrigerant charge of the product: see unit name plate
- ② additional refrigerant amount charged in the field: see installation manual
- ③ total refrigerant charge

0011534428

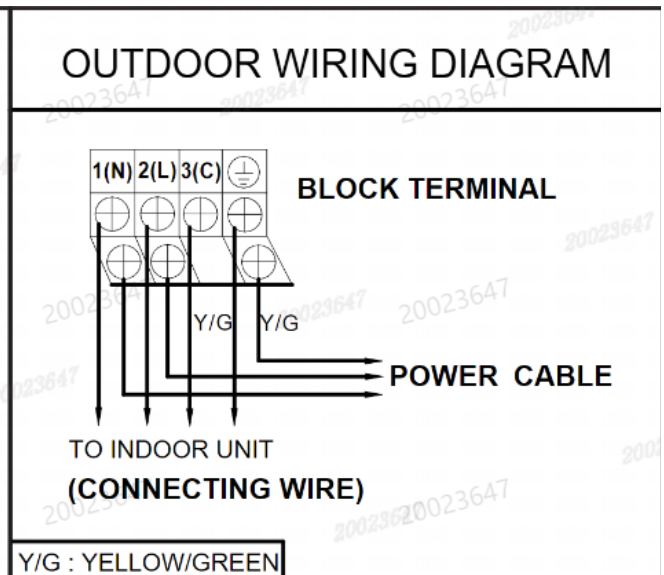

7 Outdoor Functions and Control

7.1 Main functions and control specification

7.1.1 The operation frequency of outdoor unit and its control

7.1.1.1 The operation frequency control of compressor

The operation frequency scope of compressor:

Mode	Minimum operation frequency	Maximum operation frequency
cooling	20Hz	62Hz
heating	20Hz	84Hz

7.1.1.2 The starting of compressor

When the compressor is started for the first time, it must be kept under the conditions of 38Hz,58Hz,88Hz for 30second,one minute, one minute (the overheating protection of the outdoor unit air-blowing temperature, immediately decrease the frequency when the compressor is overflowing and releasing the pressure), then it can be operated towards the target frequency. When the machine runs normally, there's no such process. After starting the compressor for operation, the compressor should run according to the calculated frequency, and every determined frequency for protection should be prior to the calculated frequency.

7.1.1.3 The speeds of increasing or decreasing the frequency of the compressor

The speed of increasing or decreasing the frequency rapidly 1 -----1HZ/second

The speed of increasing or decreasing the frequency slowly 2 -----1HZ/10seconds

7.1.1.4 The calculation of the compressor's frequency

Refrigeration/dehumidification mode:

$$P_n = (N_h_c - S_c) * 10 \geq 50 \text{ outdoor environment control}$$

$$P_n = (N_h_c - S_c) * 10 < 50 \text{ PID control}$$

Heating mode:

$$P_n = (S_c - N_h_c) * 10 \geq 60 \text{ outdoor environment control}$$

$$P_n = (S_c - N_h_c) * 10 < 60 \text{ PID control}$$

(N_h_c =indoor ● environment temperature S_c =setting temperature)

1) The minimum/maximum frequency limitation

A. While refrigerating: F-MAX-r is the maximum operation frequency of the compressor; F-MIN-r is the minimum operation frequency of the compressor.

B. While heating: F-MAX-d is the maximum operation frequency of the compressor; F-MIN-d is the minimum operation frequency of the compressor.

2) The frequency limitation which is affected by the environment temperature.

(W_h_c = environment temperature)

Heating mode:

Serial No.	Temperature scope	Frequency limitation
1	$W_h_c < -12$	Max_hz1 84HZ
2	$W_h_c < -8$	Max_hz2 84HZ
3	$W_h_c < -2$	Max_hz3 84 HZ
4	$W_h_c < 5$	Max_hz4 76 HZ

5	Wh_c<10	Max_hz5 66 HZ
6	Wh_c<17	Max_hz6 56 HZ
7	Wh_c<20	Max_hz7 45 HZ
8	Wh_c>=20	Max_hz8 36HZ

Remarks: The above are the maximum frequency limitations of the complete appliance which are affected by the environment, and they have nothing to do with the ability of the indoor unit.

Refrigeration/dehumidification mode:

Serial No.	Temperature scope	Frequency limitation
1	Wh_c<16	Max_hz1 28 HZ
2	Wh_c<22	Max_hz2 35 HZ
3	Wh_c<29	Max_hz3 40 HZ
4	Wh_c<32	Max_hz4 49HZ
5	Wh_c<40	Max_hz5 61 HZ
6	Wh_c<48	Max_hz6 51 HZ
7	Wh_c>=48	Max_hz7 34 HZ

Remarks: the above are not only the maximum frequency limitations of the complete appliance which are affected by the environment, but also the maximum ability limitation of the system. When the starting ability is not the maximum, its maximum frequency limitation is calculated by the following equations:

The frequency limitation which is affected by the temperature and under the condition of actual ability=the actual running system ability*the maximum frequency which is limited by the temperature and under the condition of maximum ability/the maximum designing ability of the system

Refrigeration/dehumidification mode:

The indoor setting airflow speed	Low	Medium	Quiet
The percentage of the rated frequency K	60%	75%	55%

Heating mode:

The indoor setting airflow speed	Low	Medium	Quiet
The percentage of the rated frequency K	55%	60%	45%

The calculation of the actual output frequency:

$$F = F-ED \cdot (\text{rated frequency}) \times K$$

$$F-ED \cdot (\text{rated frequency}) = \text{The frequency which is limited by the outdoor environment temperature}$$

Notes:

When refrigerating, it is needed to satisfy

$$F-MIN-d(\text{compressor's Min_hz}) < F < F-MAX-d(\text{compressor's Max_hz})$$

When heating, it is needed to satisfy

$$F-MIN-r(\text{compressor's Min_hz}) < F < F-MAX-r(\text{compressor's Max_hz})$$

PID control :

The initial frequency S_n is determined by P_n . We can calculate H_{zoutf} according to the value of K_p , K_i , K_d , Out_gain , P_n . Then, $F_n = S_n + H_{zoutf}$. The value of F_n is calculated in each sample time (60 seconds), and F_n is adjusted. According to previous frequency of S_n and filtered output of H_{zoutf} .

7.1.2 The outdoor fan control (Exchange fan)

When the fan is changed among every airflow speed (including stop blowing), in order to avoid the airflow speed from skipping frequently, it must be kept under each mode for over 30 seconds, and then it can be changed to another mode (when refrigerating, the time is changed to 15 seconds).

7.1.2.1 The outdoor DC fan control

Within three minutes of compressor starting, the compressor is controlled according to the ambient temperature.

Tao (°C)	Tao <22°C	22°C < Tao <29°C	Tao ≥29°C
Refrigeration/dehumidification	720r	730r	740r
Tao (°C)	Tao <10°C	10°C < Tao <17°C	Tao ≥17°C
Heating	750r	760r	770r

After 3 minutes, the compressor is controlled according to the ambient temperature and the frequency of the compressor.

Refrigeration/dehumidification frequency (Hz)		<51 Hz	51-70 Hz	≥70Hz
Tao (°C)	≤22°C	500r	600r	700r
	22-29°C	550r	650r	750r
	29-38°C	600r	700r	800r
	≥38°C	800r		
Heating frequency (Hz)		<51 Hz	51-70 Hz	≥70 Hz
Tao (°C)	≤10°C	600r	700	800
	10-18°C	550r	700r	800r
	≥17°C	550r		

7.1.4 Four way control

For the details of defrosting four-way valve control, see the defrosting process.

Four way working in other ways:

Under the mode of heating, open the four-way valve, when the compressor is not started or changed to non-heating mode, make sure the compressor is stopped for 2 minutes, and then close the four-way valve.

7.1.5 Protection function

7.1.5.1 TTC high temperature-preventing protection

Once the machine is started, it can run TTC (air-blowing temp) overheating protection of air-blowing, but air-blowing sensor malfunction must alarm after 4 minutes during which the compressor is started (during the course of self-detection, there's no such limitation.)

Sensor detection methods: 100 times (one cycle of procedure run is one time, and about 5ms, detection method for each time: continuously sampling for 8 times, then order them and take the mean value of the middle2 values), take the mean value.

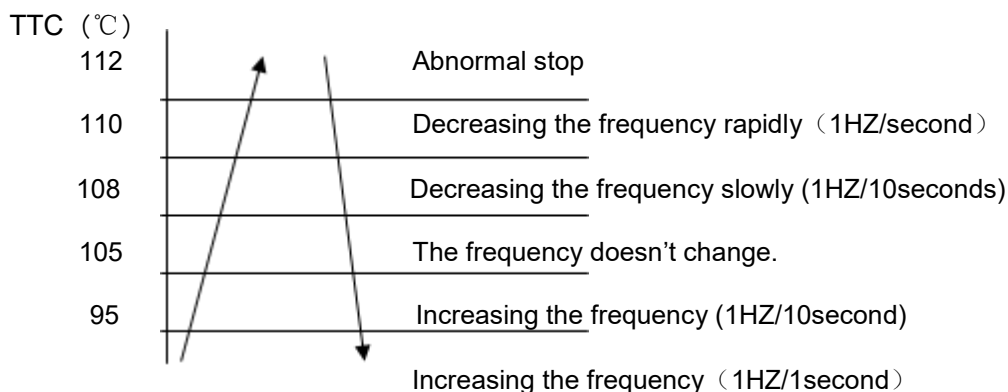

TTC \geq 112°C, lasts for 20 seconds. Overheating protection of air-blowing, alarm malfunction to the indoor, others don't last.

7.1.5.2 TC high temperature-preventing control of the indoor heating unit:

Tpg_indoor is the highest value of the effective indoor unit (start it and it is in accord with the running state). TC=indoor coil temp.

The indoor heat exchanger sensor tests the temperature of the indoor heat exchanger. If the temperature is higher than 63°C, decrease the rotate speed of the compressor and do the high temperature-preventing protection of the indoor heat exchanger; if the temperature of the indoor heat exchanger is lower than 45°C, recover to the normal control.

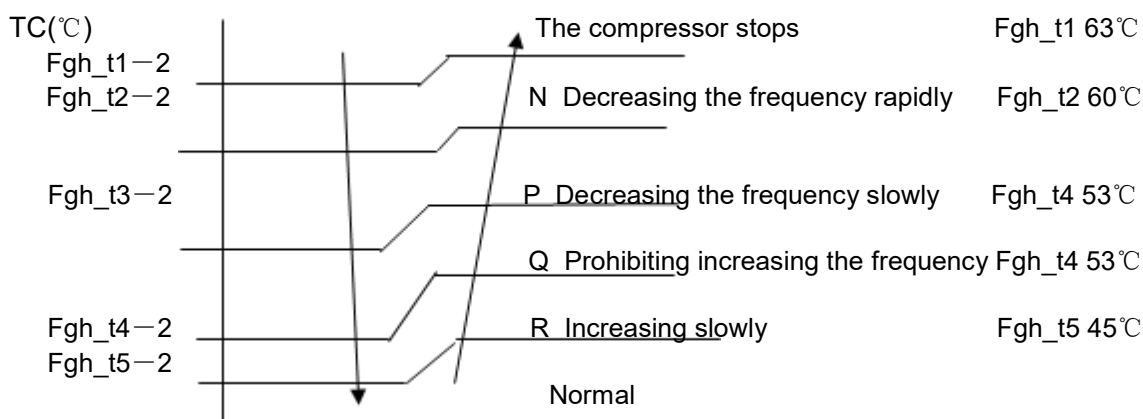

- N: Decreasing at the speed of 1HZ/1 second .
- P: Decreasing at the speed of 1Hz/10 seconds .
- Q: Continue to keep the last-time instruction cycle
- R: Increasing at the speed of 1Hz/10seconds

Remarks: the outdoor unit

7.1.5.3 The control of preventing the over current of the compressor:

- During the starting process of the compressor, if the current of the compressor is greater than 20.5A for 3 seconds, stop the compressor and alarm, after 3 minutes, start it again, if such state appears 3 times in 20 minutes, stop the compressor and alarm, and confirm the malfunction. Then continue to run it only after the power is off.

- During the starting process of the compressor, if the AC current is greater than 19A, the frequency of the compressor decreases at the speed of 1HZ/second.

- During the starting process of the compressor, if the AC current is greater than 18A, the frequency of the compressor decreases at the speed of 0.1HZ/second.

- During the starting process of the compressor, if the AC current is greater than 17A, the frequency of the compressor increases at the prohibited speed.
- During the starting process of the compressor, if the AC current is greater than 12.5A, the frequency of the compressor increases at the speed of no faster than 0.1HZ/second.

7.1.5.4 The protection function of AC current:

During the starting process of the compressor, if the AC current is greater than 20.5A for 3 seconds, stop the compressor and alarm, after 3 minutes, start it again, if such state appears 3 times in 20 minutes, stop the compressor and alarm, and confirm the malfunction. Then continue to run it only after the the power is off.

During the starting process of .the compressor, if the AC current is greater than 19A, the frequency of the compressor decreases at the speed of 1HZ/second.

During the starting process of the compressor, if the AC current is greater than 18A, the frequency of the compressor decreases at the speed of 0.1HZ/second.

During the starting process of the compressor, if the AC current is greater than 17A, the frequency of the compressor increases at the prohibited speed.

During the starting process of the compressor, if the AC current is greater than 12.5A, the frequency of the compressor increases at the speed of no faster than 0.1HZ/second.

Remarks: when the outdoor temperature is high, there's compensation for AC current protection.

(1) When the outdoor environment temperature is higher than 40°C, AC current protection value decreases by 1A.

(2) When the outdoor environment temperature is higher than 50°C, AC current protection value decreases by 2A.

7.1.5.5 Anti-freezing protection of the indoor heat exchanger:

When refrigerating/heating, prevent freezing.

Tpg_indoor is the minimum value of the effective indoor unit (start it and it is in accord with the running state).

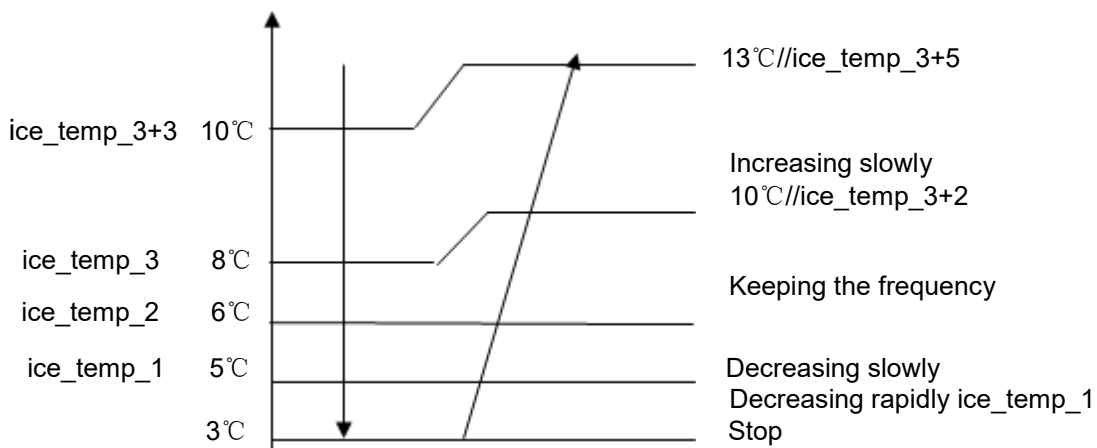

When $Tpg_indoor < ice_temp_1$, the frequency of the compressor decreases at the speed of 1HZ/1second.

When $Tpg_indoor < ice_temp_2$, the frequency of the compressor decreases at the speed of 1HZ/10seconds.

When Tpg_indoor begins to rise again, and $ice_temp_2 \leq Tpg_indoor \leq ice_temp_3$, the frequency of the compressor doesn't change.

When $ice_temp_3 < Tpg_indoor < ice_temp_3+3^\circ C$, the frequency of the compressor increases at the

speed of 1HZ/10seconds.

For example, $T_{pg_indoor} \leq 0^{\circ}\text{C}$, last for 2 minutes, and then the outdoor unit will stop, and report underload malfunction, but don't send malfunction report to the indoor.

The compressor stops for more than 3 minutes, $T_{pg_indoor} > ice_temp_3 + 2^{\circ}\text{C}$, the compressor recovers.

7.1.5.6 The frequency limitation of modification rate:

In the field which is controlled by high frequency, if the modification rate is not high enough, the control-driven chip will enter into weak magnetic control, this will help to relieve the problem of modification rate. If during the course of weak magnetic control, the modification rate is still not high enough, enter into the control of decreasing frequency until the alarm of modification rate is relieved.

7.1.5.7 Temperature protection of the outdoor refrigerating coil

When the defrosting temperature and the sensor's temperature are higher than 68°C , the frequency of the compressor decreases 1hz/10seconds. Keep the frequency until it decreases to the lowest frequency. When the temperatures are lower than 68°C and higher than 62°C , keep the frequency of the compressor. When the temperatures are lower than 62°C , relieve the defrosting temperature protection.

7.2 Value of Thermistor

7.2.1 Outdoor Unit

Ambient Sensor, Defrosting Sensor, Pipe sensor

$R_{25^{\circ}\text{C}} = 10\text{K}\Omega \pm 3\%$ $B_{25^{\circ}\text{C}/50^{\circ}\text{C}} = 3700\text{K} \pm 3\%$

Temp.($^{\circ}\text{C}$)	Max.(K Ω)	Normal(K Ω)	Min.(K Ω)	Tolerance($^{\circ}\text{C}$)	
-30	165.2170	147.9497	132.3678	-1.94	1.75
-29	155.5754	139.5600	125.0806	-1.93	1.74
-28	146.5609	131.7022	118.2434	-1.91	1.73
-27	138.1285	124.3392	111.8256	-1.89	1.71
-26	130.2371	117.4366	105.7989	-1.87	1.70

-25	122.8484	110.9627	100.1367	-1.85	1.69
-24	115.9272	104.8882	94.8149	-1.83	1.67
-23	109.4410	99.1858	89.8106	-1.81	1.66
-22	103.3598	93.8305	85.1031	-1.80	1.64
-21	97.6556	88.7989	80.6728	-1.78	1.63
-20	92.3028	84.0695	76.5017	-1.76	1.62
-19	87.2775	79.6222	72.5729	-1.74	1.60
-18	82.5577	75.4384	68.8710	-1.72	1.59
-17	78.1230	71.5010	65.3815	-1.70	1.57
-16	73.9543	67.7939	62.0907	-1.68	1.55
-15	70.0342	64.3023	58.9863	-1.66	1.54
-14	66.3463	61.0123	56.0565	-1.64	1.52
-13	62.8755	57.9110	53.2905	-1.62	1.51
-12	59.6076	54.9866	50.6781	-1.60	1.49
-11	56.5296	52.2278	48.2099	-1.58	1.47
-10	53.6294	49.6244	45.8771	-1.56	1.46
-9	50.8956	47.1666	43.6714	-1.54	1.44
-8	48.3178	44.8454	41.5851	-1.51	1.42
-7	45.8860	42.6525	39.6112	-1.49	1.40
-6	43.5912	40.5800	37.7429	-1.47	1.39
-5	41.4249	38.6207	35.9739	-1.45	1.37
-4	39.3792	36.7676	34.2983	-1.43	1.35
-3	37.4465	35.0144	32.7108	-1.41	1.33
-2	35.6202	33.3552	31.2062	-1.38	1.31
-1	33.8936	31.7844	29.7796	-1.36	1.29
0	32.2608	30.2968	28.4267	-1.34	1.28
1	30.7162	28.8875	27.1431	-1.32	1.26
2	29.2545	27.5519	25.9250	-1.29	1.24
3	27.8708	26.2858	24.7686	-1.27	1.22
4	26.5605	25.0851	23.6704	-1.25	1.20
5	25.3193	23.9462	22.6273	-1.23	1.18
6	24.1432	22.8656	21.6361	-1.20	1.16
7	23.0284	21.8398	20.6939	-1.18	1.14
8	21.9714	20.8659	19.7982	-1.15	1.12
9	20.9688	19.9409	18.9463	-1.13	1.09
10	20.0176	19.0621	18.1358	-1.11	1.07
11	19.1149	18.2270	17.3646	-1.08	1.05
12	18.2580	17.4331	16.6305	-1.06	1.03
13	17.4442	16.6782	15.9315	-1.03	1.01
14	16.6711	15.9601	15.2657	-1.01	0.99
15	15.9366	15.2770	14.6315	-0.98	0.96
16	15.2385	14.6268	14.0271	-0.96	0.94
17	14.5748	14.0079	13.4510	-0.93	0.92
18	13.9436	13.4185	12.9017	-0.91	0.90

19	13.3431	12.8572	12.3778	-0.88	0.87
20	12.7718	12.3223	11.8780	-0.86	0.85
21	12.2280	11.8126	11.4011	-0.83	0.83
22	11.7102	11.3267	10.9459	-0.81	0.80
23	11.2172	10.8634	10.5114	-0.78	0.78
24	10.7475	10.4216	10.0964	-0.75	0.75
25	10.3000	10.0000	9.7000	-0.75	0.75
26	9.8975	9.5974	9.2980	-0.76	0.76
27	9.5129	9.2132	8.9148	-0.80	0.80
28	9.1454	8.8465	8.5496	-0.84	0.83
29	8.7942	8.4964	8.2013	-0.87	0.86
30	8.4583	8.1621	7.8691	-0.91	0.90
31	8.1371	7.8428	7.5522	-0.95	0.93
32	7.8299	7.5377	7.2498	-0.98	0.97
33	7.5359	7.2461	6.9611	-1.02	1.00
34	7.2546	6.9673	6.6854	-1.06	1.04
35	6.9852	6.7008	6.4222	-1.10	1.07
36	6.7273	6.4459	6.1707	-1.13	1.11
37	6.4803	6.2021	5.9304	-1.17	1.14
38	6.2437	5.9687	5.7007	-1.21	1.18
39	6.0170	5.7454	5.4812	-1.25	1.22
40	5.7997	5.5316	5.2712	-1.29	1.25
41	5.5914	5.3269	5.0704	-1.33	1.29
42	5.3916	5.1308	4.8783	-1.37	1.33
43	5.2001	4.9430	4.6944	-1.41	1.36
44	5.0163	4.7630	4.5185	-1.45	1.40
45	4.8400	4.5905	4.3500	-1.49	1.44
46	4.6708	4.4252	4.1887	-1.53	1.47
47	4.5083	4.2666	4.0342	-1.57	1.51
48	4.3524	4.1145	3.8862	-1.61	1.55
49	4.2026	3.9686	3.7443	-1.65	1.59
50	4.0588	3.8287	3.6084	-1.70	1.62
51	3.9206	3.6943	3.4780	-1.74	1.66
52	3.7878	3.5654	3.3531	-1.78	1.70
53	3.6601	3.4416	3.2332	-1.82	1.74
54	3.5374	3.3227	3.1183	-1.87	1.78
55	3.4195	3.2085	3.0079	-1.91	1.82
56	3.3060	3.0989	2.9021	-1.95	1.85
57	3.1969	2.9935	2.8005	-2.00	1.89
58	3.0919	2.8922	2.7029	-2.04	1.93
59	2.9909	2.7948	2.6092	-2.08	1.97
60	2.8936	2.7012	2.5193	-2.13	2.01
61	2.8000	2.6112	2.4328	-2.17	2.05
62	2.7099	2.5246	2.3498	-2.22	2.09
63	2.6232	2.4413	2.2700	-2.26	2.13

64	2.5396	2.3611	2.1932	-2.31	2.17
65	2.4591	2.2840	2.1195	-2.36	2.21
66	2.3815	2.2098	2.0486	-2.40	2.25
67	2.3068	2.1383	1.9803	-2.45	2.29
68	2.2347	2.0695	1.9147	-2.49	2.34
69	2.1652	2.0032	1.8516	-2.54	2.38
70	2.0983	1.9393	1.7908	-2.59	2.42
71	2.0337	1.8778	1.7324	-2.63	2.46
72	1.9714	1.8186	1.6761	-2.68	2.50
73	1.9113	1.7614	1.6219	-2.73	2.54
74	1.8533	1.7064	1.5697	-2.78	2.58
75	1.7974	1.6533	1.5194	-2.83	2.63
76	1.7434	1.6021	1.4710	-2.88	2.67
77	1.6913	1.5528	1.4243	-2.92	2.71
78	1.6409	1.5051	1.3794	-2.97	2.75
79	1.5923	1.4592	1.3360	-3.02	2.80
80	1.5454	1.4149	1.2942	-3.07	2.84
81	1.5000	1.3721	1.2540	-3.12	2.88
82	1.4562	1.3308	1.2151	-3.17	2.93
83	1.4139	1.2910	1.1776	-3.22	2.97
84	1.3730	1.2525	1.1415	-3.27	3.01
85	1.3335	1.2153	1.1066	-3.32	3.06
86	1.2953	1.1794	1.0730	-3.38	3.10
87	1.2583	1.1448	1.0405	-3.43	3.15
88	1.2226	1.1113	1.0092	-3.48	3.19
89	1.1880	1.0789	0.9789	-3.53	3.24
90	1.1546	1.0476	0.9497	-3.58	3.28
91	1.1223	1.0174	0.9215	-3.64	3.33
92	1.0910	0.9882	0.8942	-3.69	3.37
93	1.0607	0.9599	0.8679	-3.74	3.42
94	1.0314	0.9326	0.8424	-3.80	3.46
95	1.0030	0.9061	0.8179	-3.85	3.51
96	0.9756	0.8806	0.7941	-3.90	3.55
97	0.9490	0.8558	0.7711	-3.96	3.60
98	0.9232	0.8319	0.7489	-4.01	3.64
99	0.8983	0.8088	0.7275	-4.07	3.69
100	0.8741	0.7863	0.7067	-4.12	3.74
101	0.8507	0.7646	0.6867	-4.18	3.78
102	0.8281	0.7436	0.6672	-4.23	3.83
103	0.8061	0.7233	0.6484	-4.29	3.88
104	0.7848	0.7036	0.6303	-4.34	3.92
105	0.7641	0.6845	0.6127	-4.40	3.97
106	0.7441	0.6661	0.5957	-4.46	4.02
107	0.7247	0.6482	0.5792	-4.51	4.07
108	0.7059	0.6308	0.5632	-4.57	4.12

109	0.6877	0.6140	0.5478	-4.63	4.16
110	0.6700	0.5977	0.5328	-4.69	4.21
111	0.6528	0.5820	0.5183	-4.74	4.26
112	0.6361	0.5667	0.5043	-4.80	4.31
113	0.6200	0.5518	0.4907	-4.86	4.36
114	0.6043	0.5374	0.4775	-4.92	4.41
115	0.5891	0.5235	0.4648	-4.98	4.45
116	0.5743	0.5100	0.4524	-5.04	4.50
117	0.5600	0.4968	0.4404	-5.10	4.55
118	0.5460	0.4841	0.4288	-5.16	4.60
119	0.5325	0.4717	0.4175	-5.22	4.65
120	0.5194	0.4597	0.4066	-5.28	4.70

Discharging Sensor

R80°C=50KΩ ± 3%

B25/80°C=4450K ± 3%

Temp.((°C))	Max.(KΩ)	Normal(KΩ)	Min.(KΩ)	Tolerance(°C)	
-30	14646.0505	12061.7438	9924.4999	-2.96	2.45
-29	13654.1707	11267.8730	9290.2526	-2.95	2.44
-28	12735.8378	10531.3695	8700.6388	-2.93	2.44
-27	11885.1336	9847.7240	8152.2338	-2.92	2.43
-26	11096.6531	9212.8101	7641.8972	-2.91	2.42
-25	10365.4565	8622.8491	7166.7474	-2.90	2.42
-24	9687.0270	8074.3787	6724.1389	-2.88	2.41
-23	9057.2314	7564.2244	6311.6413	-2.87	2.41
-22	8472.2852	7089.4741	5927.0206	-2.86	2.40
-21	7928.7217	6647.4547	5568.2222	-2.84	2.39
-20	7423.3626	6235.7109	5233.3554	-2.83	2.39
-19	6953.2930	5851.9864	4920.6791	-2.82	2.38
-18	6515.8375	5494.2064	4628.5894	-2.80	2.37
-17	6108.5393	5160.4621	4355.6078	-2.79	2.37
-16	5729.1413	4848.9963	4100.3708	-2.77	2.36
-15	5375.5683	4558.1906	3861.6201	-2.76	2.35
-14	5045.9114	4286.5535	3638.1938	-2.75	2.34
-13	4738.4141	4032.7098	3429.0191	-2.73	2.34
-12	4451.4586	3795.3910	3233.1039	-2.72	2.33
-11	4183.5548	3573.4260	3049.5312	-2.70	2.32
-10	3933.3289	3365.7336	2877.4527	-2.69	2.31
-9	3699.5139	3171.3148	2716.0828	-2.67	2.30
-8	3480.9407	2989.2460	2564.6945	-2.66	2.29
-7	3276.5302	2818.6731	2422.6139	-2.64	2.28
-6	3085.2854	2658.8058	2289.2164	-2.63	2.28
-5	2906.2851	2508.9126	2163.9230	-2.61	2.27
-4	2738.6777	2368.3158	2046.1961	-2.60	2.26
-3	2581.6752	2236.3876	1935.5371	-2.58	2.25

-2	2434.5487	2112.5459	1831.4826	-2.56	2.24
-1	2296.6230	1996.2509	1733.6024	-2.55	2.23
0	2167.2730	1887.0018	1641.4966	-2.53	2.22
1	2045.9191	1784.3336	1554.7931	-2.52	2.21
2	1932.0242	1687.8144	1473.1460	-2.50	2.20
3	1825.0899	1597.0431	1396.2333	-2.48	2.19
4	1724.6540	1511.6468	1323.7551	-2.47	2.17
5	1630.2870	1431.2787	1255.4324	-2.45	2.16
6	1541.5904	1355.6163	1191.0048	-2.43	2.15
7	1458.1938	1284.3593	1130.2298	-2.41	2.14
8	1379.7528	1217.2282	1072.8813	-2.40	2.13
9	1305.9472	1153.9626	1018.7481	-2.38	2.12
10	1236.4792	1094.3200	967.6334	-2.36	2.11
11	1171.0715	1038.0743	919.3533	-2.35	2.09
12	1109.4661	985.0146	873.7359	-2.33	2.08
13	1051.4226	934.9440	830.6210	-2.31	2.07
14	996.7169	887.6792	789.8583	-2.29	2.06
15	945.1404	843.0486	751.3077	-2.27	2.04
16	896.4981	800.8922	714.8380	-2.26	2.03
17	850.6086	761.0603	680.3265	-2.24	2.02
18	807.3024	723.4134	647.6580	-2.22	2.00
19	766.4212	687.8205	616.7252	-2.20	1.99
20	727.8172	654.1596	587.4271	-2.18	1.98
21	691.3524	622.3161	559.6694	-2.16	1.96
22	656.8979	592.1831	533.3634	-2.14	1.95
23	624.3328	563.6604	508.4261	-2.12	1.93
24	593.5446	536.6540	484.7796	-2.10	1.92
25	564.4275	511.0760	462.3510	-2.09	1.90
26	536.9865	486.9352	441.1516	-2.07	1.89
27	511.0105	464.0500	421.0258	-2.05	1.87
28	486.4151	442.3499	401.9146	-2.03	1.86
29	463.1208	421.7683	383.7626	-2.01	1.84
30	441.0535	402.2430	366.5175	-1.99	1.83
31	420.1431	383.7151	350.1301	-1.97	1.81
32	400.3242	366.1295	334.5542	-1.95	1.80
33	381.5350	349.4341	319.7460	-1.93	1.78
34	363.7176	333.5801	305.6645	-1.90	1.76
35	346.8176	318.5216	292.2709	-1.88	1.75
36	330.7839	304.2151	279.5286	-1.86	1.73
37	315.5682	290.6199	267.4031	-1.84	1.71
38	301.1254	277.6976	255.8620	-1.82	1.70
39	287.4128	265.4119	244.8745	-1.80	1.68
40	274.3905	253.7288	234.4118	-1.78	1.66
41	262.0206	242.6161	224.4465	-1.76	1.64
42	250.2676	232.0436	214.9529	-1.74	1.63

43	239.0983	221.9825	205.9065	-1.71	1.61
44	228.4809	212.4060	197.2844	-1.69	1.59
45	218.3860	203.2887	189.0648	-1.67	1.57
46	208.7855	194.6066	181.2273	-1.65	1.55
47	199.6531	186.3369	173.7524	-1.63	1.54
48	190.9639	178.4584	166.6217	-1.60	1.52
49	182.6945	170.9508	159.8181	-1.58	1.50
50	174.8228	163.7951	153.3249	-1.56	1.48
51	167.3280	156.9733	147.1268	-1.53	1.46
52	160.1904	150.4683	141.2090	-1.51	1.44
53	153.3914	144.2641	135.5577	-1.49	1.42
54	146.9136	138.3454	130.1598	-1.47	1.40
55	140.7403	132.6980	125.0027	-1.44	1.38
56	134.8559	127.3081	120.0746	-1.42	1.36
57	129.2457	122.1630	115.3645	-1.40	1.34
58	123.8956	117.2504	110.8618	-1.37	1.32
59	118.7926	112.5589	106.5564	-1.35	1.30
60	113.9241	108.0776	102.4388	-1.32	1.28
61	109.2784	103.7961	98.5000	-1.30	1.26
62	104.8443	99.7046	94.7315	-1.28	1.23
63	100.6112	95.7939	91.1253	-1.25	1.21
64	96.5692	92.0553	87.6735	-1.23	1.19
65	92.7088	88.4805	84.3690	-1.20	1.17
66	89.0211	85.0614	81.2048	-1.18	1.15
67	85.4976	81.7908	78.1744	-1.15	1.12
68	82.1303	78.6615	75.2715	-1.13	1.10
69	78.9116	75.6668	72.4902	-1.10	1.08
70	75.8343	72.8004	69.8249	-1.08	1.06
71	72.8916	70.0561	67.2703	-1.05	1.03
72	70.0770	67.4283	64.8213	-1.03	1.01
73	67.3844	64.9115	62.4731	-1.00	0.99
74	64.8080	62.5006	60.2211	-0.98	0.96
75	62.3423	60.1906	58.0609	-0.95	0.94
76	59.9821	57.9770	55.9885	-0.92	0.92
77	57.7223	55.8552	53.9998	-0.90	0.89
78	55.5583	53.8210	52.0912	-0.87	0.87
79	53.4856	51.8706	50.2591	-0.85	0.84
80	51.5000	50.0000	48.5000	-0.85	0.84
81	49.7063	48.2057	46.7083	-0.85	0.85
82	47.9835	46.4842	44.9911	-0.89	0.89
83	46.3286	44.8323	43.3452	-0.93	0.92
84	44.7385	43.2468	41.7672	-0.96	0.95
85	43.2105	41.7248	40.2540	-1.00	0.99
86	41.7386	40.2604	38.7996	-1.03	1.02
87	40.3241	38.8545	37.4048	-1.07	1.06

88	38.9643	37.5045	36.0668	-1.11	1.09
89	37.6569	36.2078	34.7831	-1.14	1.13
90	36.3996	34.9622	33.5513	-1.18	1.16
91	35.1903	33.7653	32.3689	-1.22	1.19
92	34.0269	32.6151	31.2338	-1.26	1.23
93	32.9075	31.5096	30.1438	-1.30	1.27
94	31.8302	30.4467	29.0970	-1.33	1.30
95	30.7933	29.4246	28.0915	-1.37	1.34
96	29.7950	28.4417	27.1254	-1.41	1.37
97	28.8337	27.4961	26.1970	-1.45	1.41
98	27.9078	26.5864	25.3048	-1.49	1.44
99	27.0160	25.7110	24.4470	-1.53	1.48
100	26.1569	24.8685	23.6222	-1.57	1.52
101	25.3290	24.0574	22.8291	-1.61	1.55
102	24.5311	23.2765	22.0662	-1.65	1.59
103	23.7620	22.5245	21.3323	-1.69	1.63
104	23.0205	21.8002	20.6261	-1.73	1.66
105	22.3055	21.1025	19.9465	-1.77	1.70
106	21.6159	20.4303	19.2924	-1.81	1.74
107	20.9508	19.7825	18.6626	-1.85	1.77
108	20.3091	19.1582	18.0563	-1.89	1.81
109	19.6899	18.5564	17.4723	-1.93	1.85
110	19.0924	17.9761	16.9098	-1.98	1.89
111	18.5157	17.4166	16.3680	-2.02	1.93
112	17.9590	16.8769	15.8458	-2.06	1.96
113	17.4214	16.3564	15.3427	-2.10	2.00
114	16.9023	15.8542	14.8577	-2.15	2.04
115	16.4010	15.3696	14.3902	-2.19	2.08
116	15.9167	14.9020	13.9394	-2.23	2.12
117	15.4489	14.4506	13.5047	-2.27	2.16
118	14.9968	14.0149	13.0855	-2.32	2.19
119	14.5599	13.5942	12.6811	-2.36	2.23
120	14.1376	13.1879	12.2909	-2.41	2.27
121	13.7294	12.7955	11.9144	-2.45	2.31
122	13.3347	12.4165	11.5510	-2.50	2.35
123	12.9531	12.0503	11.2003	-2.54	2.39
124	12.5840	11.6965	10.8617	-2.58	2.43
125	12.2270	11.3545	10.5348	-2.63	2.47
126	11.8817	11.0240	10.2191	-2.68	2.51
127	11.5475	10.7046	9.9142	-2.72	2.55
128	11.2242	10.3957	9.6197	-2.77	2.59
129	10.9112	10.0970	9.3352	-2.81	2.63
130	10.6084	9.8082	9.0602	-2.86	2.67
131	10.3151	9.5288	8.7945	-2.91	2.71
132	10.0312	9.2586	8.5378	-2.95	2.75

133	9.7563	8.9971	8.2895	-3.00	2.80
134	9.4901	8.7441	8.0495	-3.05	2.84
135	9.2322	8.4993	7.8175	-3.09	2.88
136	8.9824	8.2623	7.5931	-3.14	2.92
137	8.7404	8.0329	7.3760	-3.19	2.96
138	8.5059	7.8108	7.1660	-3.24	3.00
139	8.2787	7.5958	6.9629	-3.29	3.04
140	8.0584	7.3875	6.7664	-3.33	3.09

8 Dimensional drawings

unit:mm

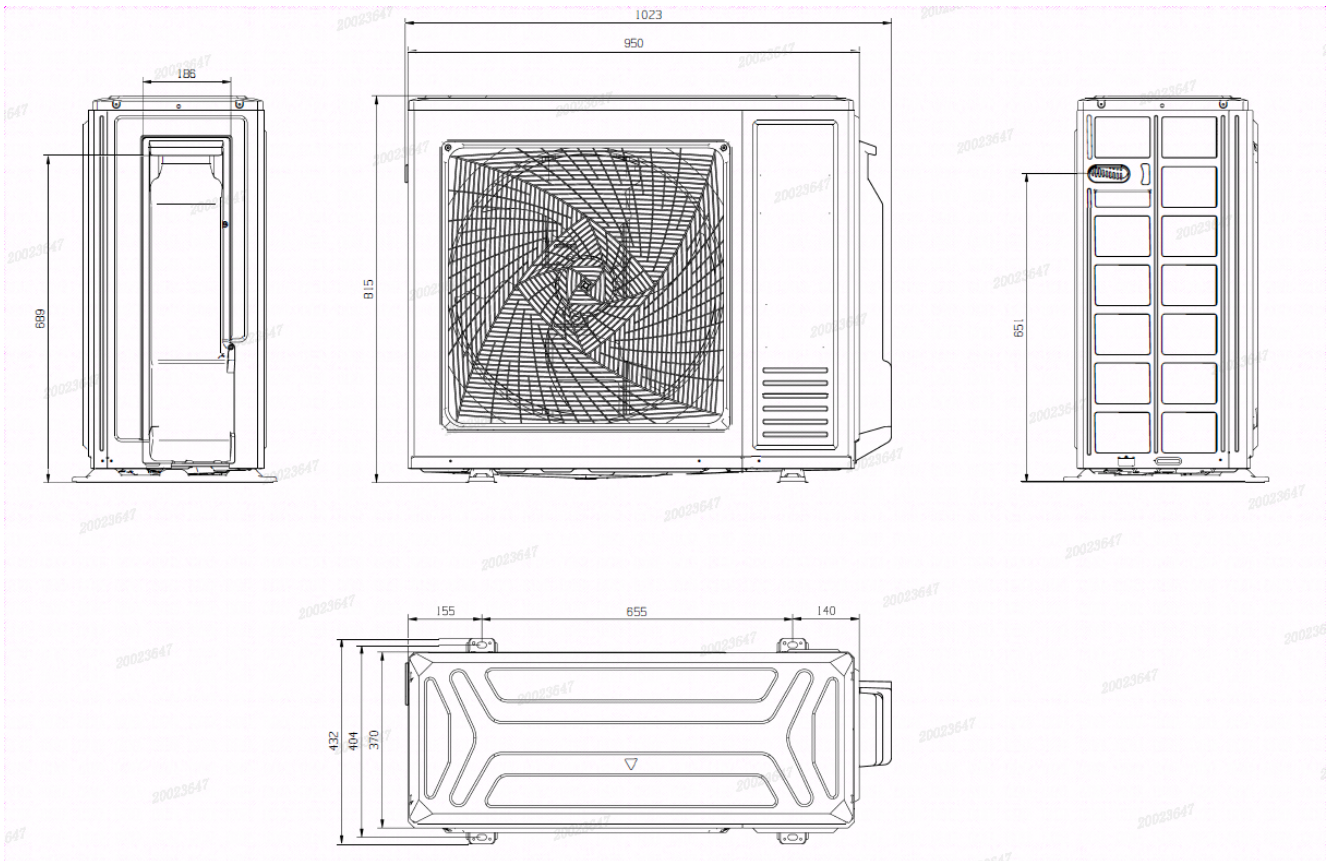

9 Center of gravity

unit:mm

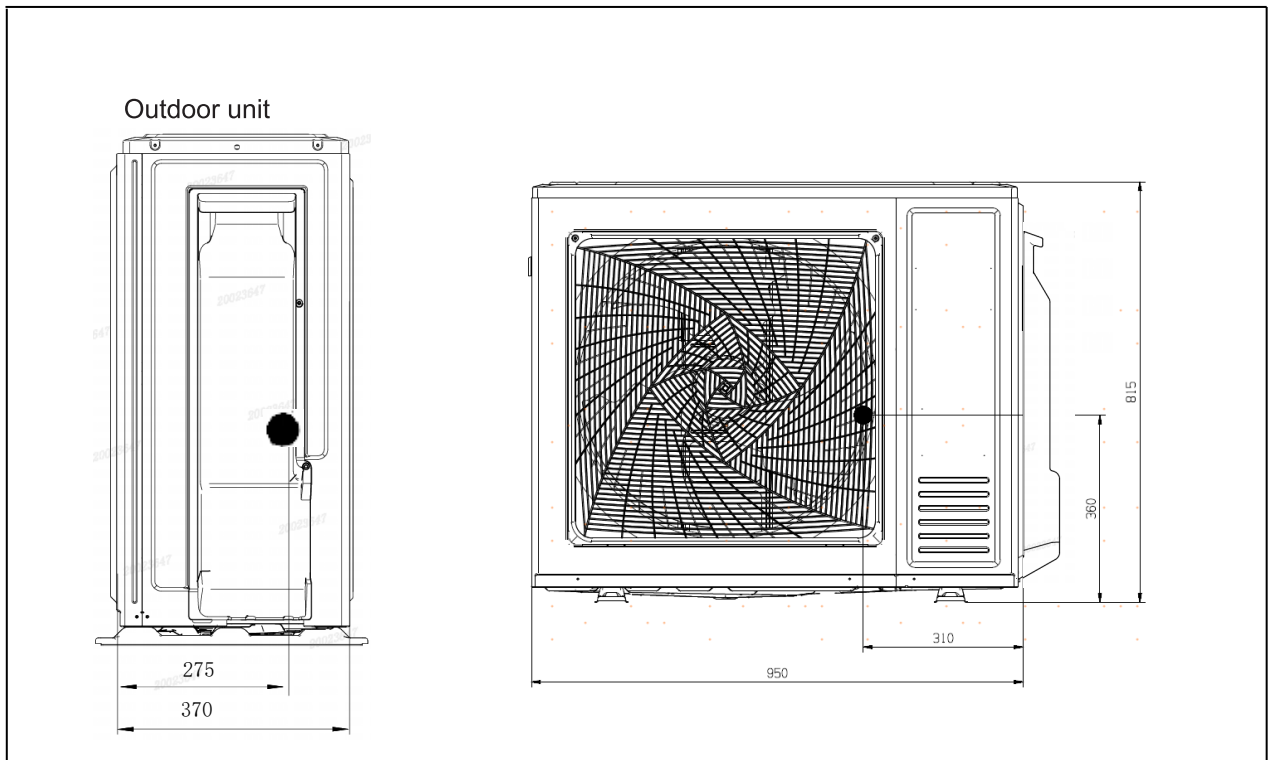

10 Service Diagnosis

10.1 Caution for Diagnosis

The operation lamp flashes when any of the following errors is detected.

1. When a protection device of the indoor or outdoor unit is activated or when the thermistor malfunctions, disabling equipment operation.
2. When a signal transmission error occurs between the indoor and outdoor units. In either case, conduct the diagnostic procedure described in the following pages.

10.2 Problem Symptoms and Measures

Symptom	Check Item	Details of Measure
None of the units operates	Check the power supply.	Check to make sure that the rated voltage is supplied.
	Check the indoor PCB	Check to make sure that the indoor PCB is broken
Operation sometimes stops.	Check the power supply.	A power failure of 2 to 10 cycles can stop air conditioner operation.
Equipment operates but does not cool, or does not heat (only for heat pump)	Check for faulty operation of the electronic expansion valve.	Set the units to cooling operation, and compare the temperatures of the liquid side connection pipes of the connection section among rooms to check the opening and closing operation of the electronic expansion valves of the individual units.
	Diagnosis by service port pressure and operating current.	Check for insufficient gas.
Large operating noise and vibrations	Check the installation condition.	Check to make sure that the required spaces for installation (specified in the Technical Guide, etc.) are provided.

10.3 Parameter of primary electronic appliance

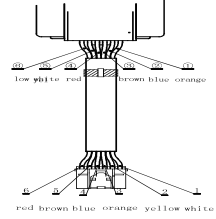
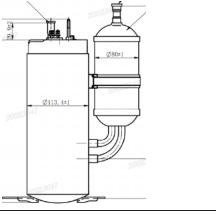
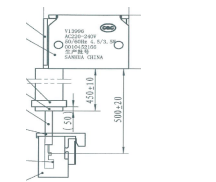
NO	Name	Parameter	Picture
1	ELECTRIC EXPANSION VALVE (0010720125B)	Rated voltage: 12V Valve orifice : $\Phi 1.65\text{mm}$ Coil resistance: $46 \pm 3.7\Omega$	
2	COMPRESSOR (0010747458)	Model: GTD226RKQC8LU8C Rated voltage: 220V/380V Winding Resistance (20°C) : 0.717Ω	
3	4-way valve (0010708049)	Rated voltage: AC 220-240V Rated frequency: 50/60Hz Power: 4.5/3.5W Insulation Resistance: Above 100 MΩ	

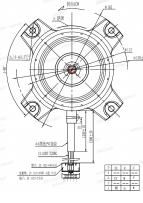
4 DC motor (0010401832U)	Rated input voltage: VDC=310 V/DC Rated load: 90W Rated speed: 900 r/min Resistance : Above 100M Ω	
--------------------------------	---	---

10.4 Error Codes and Description indoor display

Split board: LED1 light of outdoor PCB flash; All-in-one board: LED2 light of outdoor PCB flash

ERROR CODE		OUTDOOR (LED FLASH TIMES)	FAULT DESCRIPTION	SPARE PART
Indoor and Outdoor	E7	15	Communication fault between indoor and outdoor units	Indoor PCB
				Outdoor PCB
				Power module
				Communication wiring
Indoor Malfunction	E1	/	Indoor temperature sensor failure	Room temperature sensor
	E2	/	pipe temperature sensor failure	Indoor PCB
	E4	/	Indoor EEPROM failure	Indoor PCB
	E5	22	Indoor anti-frosting protection	Indoor PCB
				Indoor motor
	E9	21	Indoor unit overload in heating mode	Indoor PCB
				Indoor motor
	E14	/	Indoor fan motor malfunction	Indoor PCB
Indoor motor				
Outdoor Malfunction	F1	2	IPM protection	Power module
				Refrigerant
	F2	24	Instantaneous over-current protection of the compressor	Power module
				Refrigerant compressor
	F3	4	Communication error between Power module and main PCB board.	Power module
				Outdoor PCB
	F4	8	Compressor discharging temperature protection	Outdoor PCB
				discharge sensor
F6	12	outdoor ambient sensor failure	outdoor ambient sensor	
F7	11	Suction temperature sensor failure	Suction temperature sensor	
			outdoor PCB	

ERROR CODE		OUTDOOR (LED FLASH TIMES)	FAULT DESCRIPTION	SPARE PART
	F8	9	DC fan motor malfunction	outdoor PCB
				outdoor motor
	F9	26	Module reset	Power module
				Outdoor PCB
	F11	18	Loss of synchronism detection	compressor
				The wiring of compressor
F12	1	EEPROM failure	Power module	
Outdoor Malfunction	F13	16	Lack of refrigerant	Outdoor PCB
	F14	17	4-way valve reverse failure	Refrigerant
	F19	6	Power over/under voltage protection	4-way valve
	F20	5	High pressure protection	Power module
				Outdoor pipe temperature sensor
	F21	10	Outdoor coil temperature sensor	Outdoor PCB
	F22	3	Outdoor Alternating current over current protection	Defrost temperature sensor
				Power module
				Refrigerant
	F23	25	Compressor U-phase overcurrent Compressor V-phase overcurrent Compressor W-phase overcurrent	compressor
				Power module
				Refrigerant
	F24	27	CT detection current abnormal protection	compressor
				Power module
	F25	13	Abnormal of compressor discharge sensor	Power module
discharge sensor				
F27	7	Compressor current sampling circuit fault	Outdoor PCB	
			Power module	
			compressor	
F28	19	Compressor position detection circuit fault	Outdoor PCB	
			Power module	
			compressor	
F35	38	Compressor driver board failure	Power module	
			Outdoor PCB	
			Compressor	
F43	46	Model matching abnormality	/	
Fixed frequency AC	FE	/	Refrigerant leaking detection malfunction	Refrigerant

10.4.1 Thermistor or Related Abnormality

- Indoor Display E1: Room temperature sensor failure
 E2: Heat-exchange sensor failure
- Outdoor display LED1 flash 10 times : Defrost temperature sensor failure
 LED1 flash 11 times : Suction temperature sensor failure
 LED1 flash 12 times : Ambient temperature sensor failure
 LED1 flash 13 times : Discharge temperature sensor failure

- Method of Malfunction Detection
- Malfunction Decision Conditions
- Supposed Causes
- Trouble shooting

The temperatures detected by the thermistors are used to determine thermistor errors

When the thermistor input is more than 4.92V or less than 0.08V during compressor operation.

- Note: The values vary slightly in some models

- Faulty connector connection
- Faulty thermistor
- Faulty PCB

* Caution: Be sure to turn off power switch before connect or disconnect connector, or else parts damage may be occurred.

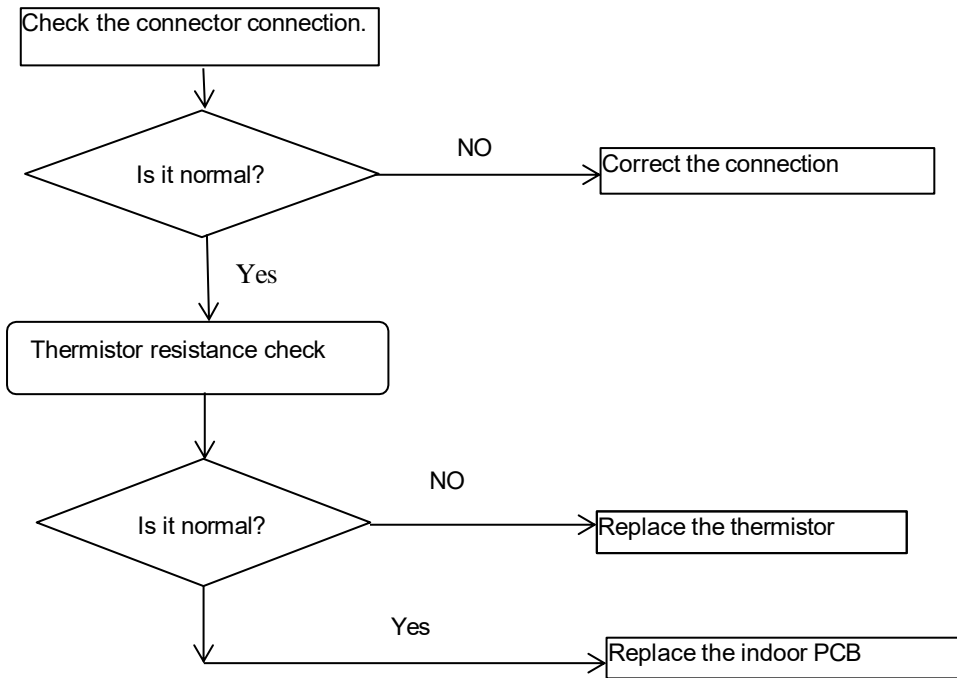

Thermistor resistance inspection method:

Remove the connector of the thermistor on the PCB, and measure the resistance of thermistor using tester. The relationship between normal temperature and resistance is shown in the value of indoor thermistor.

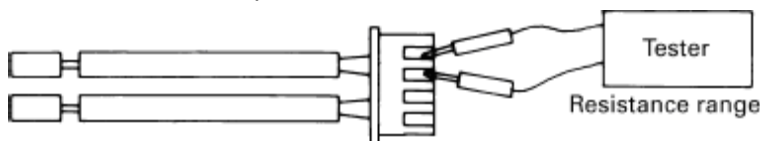

10.4.2 EEPROM abnormal

Indoor Display
Indoor display

E4: Indoor EEPROM error
F12: Outdoor EEPROM error; Outdoor LED1 flash 1 times

Method of
Malfunction
Detection

The Data detected by the EEPROM are used to determine MCU

Malfunction
Decision
Conditions

When the data of EEPROM is error or the EEPROM is damaged

Supposed
Causes

- Faulty EEPROM data
- Faulty EEPROM
- Faulty PCB

Trouble
shooting

* Caution: Be sure to turn off power switch before connect or disconnect connector, or parts damage may be occurred.

Replace the indoor or outdoor mainboard.

10.4.3 Indoor DC fan motor malfunction

Indoor Display

E14 Indoor DC fan motor malfunction

Method of Malfunction Detection

When the fan motor is running, the speed detected by the Hall IC is used to judge the abnormal operation of the fan motor

Malfunction Decision Conditions

When the detected rotation feedback signal don't received in 2 minutes

Supposed Causes

- Operation halt due to breaking of wire inside the fan motor.
- Operation halt due to breaking of the fan motor lead wires
- Detection error due to faulty indoor unit PCB

Trouble shooting

* Caution: Be sure to turn off power switch before connect or disconnect connector, or else parts damage may be occurred.

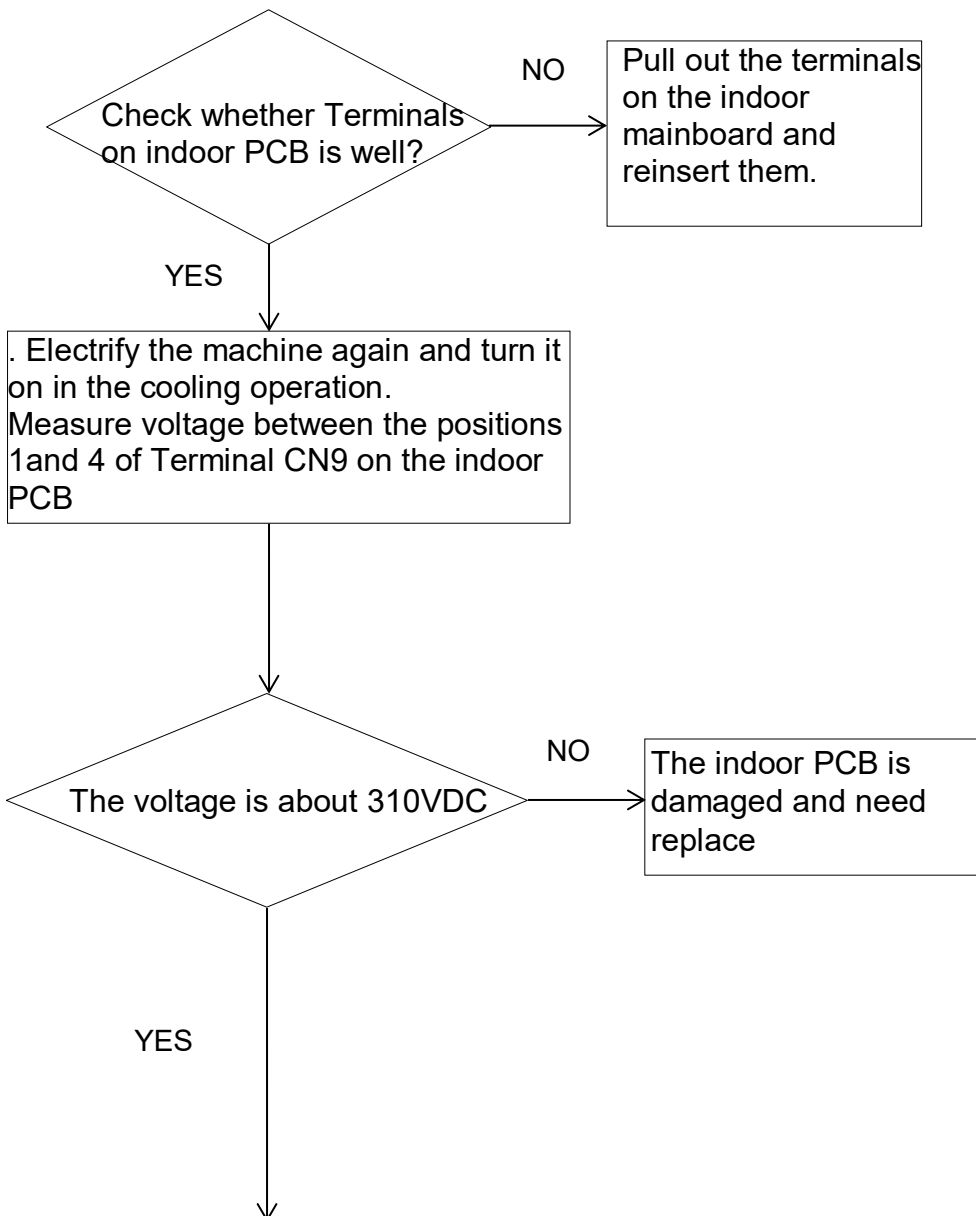

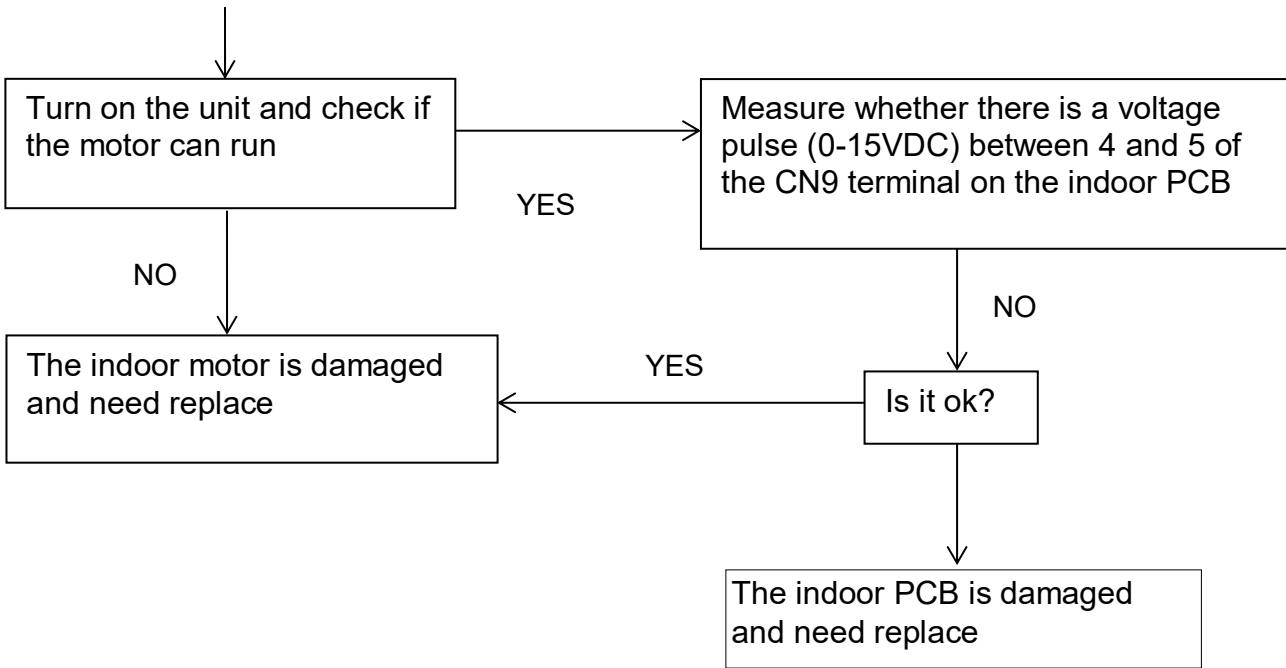

	Color	Signal	Voltage
1	Red	VDC	310V
2	---	---	---
3	---	---	---
4	Black	GND	0V
5	White	VCC	15v
6	Blue	FG	15V
7	Yellow	Vsp	0-6.5V



10.4.4 Outdoor DC fan motor fault

Outdoor display F8 LED1 flash 9 times

Method of Malfunction Detection

DC fan motor is detected by checking the fan running condition and so on

Malfunction Decision Conditions

When the detected rotation feedback signal don't received in 2 minutes

Supposed Causes

- DC fan motor protection dues to the DC fan motor faulty
- DC fan motor protection dues to faulty PCB

Trouble shooting

* Caution: Be sure to turn off power switch before connect or disconnect connector, or else parts damage may be occurred.

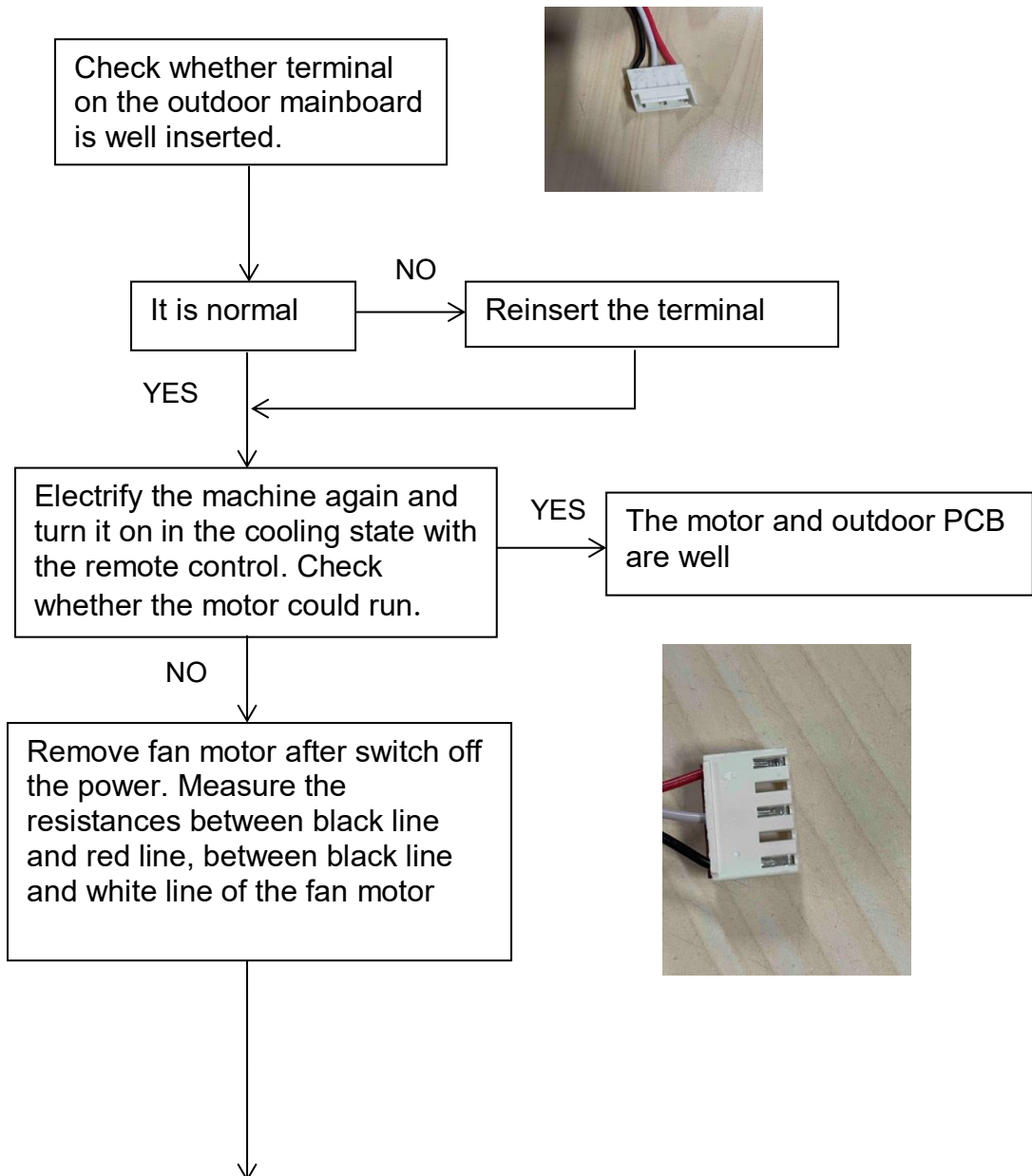

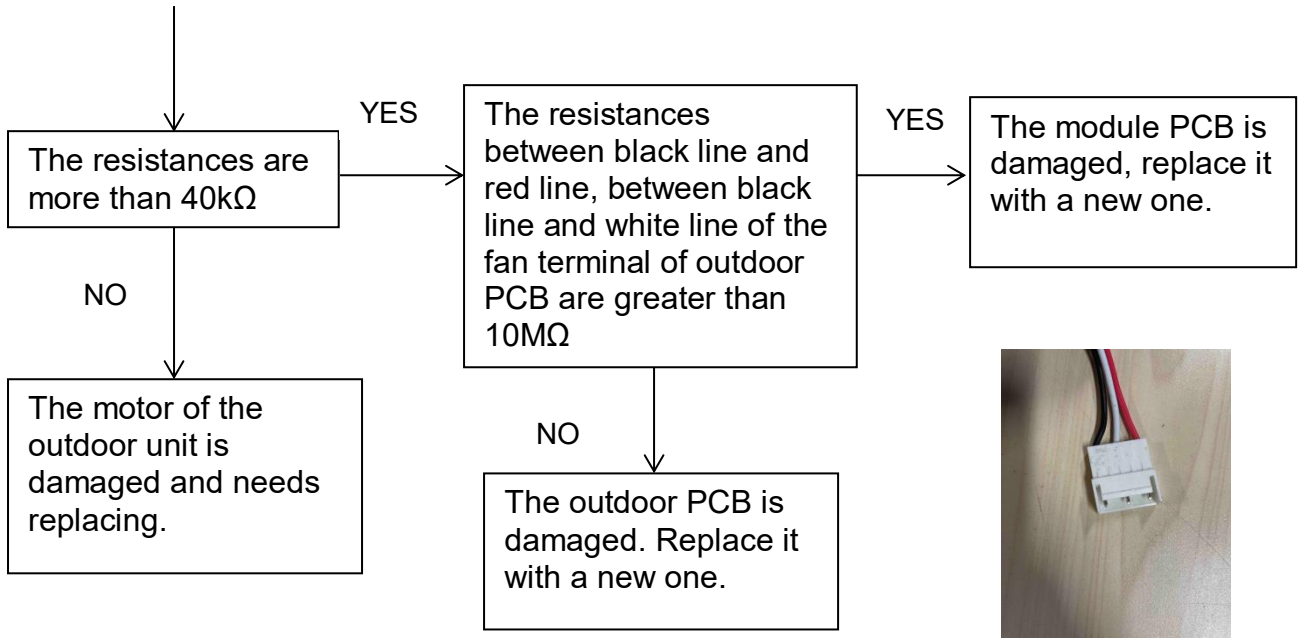

10.4.5 IPM protection

Outdoor display: F1 LED1 flash 2 times

Method of Malfunction Detection	IPM protection is detected by checking the compressor running condition and so on
Malfunction Decision Conditions	The system leads to IPM protection due to over current The compressor faulty leads to IPM protection Circuit component of IPM is broken and led to IPM protection
Supposed Causes	<ul style="list-style-type: none"> ■ IPM protection dues to the compressor faulty ■ IPM protection dues to faulty PCB of IPM module ■ Compressor wiring disconnected
Trouble shooting	* Caution: Be sure to turn off power switch before connect or disconnect connector, or else parts damage may be occurred

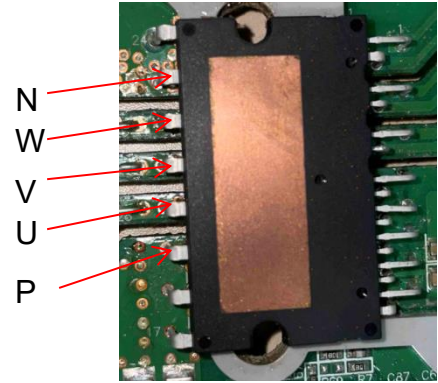
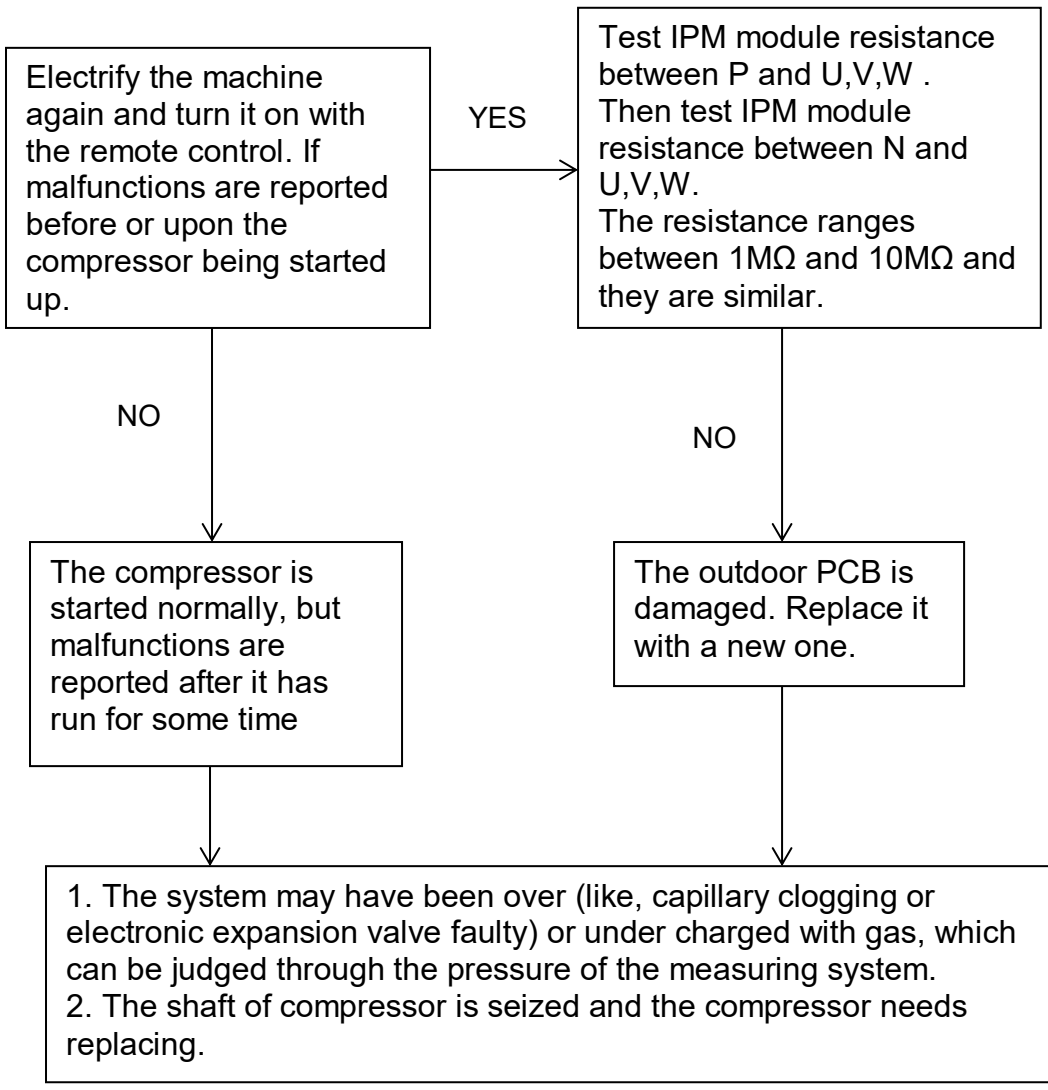

10.4.6 Over-current of the compressor

Outdoor Display F22, F2, F23 LED1 flash 3 or 24 or 25 times

Method of Malfunction Detection	The current of the compressor is too high
Malfunction Decision Conditions	When the IPM Module is damaged or the compressor is damaged. Power supply voltage is too low or too high
Supposed Causes	<ul style="list-style-type: none"> ■ Faulty IPM Module ■ Faulty compressor ■ Faulty power supply
Trouble shooting	* Caution: Be sure to turn off power switch before connect or disconnect connector, or parts damage may be occurred.

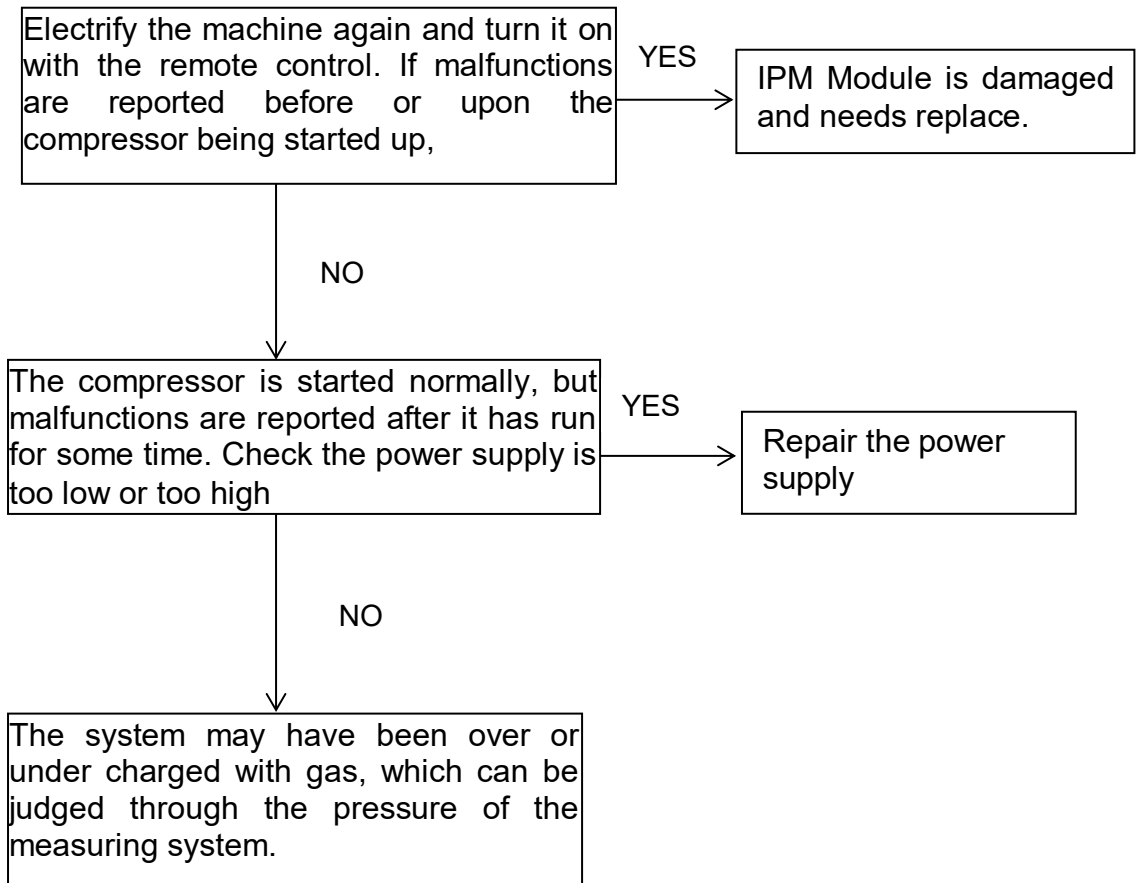

10.4.7 The communication fault between IPM and outdoor PCB

Outdoor display:	F3 LED1 flash 4 times
Method of Malfunction Detection	Communication is detected by checking the IPM module and the outdoor PCB
Malfunction Decision Conditions	<ul style="list-style-type: none"> ■ The outdoor PCB broken leads to communication fault ■ The IPM module broken leads to communication fault
Supposed Causes	<ul style="list-style-type: none"> ■ The outdoor PCB is broken ■ The IPM module is broken ■ Communication wiring disconnected
Trouble shooting	* Caution: Be sure to turn off power switch before connect or disconnect connector, or else parts damage may be occurred.

Check whether the CN23 and CN24 terminals of the outdoor PCB and the CN10 and CN11 terminals of the IPM module are tightly connected.
 Check whether the connection between the power module and the outdoor P&N line is tight

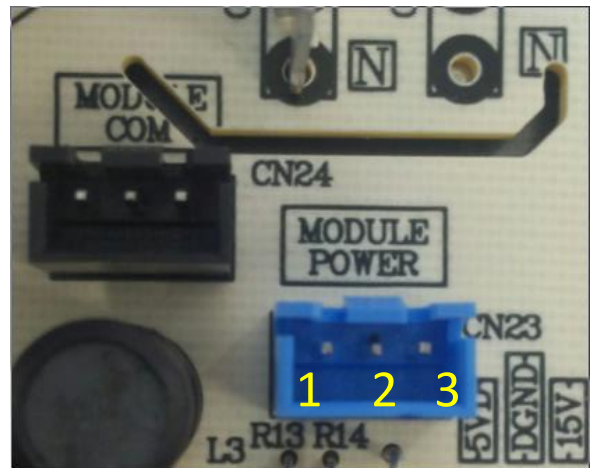
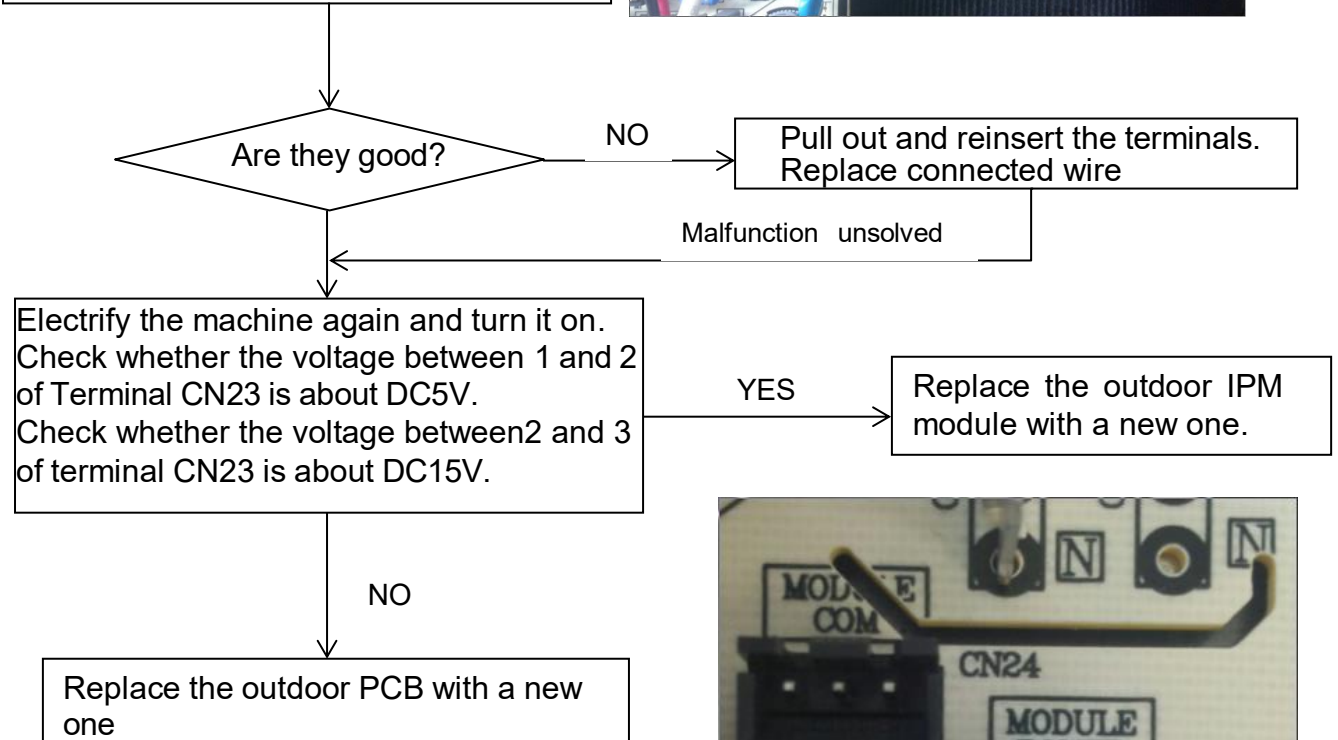
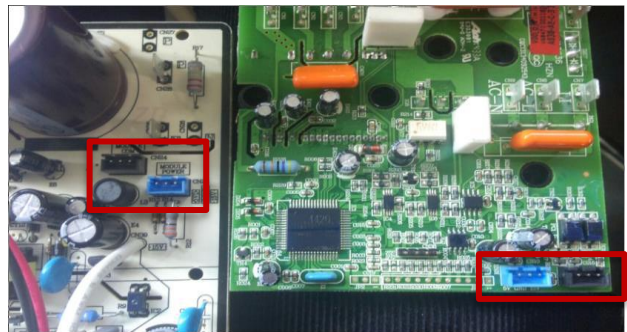

10.4.8 Power Supply Over or under voltage fault

Outdoor display: F19 LED1 flash 6 times

Method of Malfunction Detection: An abnormal voltage rise or fall is detected by checking the specified voltage detection circuit. The power supply is over voltage

Malfunction Decision Conditions: The voltage signal is fed from the voltage detection circuit to the microcomputer

- Supposed Causes
- Supply voltage not as specified
 - the IPM module is broken
 - the outdoor PCB is broken

Trouble shooting: * Caution: Be sure to turn off power switch before connect or disconnect connector, or else parts damage may be occurred.

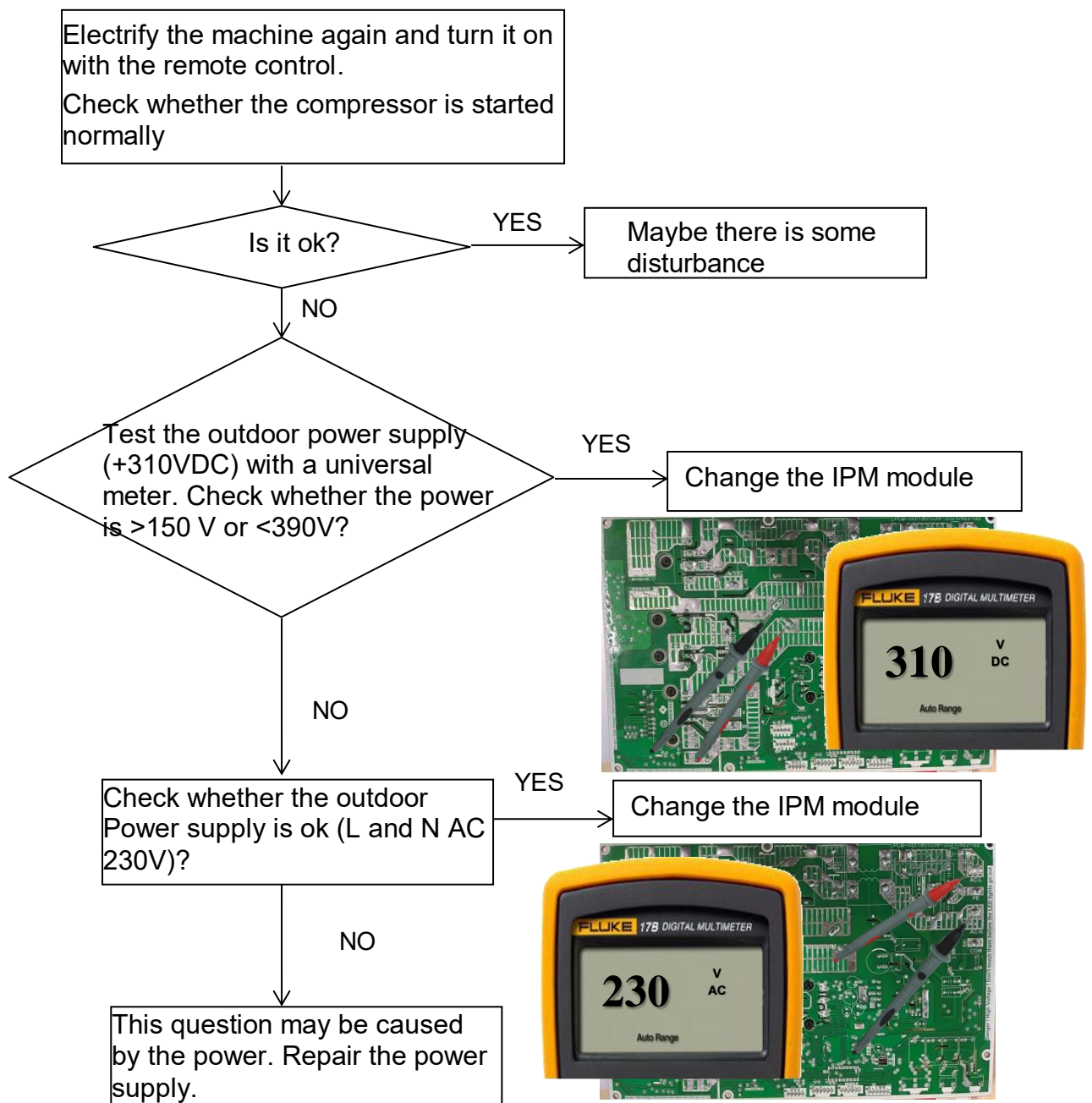

10.4.9 Overheat Protection for Discharge Temperature

Outdoor display: F4 LED1 flash 8 times

Method of Malfunction Detection	Check the control of the discharge temperature by the temperature detected by the discharge pipe thermistor
Malfunction Decision Conditions	When the compressor discharge temperature is above 110°C
Supposed Causes	<ul style="list-style-type: none"> ■ Electronic expansion valve defective ■ Faulty thermistor ■ Faulty PCB
Trouble shooting	* Caution: Be sure to turn off power switch before connect or disconnect connector or else parts damage may be occurred.

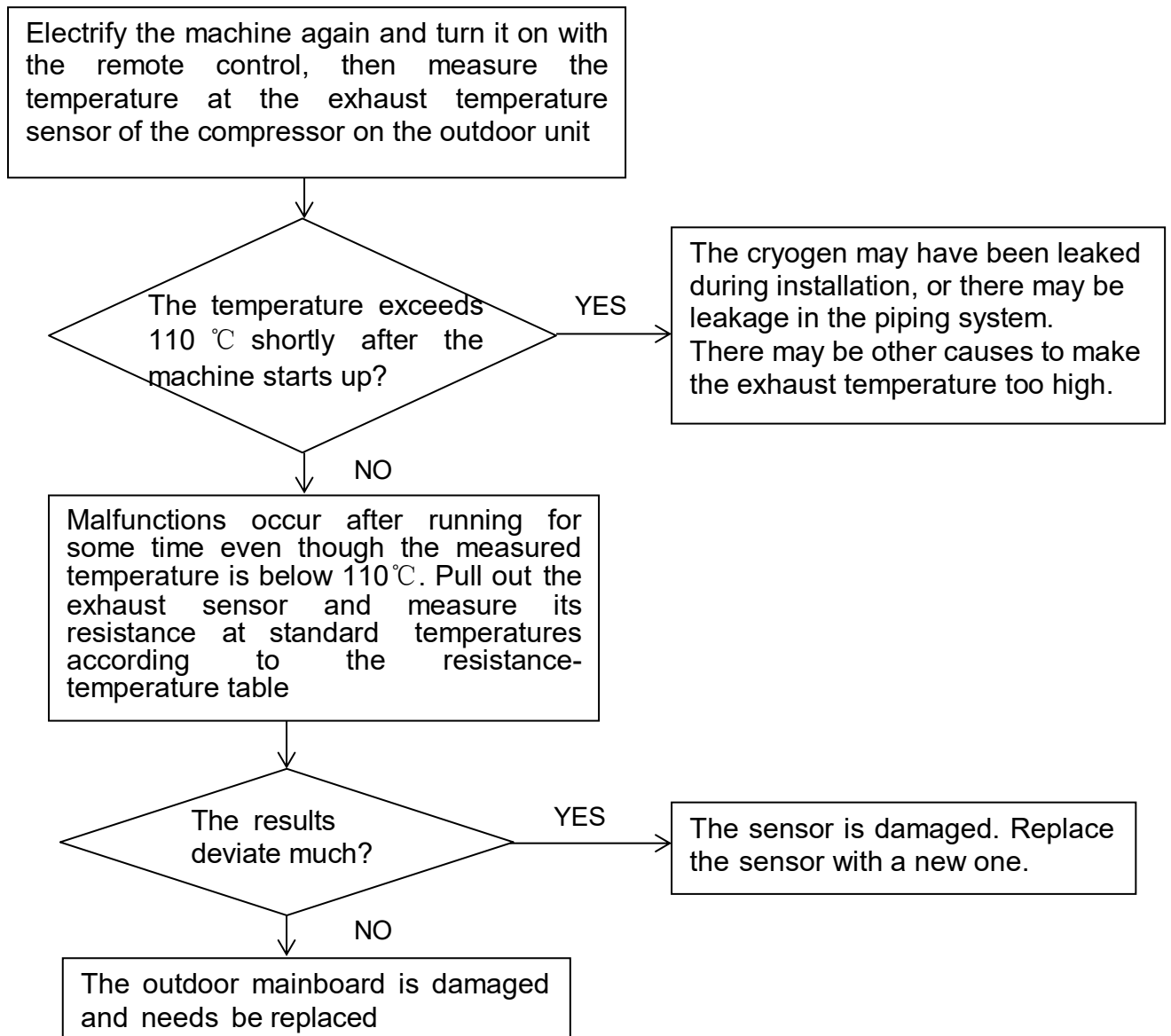

10.4.10 The communication fault between indoor and outdoor

Split board Indoor display E7 outdoor display LED1 flash 15 times

Method of Malfunction Detection	Communication is detected by checking the indoor PCB and the outdoor PCB.
Malfunction Decision Conditions	The outdoor PCB broken leads to communication fault. The indoor PCB broken leads to communication fault.
Supposed Causes	<ul style="list-style-type: none"> ■ Communication wiring disconnected. ■ The indoor PCB is broken. ■ The outdoor PCB is broken. ■ The Power Module is broken.
Trouble shooting	* Caution: Be sure to turn off power switch before connect or disconnect connector, or else parts damage may be occurred.

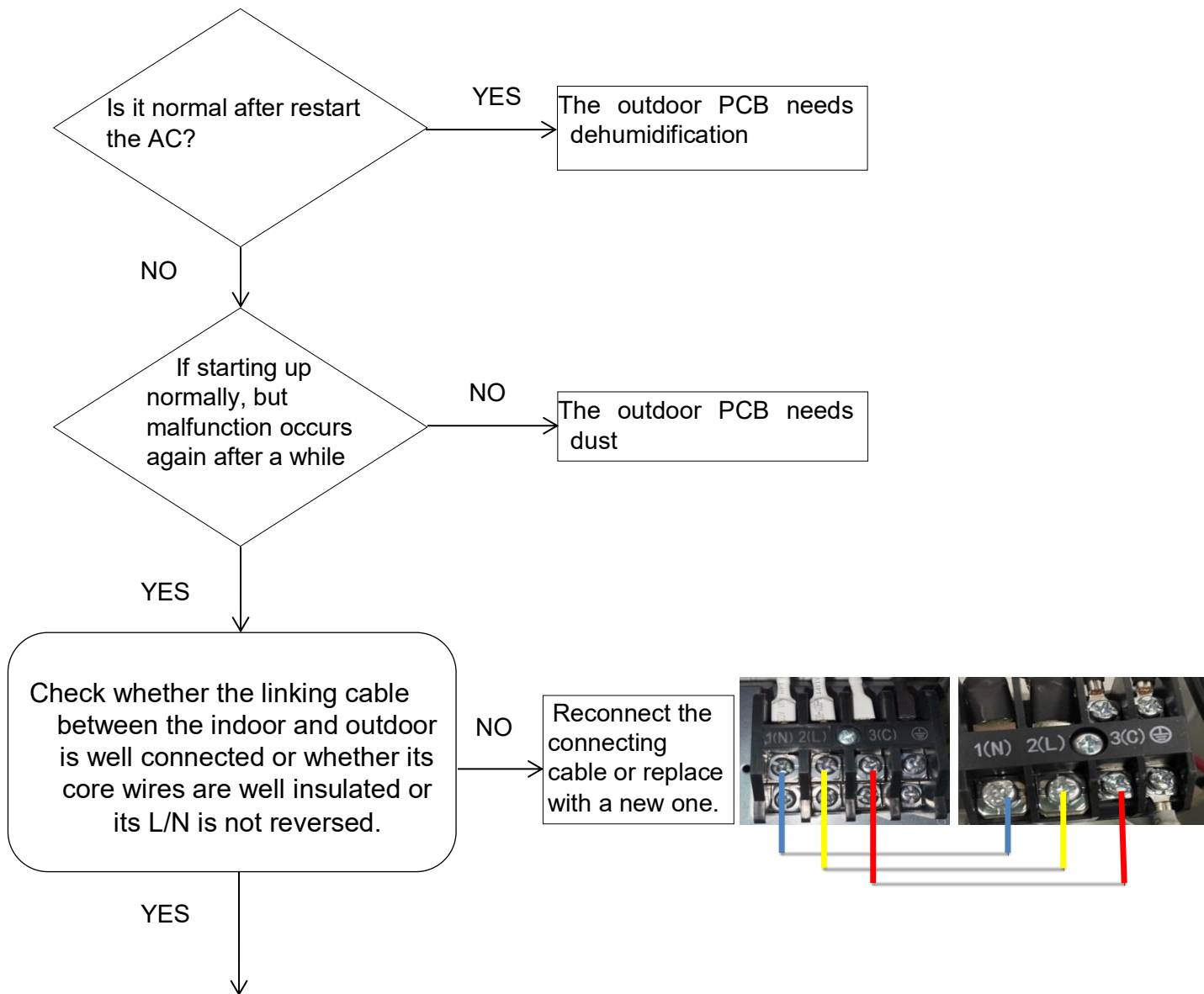

Check the indoor PCB: only indoor charged measure the voltage between 3 and 4 of IC6 on the indoor PCB with a universal meter. And measure the voltage between CN23(S) and CN17 (L) with a universal meter.

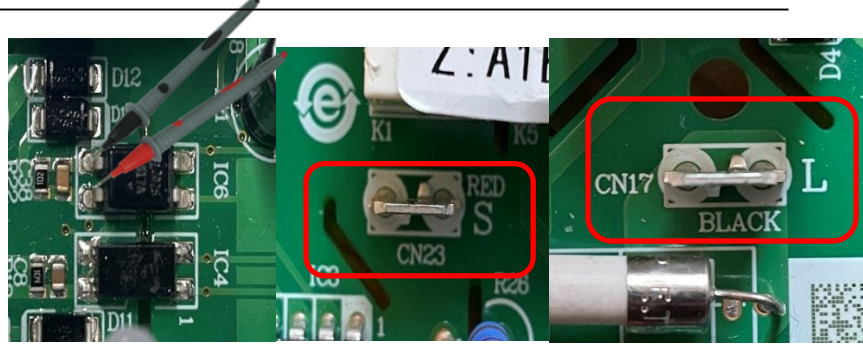

If the voltage is a constant value from DC 0V to DC 5V. Or the voltage between communication line (red) and N (white line) is not close to 18V DC when only indoor charged.

YES → The indoor PCB is damaged; replace it with a new one.

NO ↓

Test the outdoor power is supply 230VAC with a universal meter when indoor and outdoor are charged.

NO → Check the cable between outdoor and power



YES ↓

LED2 light of the outdoor

NO → The module PCB is damaged. Replace it with a new one.

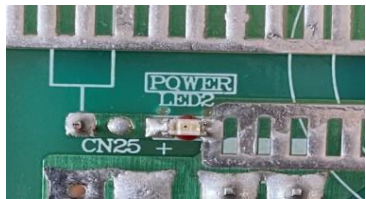

YES ↓

LED 1 light

YES → Measure the voltage between 3 and 4 of IC9 on the Outdoor mainboard with a universal meter. The voltage is a constant value of 0V DC to 5V DC

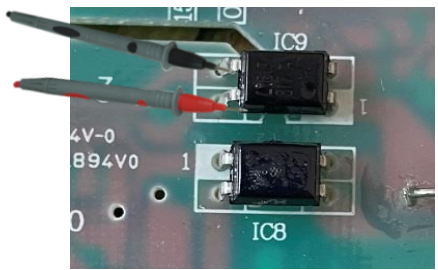

YES → The outdoor PCB is damaged. Replace it with a new one.

NO → Outdoor PCB is ok then check cable.

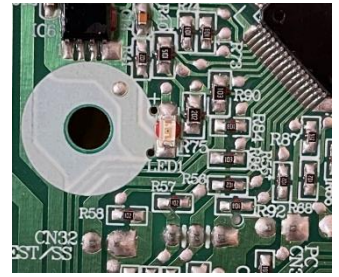
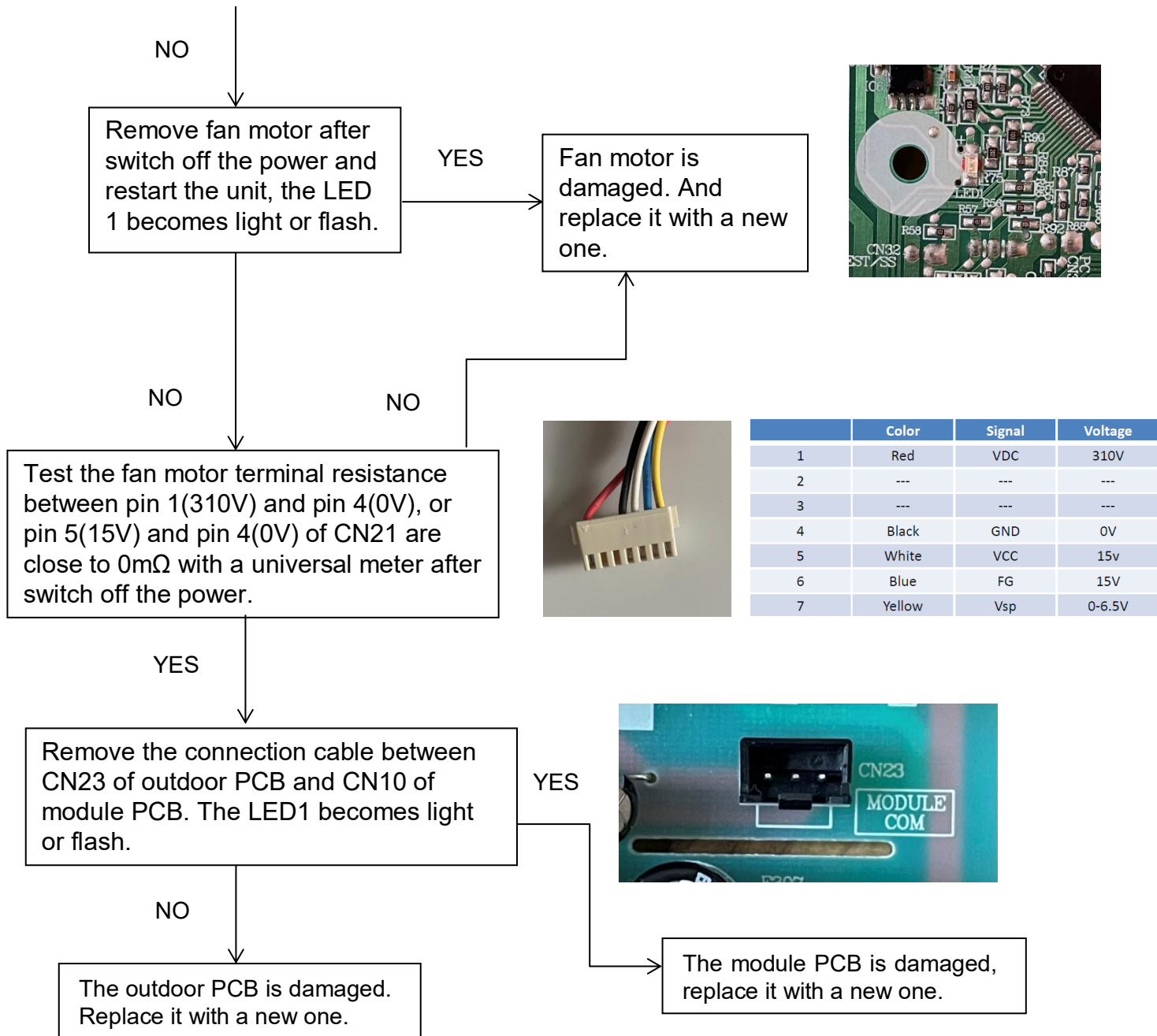

All-in-one board Indoor display E7 outdoor display LED2 flash 15 times

Method of Malfunction Detection	Communication is detected by checking the indoor PCB and the outdoor PCB.
Malfunction Decision Conditions	<ul style="list-style-type: none"> ■ The outdoor PCB broken leads to communication fault. ■ The indoor PCB broken leads to communication fault.
Supposed Causes	<ul style="list-style-type: none"> ■ Communication wiring disconnected. ■ The indoor PCB is broken. ■ The outdoor PCB is broken.
Trouble shooting	* Caution: Be sure to turn off power switch before connect or disconnect connector, or else parts damage may be occurred.

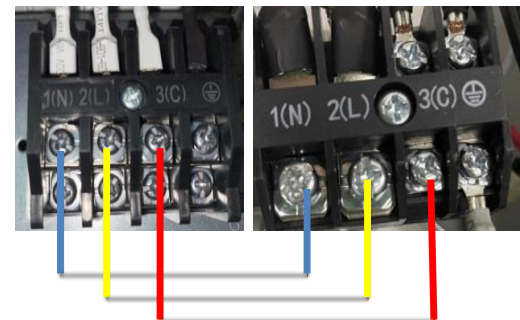
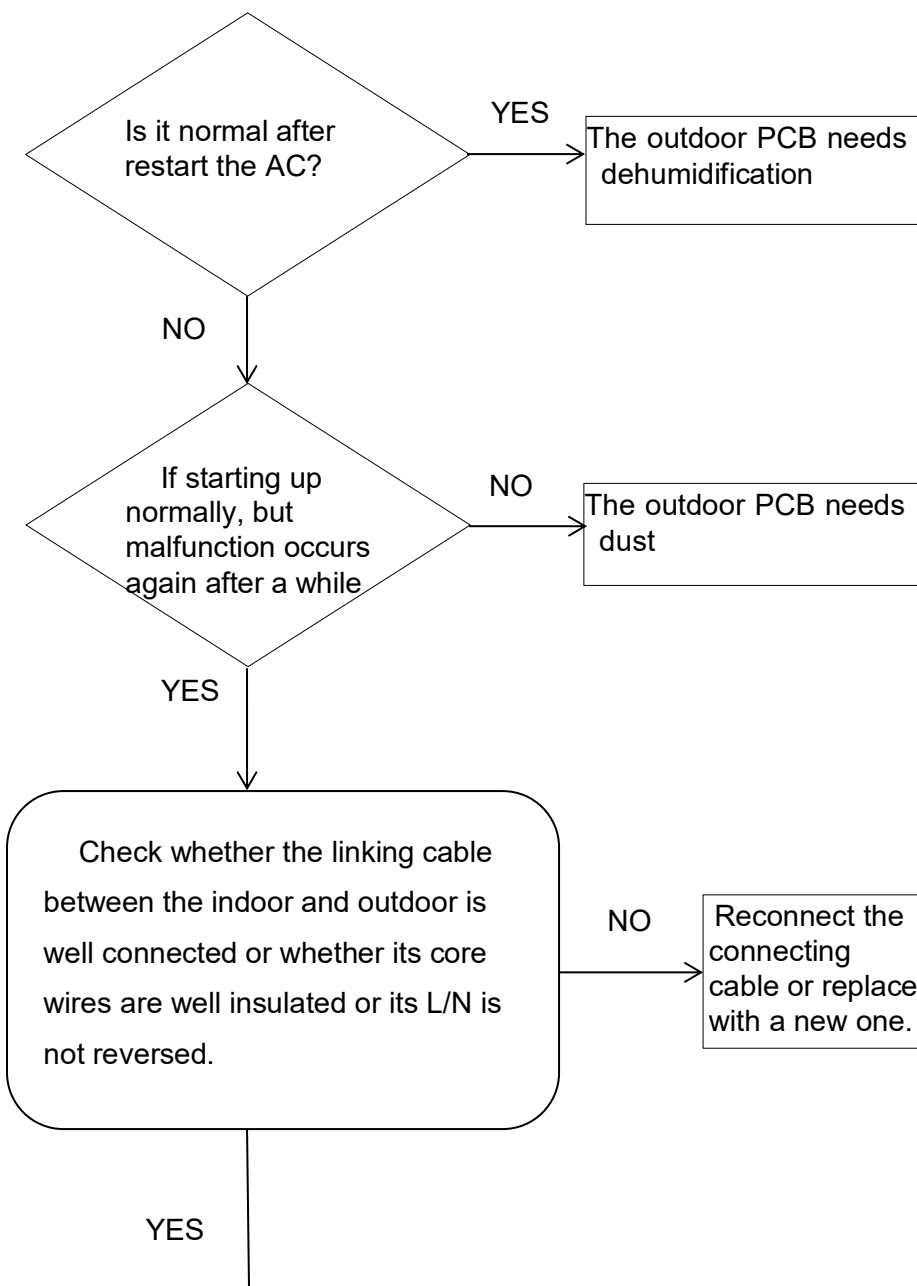

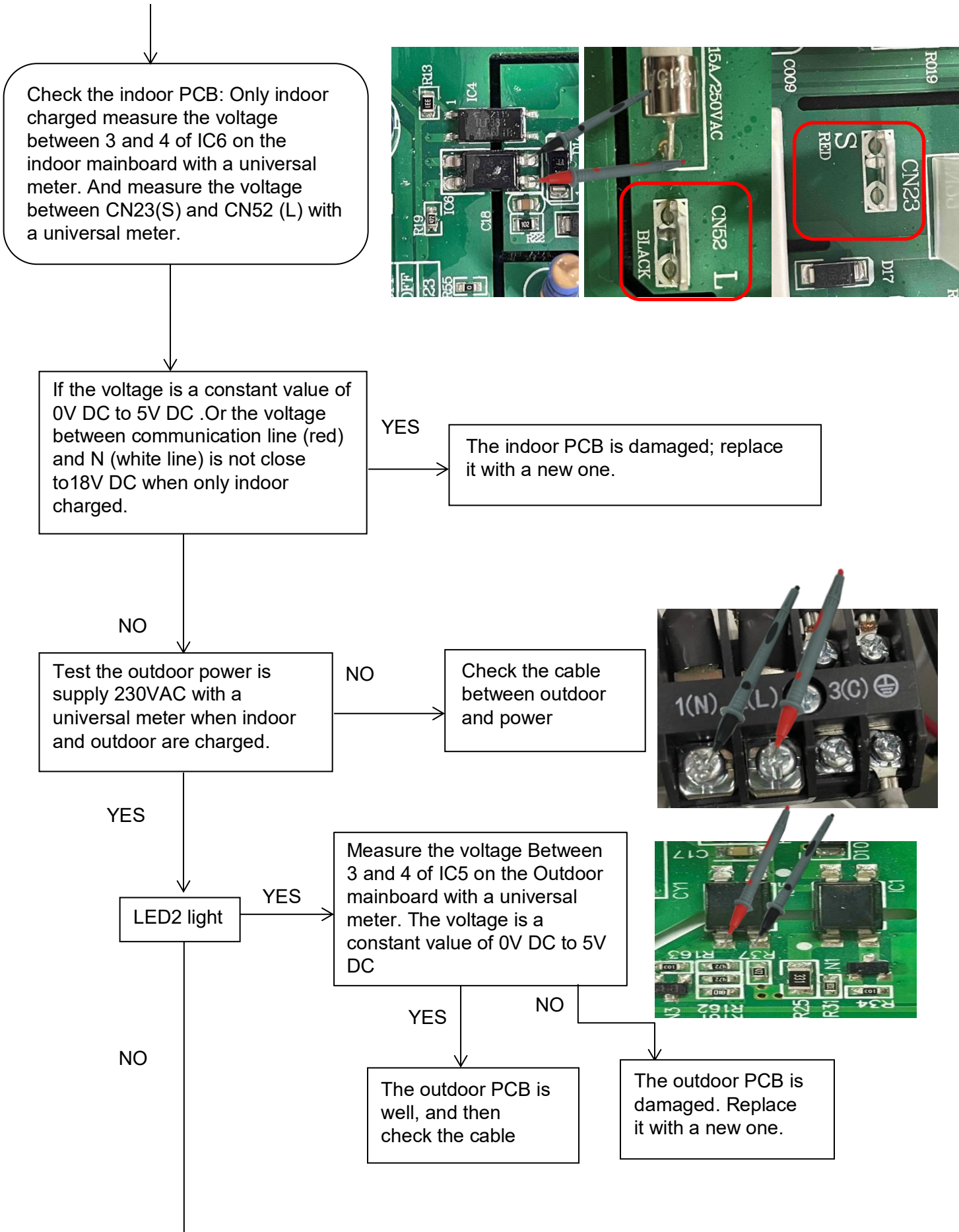

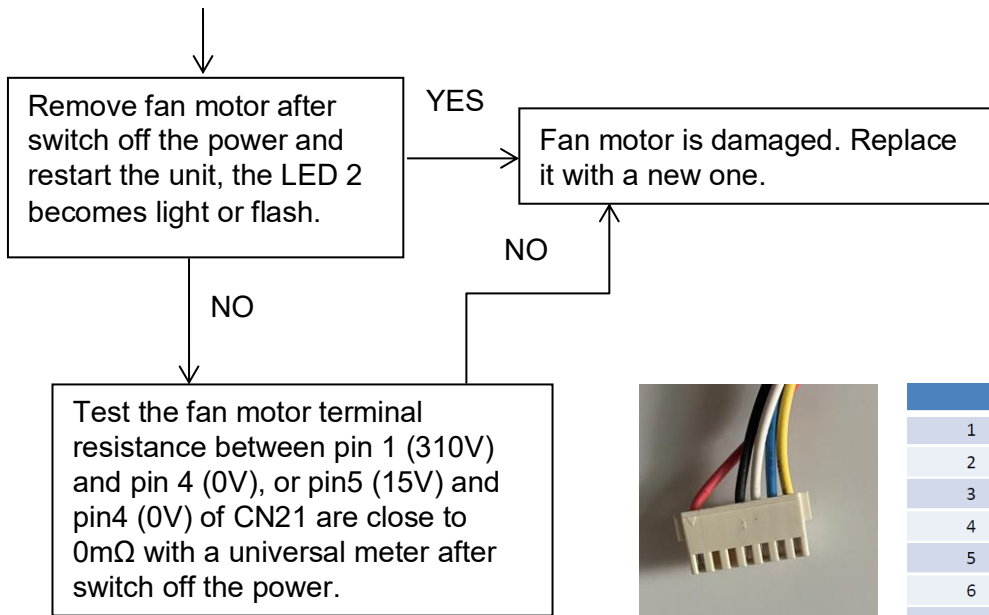

	Color	Signal	Voltage
1	Red	VDC	310V
2	---	---	---
3	---	---	---
4	Black	GND	0V
5	White	VCC	15v
6	Blue	FG	15V
7	Yellow	Vsp	0-6.5V

10.4.11 Loss of synchronism detection (Compressor position detection circuit fault)

Outdoor Display	F11 LED1 flash 18 times F28 LED1 flash 19 times
Method of Malfunction Detection	The position of the compressor rotor can't detected normally
Malfunction Decision Conditions	When the wiring of compressor is wrong or the connection is poor; Or the compressor is damaged
Supposed Causes	<ul style="list-style-type: none"> ■ Faulty The wiring of compressor ■ Faulty compressor ■ Faulty PCB
Trouble shooting	* Caution: Be sure to turn off power switch before connect or disconnect connector, or parts damage may be occurred.

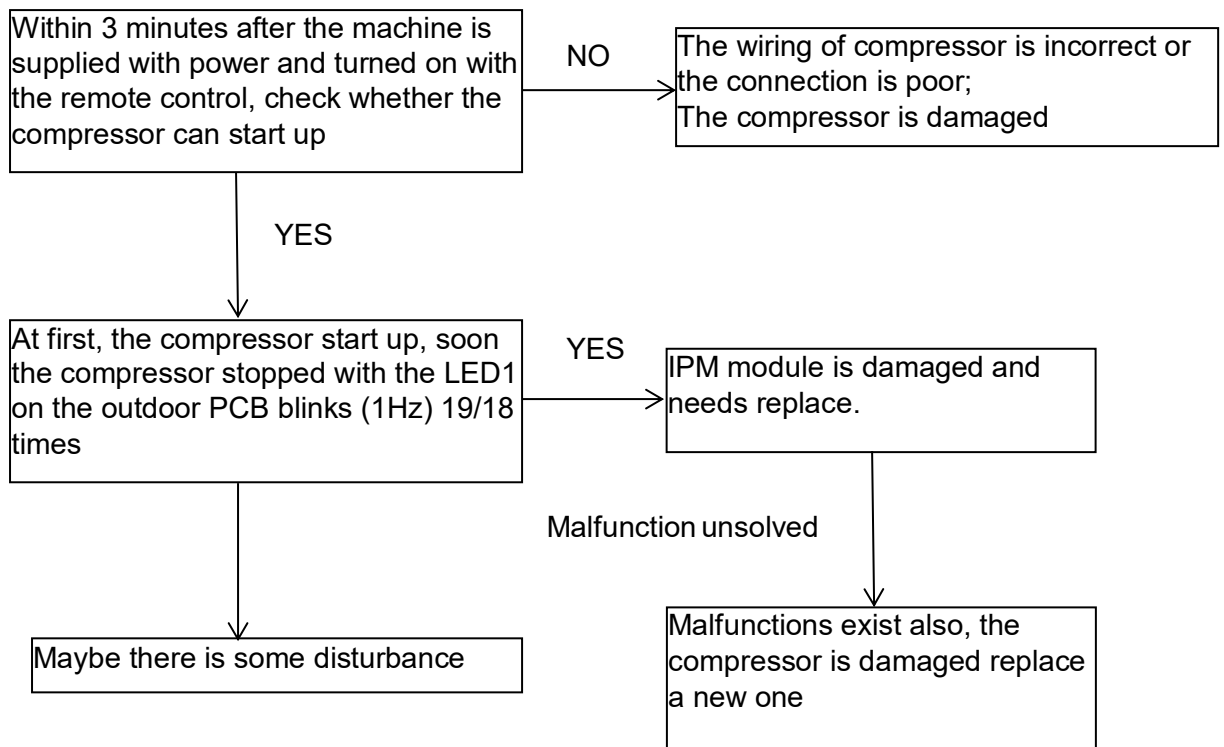

10.4.12 High work-intense protection

Outdoor display	E 9 LED1 flash 21 times
Method of Malfunction Detection	High work-intense control is activated in the heating mode if the temperature being sensed by the heat exchanger thermistor exceeds the limit.
Malfunction Decision Conditions	Activated when the temperature being sensed by the heat exchanger rises above 65°C twice in 30 minutes
Supposed Causes	<ul style="list-style-type: none"> ■ Faulty electronic expansion valve ■ Dirty heat exchanger ■ Faulty heat-exchange sensor ■ Insufficient gas
Trouble shooting	<p>* Caution: Be sure to turn off power switch before connect or disconnect connector, or parts damage may be occurred.</p>

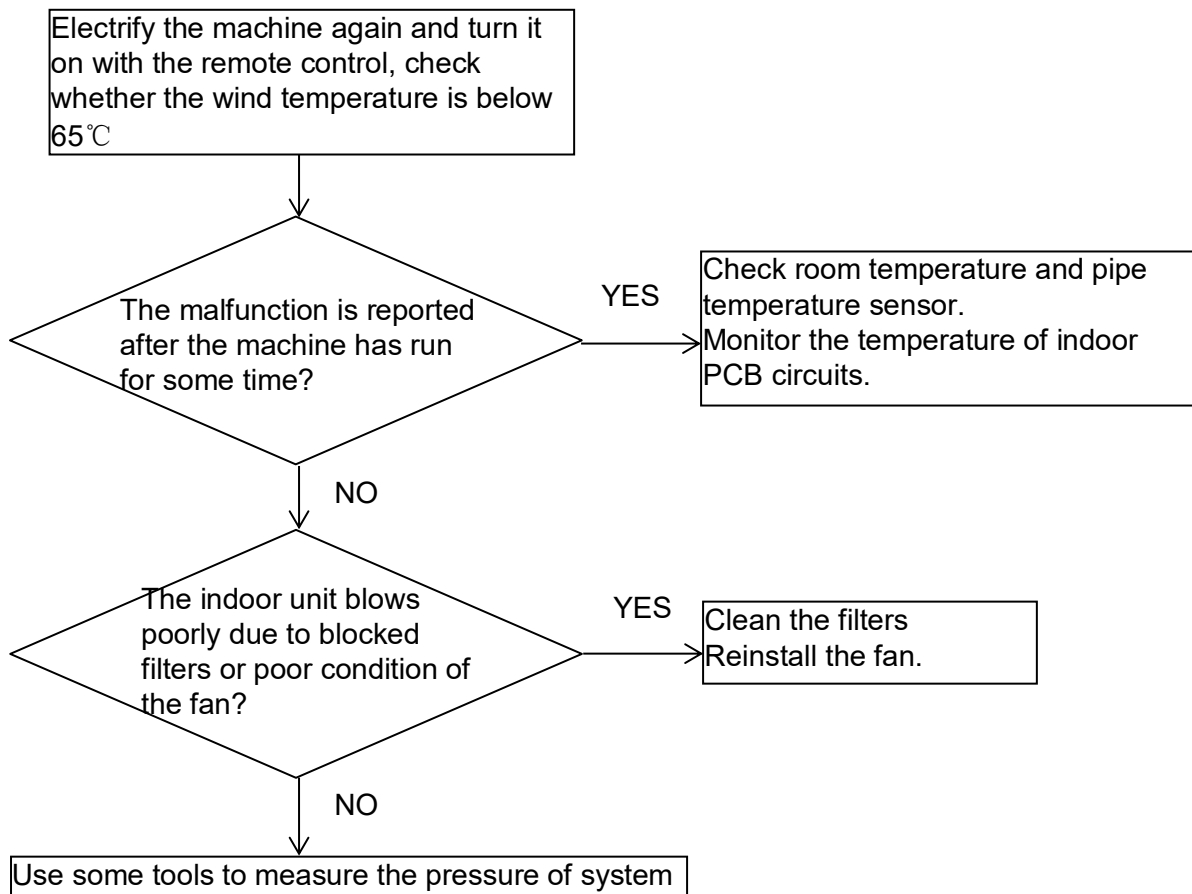

11 Performance and curves diagrams

11.1 Cooling capacity temperature curves

AS71PEGHRA-1U71XAGFRA performance curves									
cooling capacity and indoor/outdoor temp. table									
indoor temp.	outdoor temp								
DB/WB	12°C	15°C	20°C	25°C	30°C	35°C	40°C	43°C	53°C
21/15°C	6787	6642	6400	6053	6394	6669	6455	6361	5642
24/16°C	7235	7079	6820	6449	6813	7109	6879	6778	6092
27/19°C	7635	7470	7196	6802	7188	7597	7257	7151	6434
30/22°C	7688	7522	7246	6849	7238	7553	7308	7201	6492
32/23°C	7855	7685	7403	6997	7395	7717	7466	7356	6632
35/26°C	8001	7972	7679	7256	7670	8006	7745	7631	6803

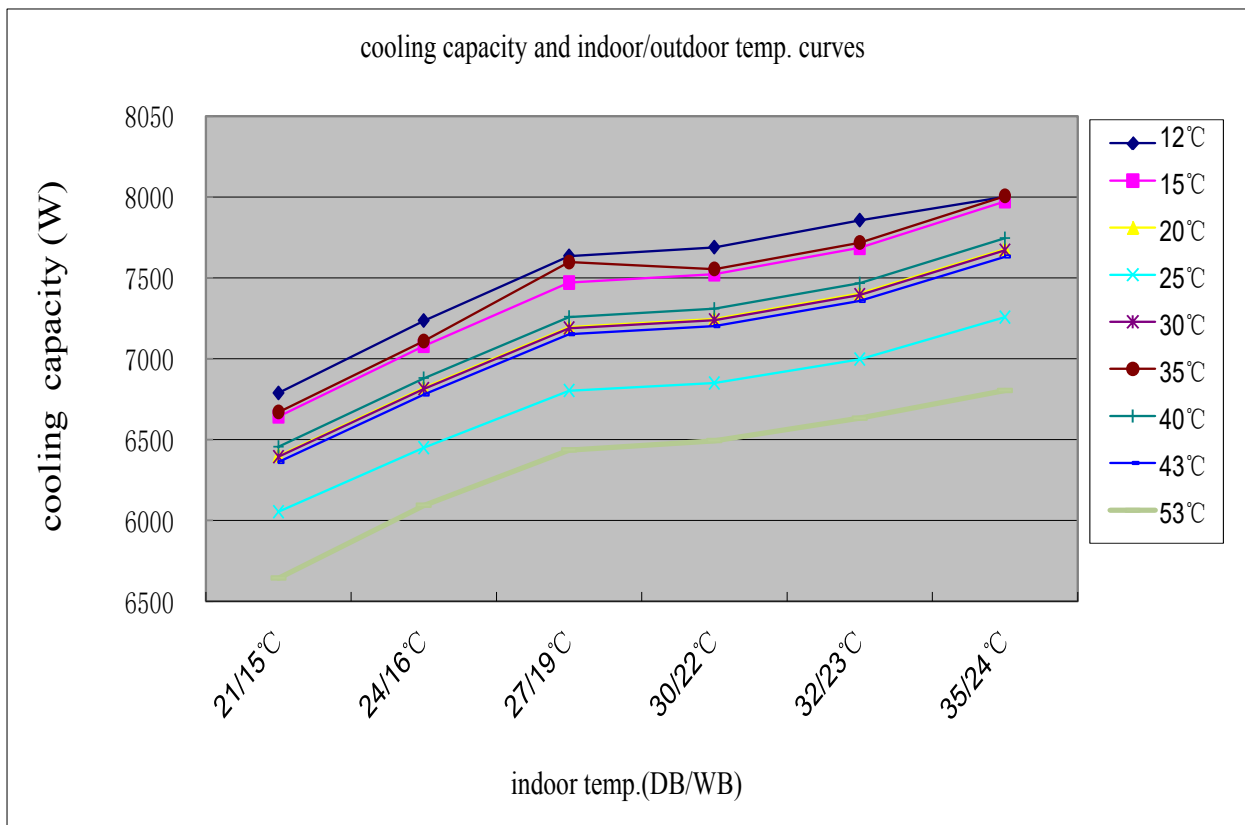

11.2 Power consumption temperature curves

AS71PEGHRA-1U71XAGFRA performance curves									
power consumption and indoor/outdoor temp. table									
indoor temp.	outdoor temp.								
DB/WB	12°C	15°C	20°C	25°C	30°C	35°C	38°C	40°C	43°C
21/15°C	1697	1792	1862	1964	2047	1998	2092	2164	2204
24/16°C	1763	1841	1911	2006	2109	2054	2141	2206	2246
27/19°C	1832	1887	1940	2027	2151	2111	2191	2263	2303
30/22°C	1894	1945	2019	2099	2213	2168	2281	2339	2379
32/23°C	1940	2006	2076	2158	2274	2263	2396	2479	2519
35/24°C	1978	2068	2175	2285	2336	2319	2434	2541	2577

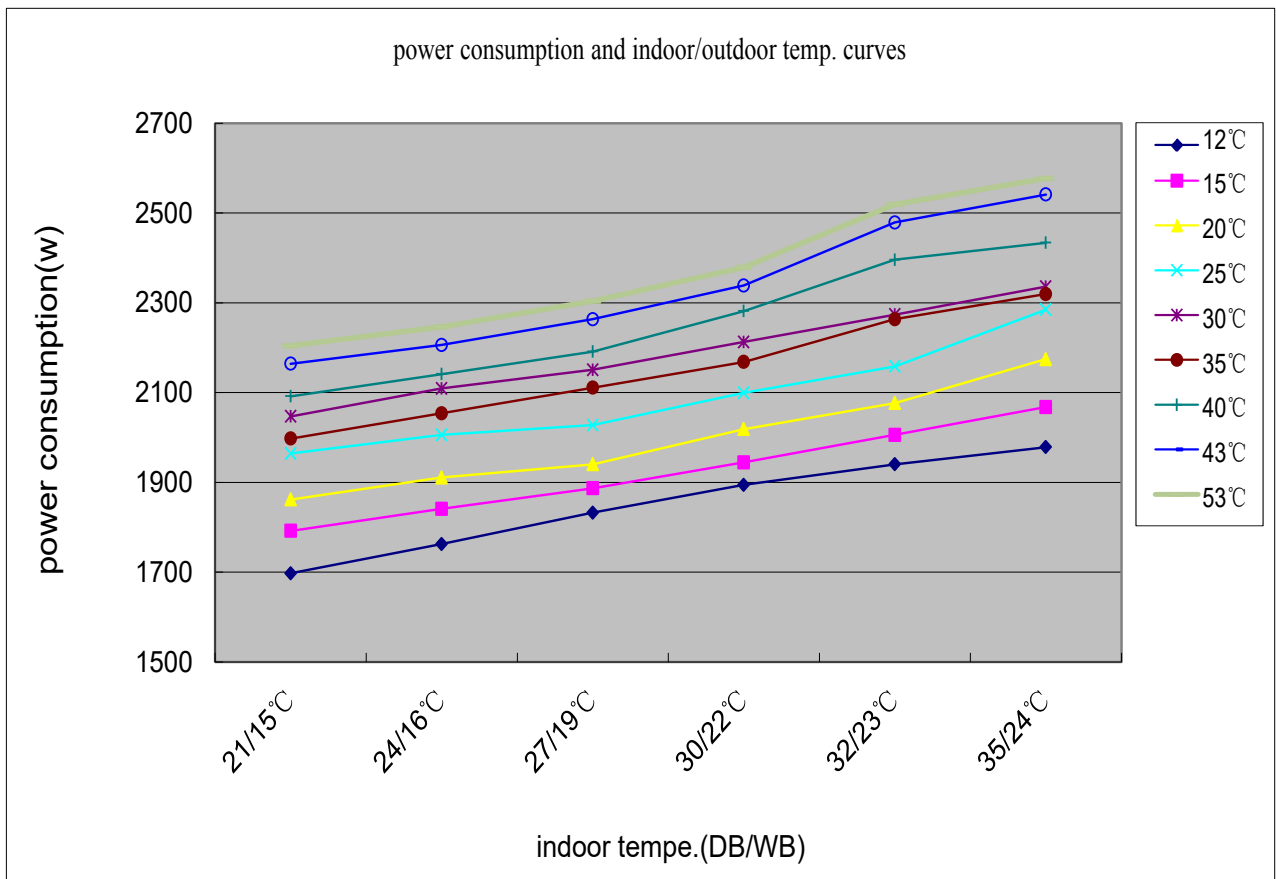

11.3 Heating capacity temperature curves

AS71PEGHRA-1U71XAGFRA performance curves				
heating capacity and indoor/outdoor temp. table				
outdoor temp.	indoor temp.(humidity 46%)			
DB/WB	10°C	15°C	20°C	27°C
-20°C	4684	4437	4226	3929
-15°C	5246	5008	4773	4458
-10°C	6179	5910	5592	5138
-7/-8°C	7142	6832	6508	6139
2/1°C	7871	7708	7393	7090
7/6°C	8205	8027	7760	7394
12/11°C	7733	7531	7156	6863
18/16°C	6501	6249	6042	5718
24/20°C	5358	5115	4878	4596

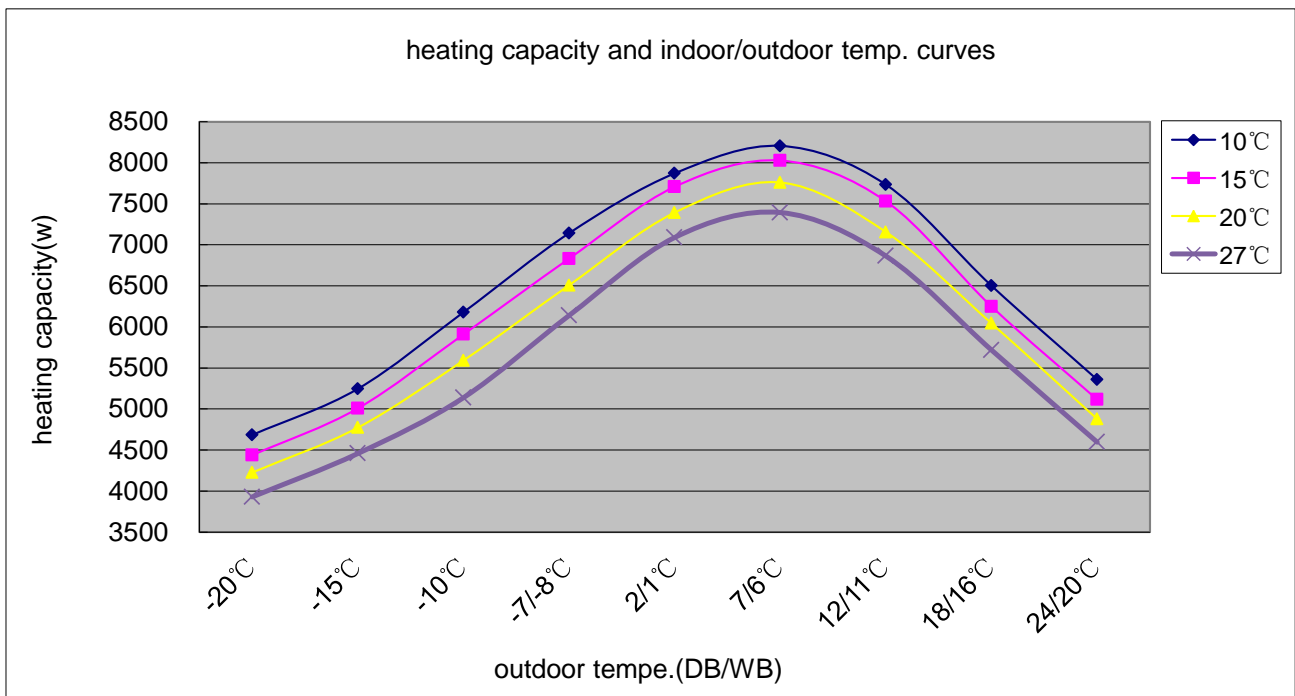

11.4 Power consumption value-temperature curves

AS71PEGHRA-1U71XAGFRA performance curves				
power consumption and indoor/outdoor temp. table				
outdoor temp.	indoor temp.(humidity 46%)			
DB/WB	10°C	15°C	20°C	27°C
-20°C	3042	3103	3199	3278
-15°C	2981	3035	3114	3204
-10°C	2762	2843	2925	3017
-7/-8°C	2452	2549	2624	2729
2/1°C	2124	2252	2362	2429
7/6°C	1908	2012	2120	2174
12/11°C	1707	1781	1888	1956
18/16°C	1505	1578	1678	1742
24/20°C	1326	1390	1485	1563

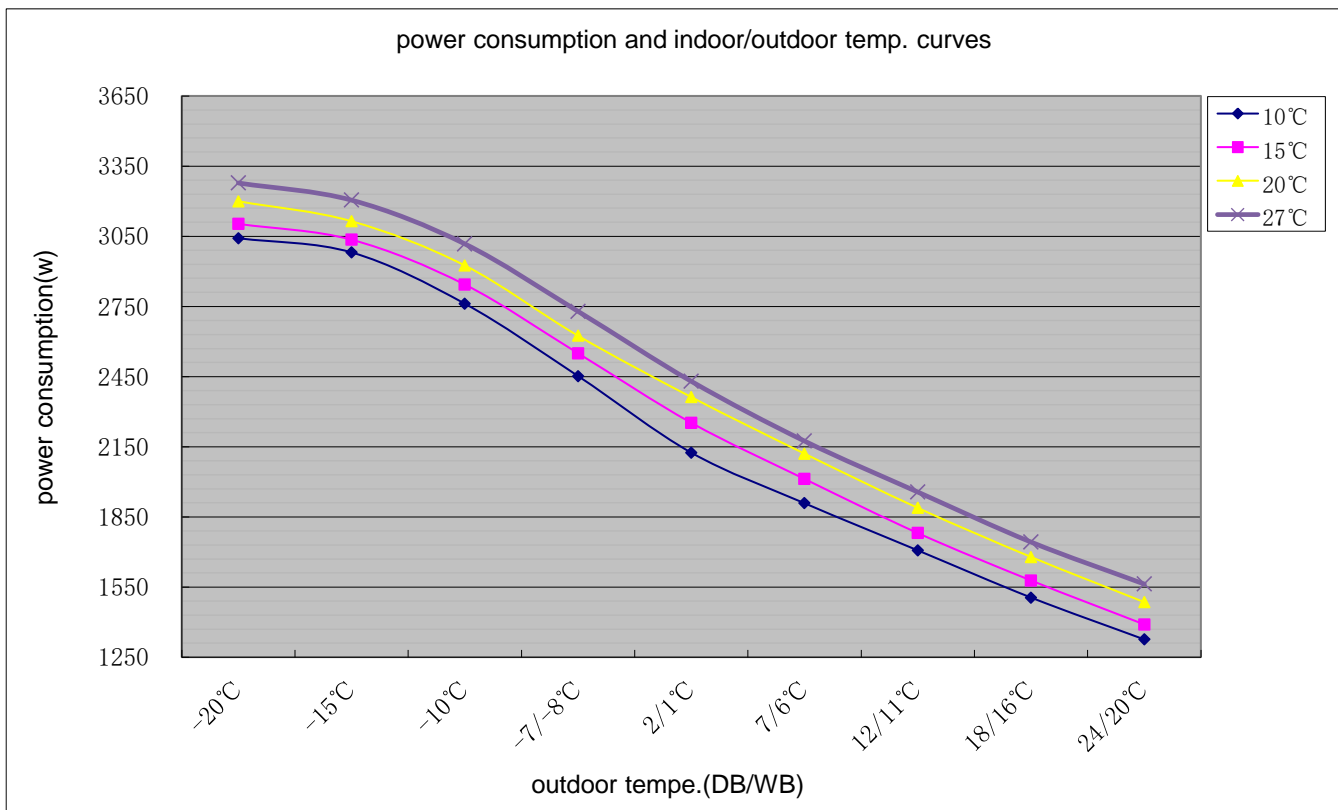

11.5 Cooling discharge pressure curves

AS71PEGHRA-1U71XAGFRA performance curves			
cooling discharge pressure and indoor/outdoor temp. table			
outdoor temp. (humidity 46%)	indoor temp.		
DB/WB	21/15°C	27/19°C	35/24°C
10°C	1968	2029	2150
15°C	2017	2053	2176
20°C	2051	2105	2185
25°C	2173	2207	2251
30°C	2303	2407	2488
35°C	2486	2570	2725
38°C	2696	2760	2933
40°C	2964	3111	3272
43°C	3320	3517	3827

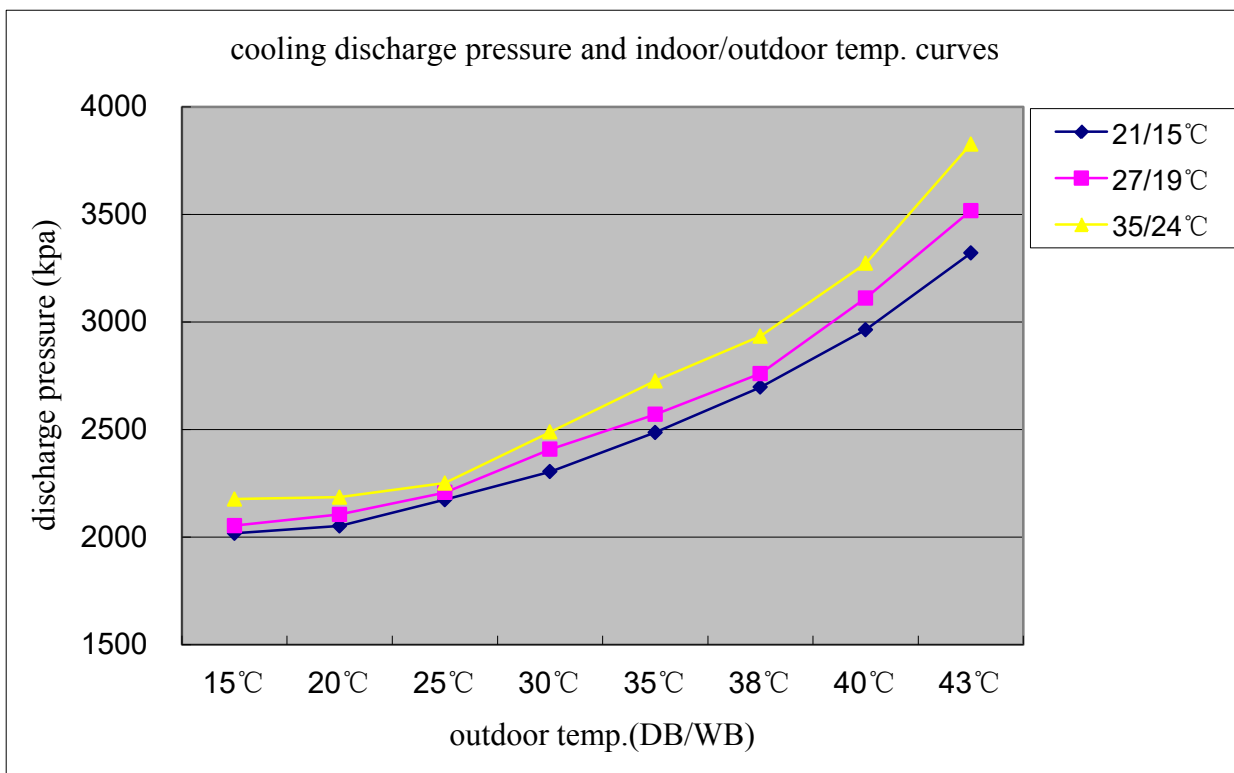

11.6 Cooling suction pressure curves

AS71PEGHRA-1U71XAGFRA performance curves			
cooling suction pressure and indoor/outdoor temp. table			
outdoor temp. (humidity 46%)	indoor temp.		
DB/WB	21/15°C	27/19°C	35/24°C
10°C	698	816	948
15°C	705	825	958
20°C	711	841	968
25°C	749	850	988
30°C	789	895	997
35°C	796	904	1050
38°C	839	932	1072
40°C	922	1025	1179
45°C	1015	1107	1285

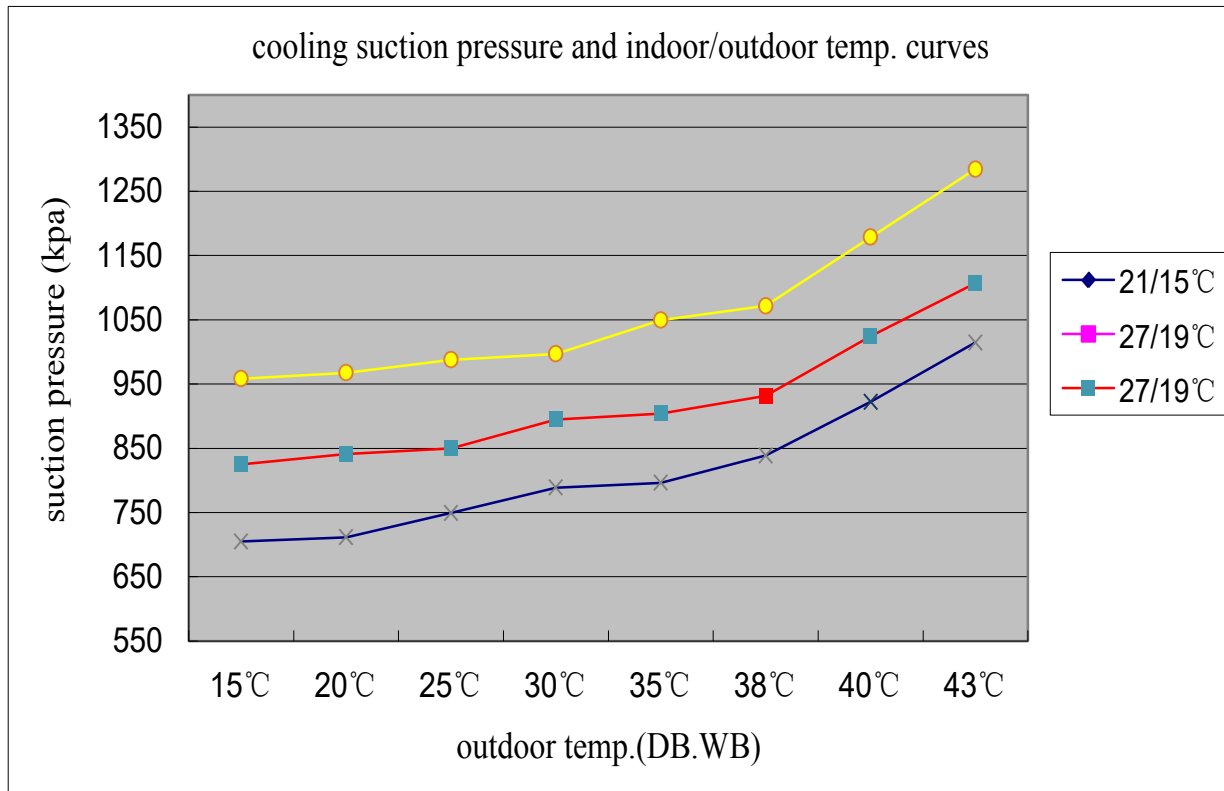

11.7 Heating discharge pressure curves

AS71PEGHRA-1U71XAGFRA performance curves			
heating discharge pressure and indoor/outdoor temp. table			
outdoor temp. (humidity 46%)	indoor temp.		
DB/WB	10°C	20°C	27°C
-15°C	2496	2653	2804
-10°C	2742	2861	3026
-7/-8°C	3155	3275	3372
2/1°C	3266	3550	3649
7/6°C	3318	3446	3576
12/11°C	3147	3343	3445
18/16°C	3007	3142	3182
24/20°C	2526	2671	2773

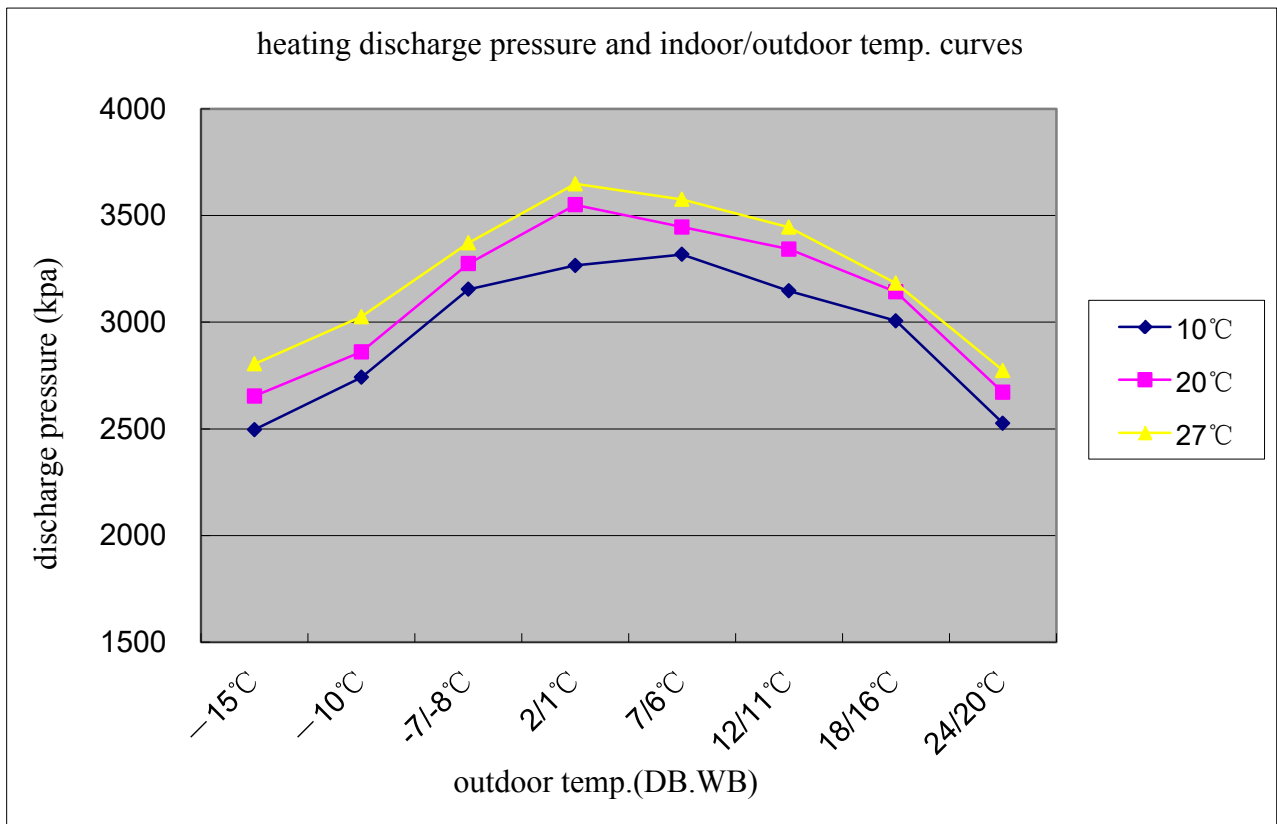

11.8 Heating suction pressure curves

AS71PEGHRA-1U71XAGFRA performance curves			
heating suction pressure and indoor/outdoor temp. table			
outdoor temp. (humidity 46%)	indoor temp.		
DB/WB	10°C	20°C	27°C
-15°C	345	385	405
-10°C	398	428	447
-7/-8°C	492	532	551
2/1°C	611	651	670
7/6°C	744	784	803
12/11°C	844	884	904
18/16°C	1011	1051	1071
24/20°C	1197	1237	1256

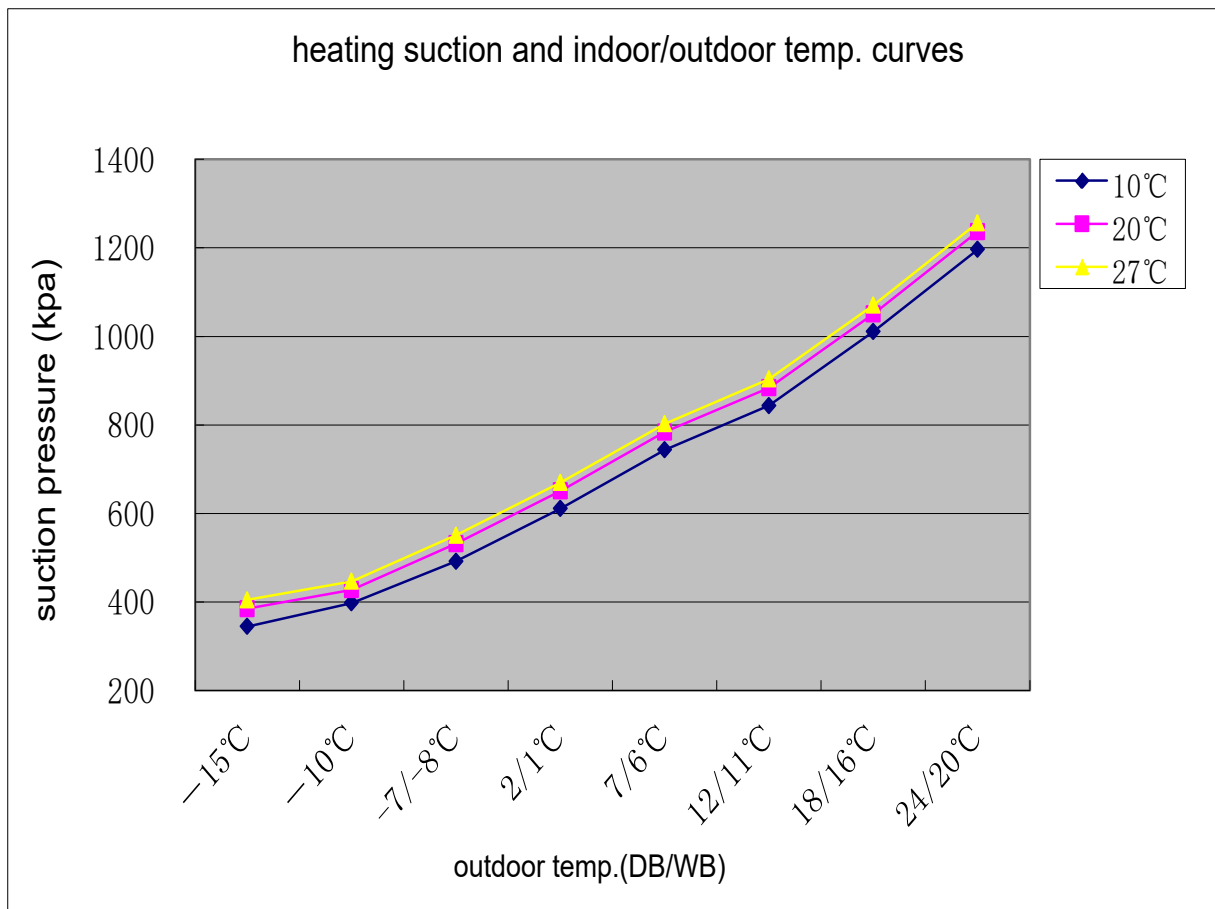

12 Wiring Diagrams

Outdoor unit control board circuit diagrams

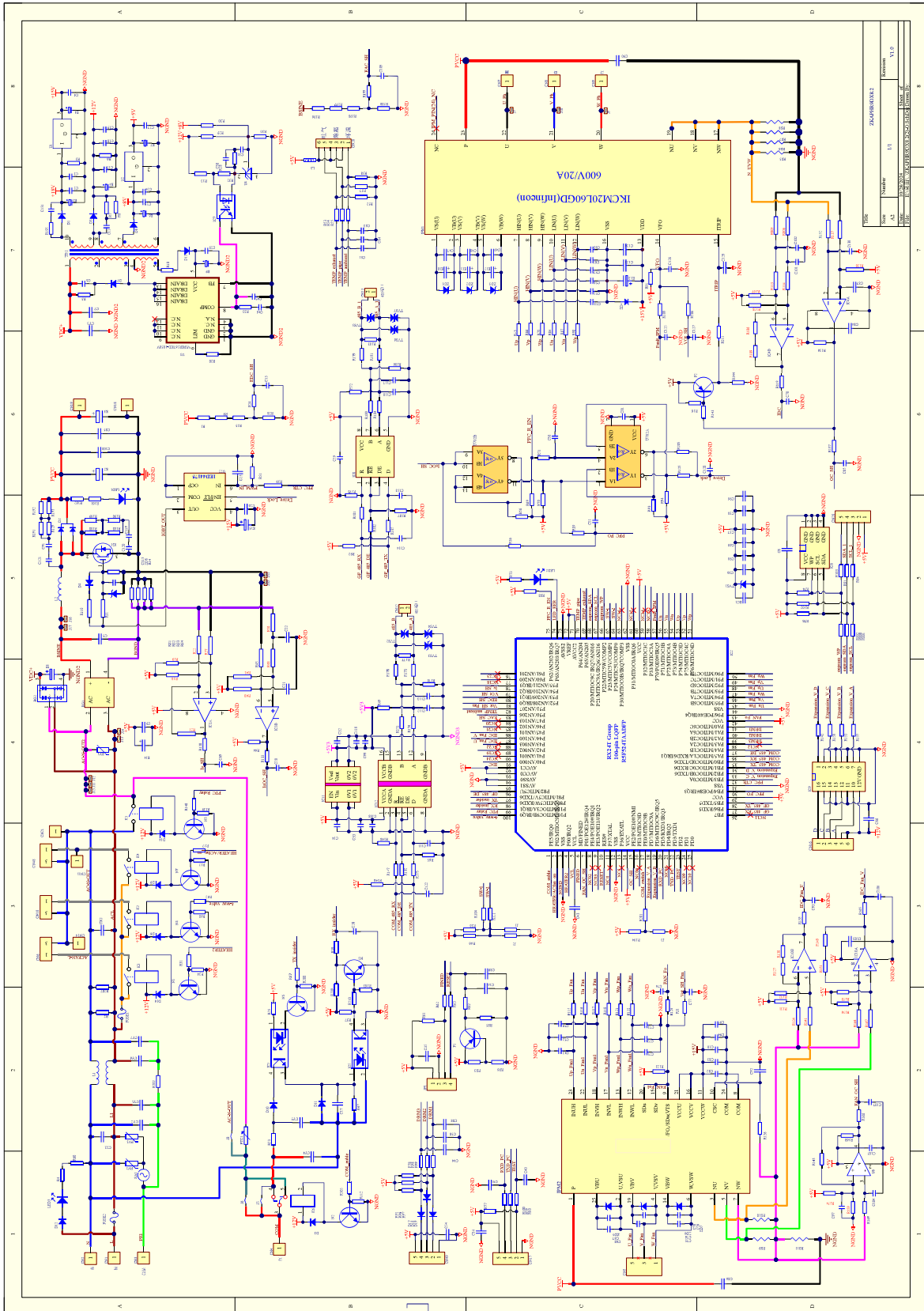

13 Removal of procedure

Procedure  **Warning** Be sure to wait 10 minutes or more after turning off all power supplies before disassembling work

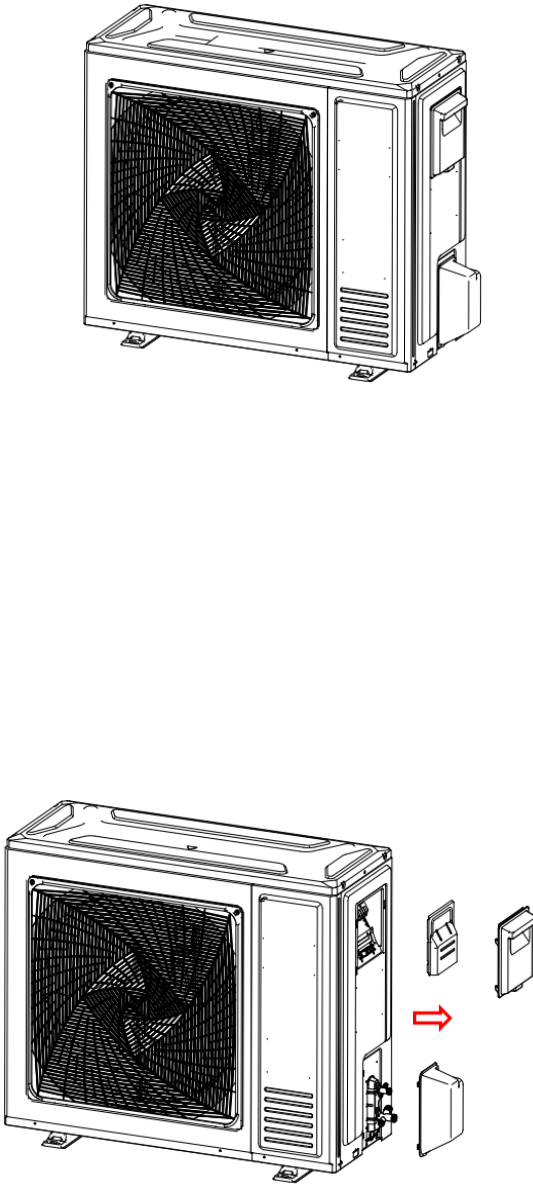
Step	1. Removal of Outdoor panel	Procedure	Points
1. Remove the panels			
1	Loosen the screws and lift the top panel and remove the handle.		

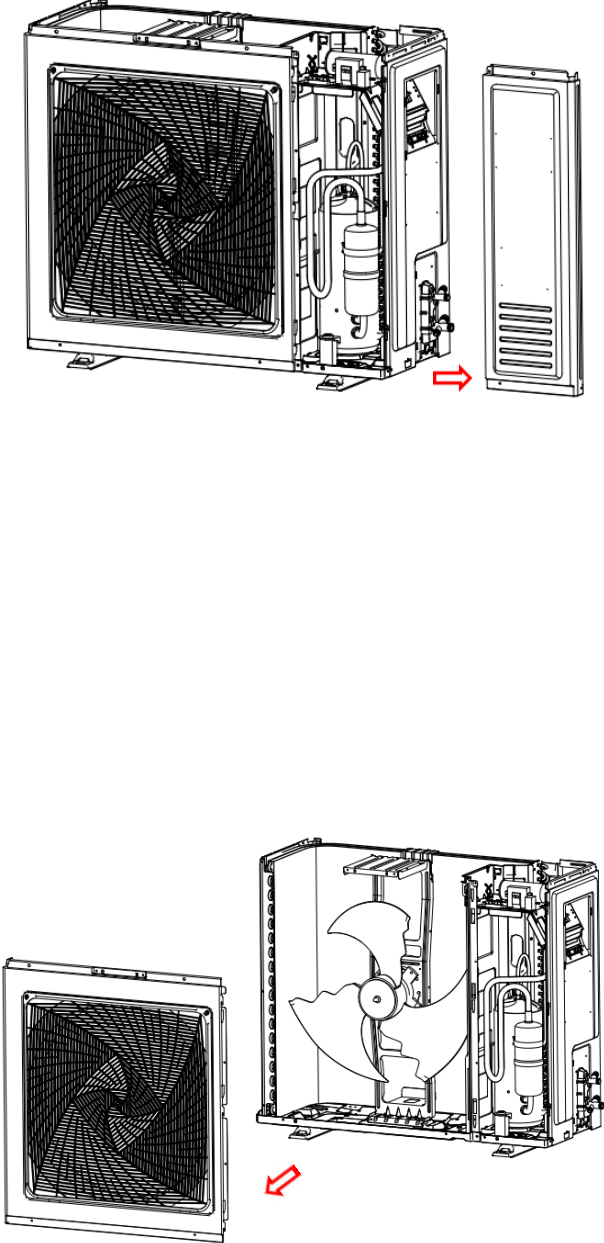
Step		Procedure	Points
2	Loosen the screws of the panel, pull and remove the front panel.	 <p>The top diagram shows a side view of the air conditioner with the front panel being pulled away from the main unit. A red arrow points to the right, indicating the direction of removal. The bottom diagram shows the front panel being pushed away from the main unit. A red arrow points to the left, indicating the direction of removal.</p>	

2. Removal of Electrical Box

Procedure



Warning Be sure to wait 10 minutes or more after turning off all power supplies before disassembling work

Step		Procedure	Points
1	Remove the fixing screws, Than lift the electrical box.		

3. Removal of Fan and Fan Motor

Procedure



Warning Be sure to wait 10 minutes or more after turning off all power supplies before disassembling work

Step		Procedure	Points
1	Loosen the fixing screw and remove the fan.		Put the head wire through the back of the motor when assembling.(so as not to be entangled with the propeller fan)

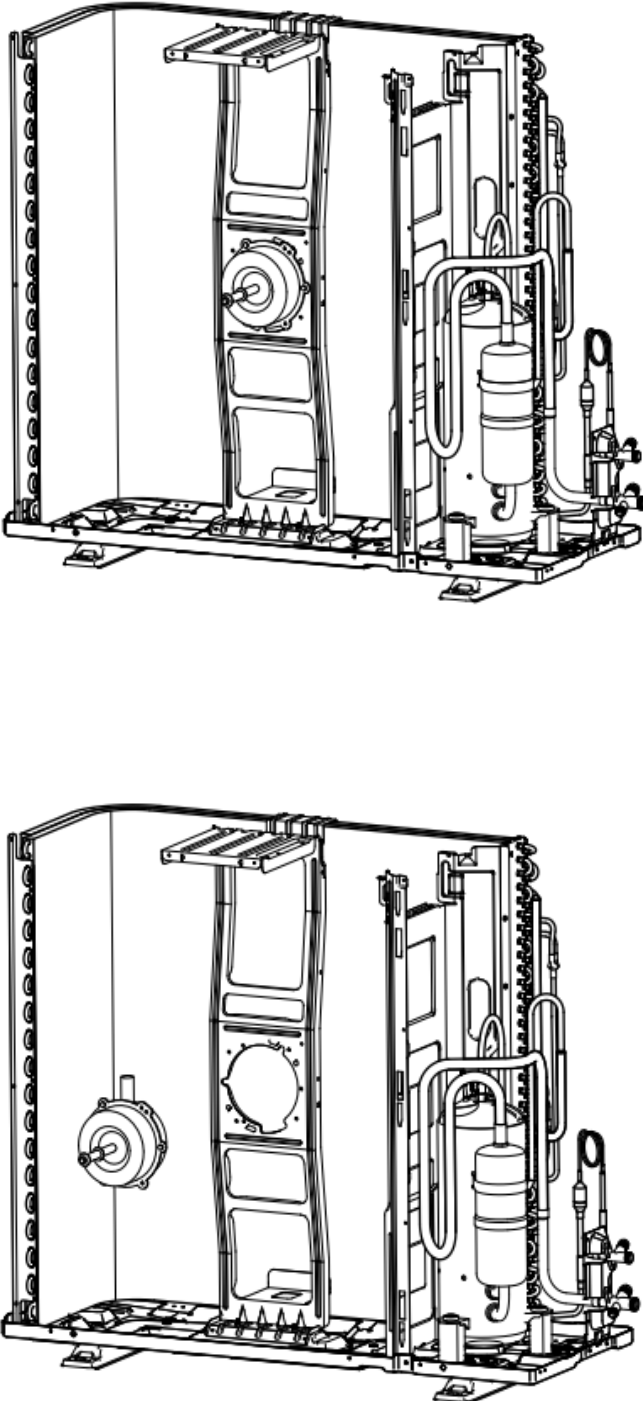
Step		Procedure	Points
2	<p>Loosen the fixing screws and remove the fan motor.</p>		

4. Removal of fan motor bracket and partition

Procedure



Warning Be sure to wait 10 minutes or more after turning off all power supplies before disassembling work

Step		Procedure	Points
1	Loosen the fixing screws and remove the fan motor bracket.		

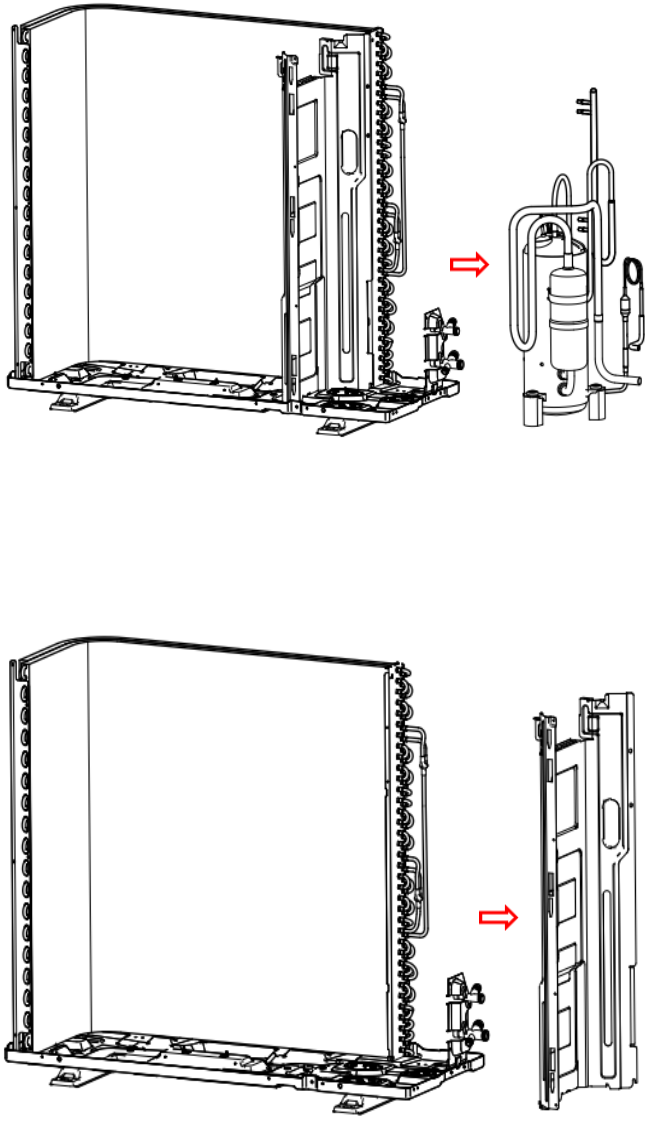
Step		Procedure	Points
2	<p>Loosen the fixing screws. The partition plate has a hook on the lower side, than lift and pull the proof plate. Remove the partition plate.</p>	 <p>The top diagram shows a side view of the air conditioner's main unit with the partition plate being lifted out. A red arrow points to the right, where the partition plate is shown fully removed, revealing the internal components like the compressor and coils. The bottom diagram shows a similar side view, but the partition plate is being pulled away from the bottom frame. A red arrow points to the right, where the partition plate is shown detached from the frame.</p>	<p>When assembling, fit the lower hook into the bottom frame.</p>

5 Removal of compressor and heat exchanger

Procedure



Warning Be sure to wait 10 minutes or more after turning off all power supplies before disassembling work

Step		Procedure	Points
1	<p>Cut down the connecting pipe and put out the compressor and remove the valve bracket.</p>		

Step		Procedure	Points
2	<p>Loosen the marked fixing screws and remove the heat exchanger.</p>	<p>The diagram illustrates the removal of the heat exchanger in three stages. In the first stage, the heat exchanger is shown being lifted away from the base unit. The second stage shows the base unit with a red arrow pointing upwards to the location where the heat exchanger was attached. The third stage shows the base unit with a red arrow pointing to a set of screws being removed from the unit.</p>	



Models

1U71XAGFRA
1U85XAGFRA

AS71PEGHRA
AS85PFGHRA

Please read this manual carefully before installation. This appliance is filled with R32.
Keep this operation manual for future reference.

00105113630



Contents

Warning	1
Loading and Unloading/Transporting Management/Storage Requirements.....	2
Installation Instructions.....	3
Relocation Procedures.....	8
Maintenance Instructions.....	9
Scrapping and Recovery.....	13
Indoor/Outdoor Unit Installion Drawings.....	12
Safety Precautions	14
Read Before Installation	17
Installation Procedure.....	20
Outdoor Unit Troubleshooting.....	25



Read the precautions in this manual carefully before operating the unit.



This appliance is filled with R32.

Keep this manual where the user can easily find it.

WARNING:

- ▲ Seek assistance from your dealer or qualified personnel for the installation of your air conditioner. Attempting to install it yourself could lead to risks such as water leakage, electric shocks, fire, or explosion.
- ▲ Install the air conditioner according to the instructions provided in the installation manual. Use only the specified accessories and parts for installation.
- ▲ Ensure the foundation can support the weight of the unit.
- ▲ Electrical work should comply with relevant local and national regulations and the instructions in the installation manual. Use a dedicated power supply circuit and appropriate wiring. The connecting wire type is H07RN-F.
- ▲ Use certified cables of suitable length and avoid using tapped wires or extension leads.
- ▲ Ensure all cables have local authentication certificates, and break off the grounding wire last during installation.
- ▲ Ventilate the area immediately if refrigerant gas leaks during installation.
- ▲ Check for refrigerant gas leakage after installation.
- ▲ Evacuate the refrigerant circuit during installation or relocation to remove air, and use only the specified refrigerant (R32).
- ▲ Ensure correct and reliable grounding. Do not earth the unit to utility pipes, lightning conductors, or telephone earth leads.
- ▲ Install an earth leakage circuit explosion-proof breaker and ensure proper disconnection means in the wiring.
- ▲ Do not use unauthorized means to accelerate defrosting or cleaning.
- ▲ Store the appliance in a room without continuously operating ignition sources, and ensure a radius of at least 2.5m around the storage area.
- ▲ Avoid piercing or burning the appliance, and be aware that refrigerants may not have an odor.
- ▲ Ensure the appliance is installed, operated, and stored in a well-ventilated room with a floor area larger than 3m.
- ▲ Comply with national gas regulations.
- ▲ This appliance is not intended for use by persons (including children) with reduced physical, sensory, or mental capabilities, unless supervised or instructed by a responsible person.
- ▲ Children should be supervised to prevent them from playing with the appliance, and cleaning and user maintenance should not be performed by children.
- ▲ Do not discard the air conditioner randomly; contact customer service if necessary.
- ▲ Connectors cannot be reused in a confined space.

CAUTION:

- ▲ Avoid installing the air conditioner in areas prone to flammable gas leakage to prevent fire hazards.
 - ▲ Ensure proper tightening of the flare nut using specified methods like a torque wrench to prevent cracking and refrigerant leakage.
 - ▲ Take measures to prevent small animals from seeking shelter in the outdoor unit to avoid electrical malfunctions or fire risks.
 - ▲ Encourage customers to maintain cleanliness around the unit to prevent debris accumulation and potential issues.
 - ▲ Keep the inter-unit wire away from uninsulated copper pipes due to high temperatures in the refrigerant circuit.
 - ▲ Only allow qualified personnel to handle tasks such as filling, purging, and disposing of refrigerant to ensure safety and compliance.
-

Loading and Unloading/Transporting Management/Storage Requirements

- **Loading and Unloading Requirements**

- 1) Handle products with care during loading and unloading to avoid damage.
- 2) Avoid impacting indoor and outdoor units to prevent product damage.
- 3) Read safety cautions before starting any work.
- 4) Equip the loading area with dry powder extinguishers or other suitable fire extinguishing apparatus.
- 5) Only trained personnel should be involved in loading and unloading air conditioners with flammable refrigerants.
- 6) Prohibit smoking and open fires around the air conditioner to prevent fire hazards.

- **Transporting Management Requirements**

- 1) The maximum transporting volume of finished products shall be determined as per local regulations.
- 2) The vehicles used for transporting shall be operated as per local laws and regulations.
- 3) Dedicated after-sales vehicles shall be used for maintenance transportation, and exposed transporting of refrigerant cylinders and the products to be maintained is not allowed.
- 4) A rain cover or similar shield material of the transporting vehicles should have certain flame retardancy.
- 5) Leakage warning device of flammable refrigerant shall be installed inside the closed-type compartment.
- 6) Anti-static device shall be equipped inside the compartment of transporting vehicles.
- 7) Dry powder extinguishers or other suitable fire extinguishing apparatus shall be equipped inside the driver's cab.
- 8) The transporting vehicles shall run at a constant speed, and heavy acceleration/deceleration shall be avoided. High-temperature area shall be avoided during transporting, and necessary radiating measures shall be taken in case the temperature inside the compartment is too high

- **Storage Requirements**

- 1) Ensure that the storage package of equipment prevents refrigerant leakage due to mechanical damage.
- 2) Determine the maximum quantity of equipment allowed to be stored together according to local regulations.

Installation Instructions

• Installation Precautions

WARNING!

- ★ Ensure that the room area where the R32 refrigerant air conditioner is installed meets the Transporting Management Requirements minimum requirement specified in the table below to prevent safety issues arising from refrigerant leakage.
- ★ Once the horn mouth of connecting lines is fastened, it should not be reused to maintain air tightness.
- ★ Use a whole connector wire for the indoor/outdoor unit as specified in the operation specification and operation instructions.
- ★ Manual should specify use of entire connection pipe.
- ★ Recommend placing joint of connection pipes at outdoor side; if not possible, non-reusable side must be installed indoors.
- ★ When reusing connection pipe, reinstall horn mouth

R32 Air Conditioner Adding Extra Gas With Longer Pipe Calculator

Diameter of the liquid connecting pipe (mm)	Extra gas amount per meter after standard length (g)
ø6/ø6.35	27.5g
ø9/ø9.52	50g

Notes:
 1、 The most gas amount should be: initial gas amount + extra gas amount < permitted gas by safety standard.
 2、 The extra gas amount per meter shall not exceed 30g.

Minimum Room Area

Type	LFL kg/m ³	hv m	Total Mass Charged/kg Minimum Room Area/m ²						
			4	7	10	15	20	30	50
R32	0.306	0.6	0.68	0.90	1.08	1.32	1.53	1.87	2.41
		1.0	1.14	1.51	1.80	2.20	2.54	3.12	4.02
		1.8	2.05	2.71	3.24	3.97	4.58	5.61	7.24
		2.2	2.50	3.31	3.96	4.85	5.60	6.86	8.85

• Important Information Regarding The Refrigerant Used

Product contains fluorinated greenhouse gases under Kyoto Protocol. Do not vent into the atmosphere. Refrigerant type: R32

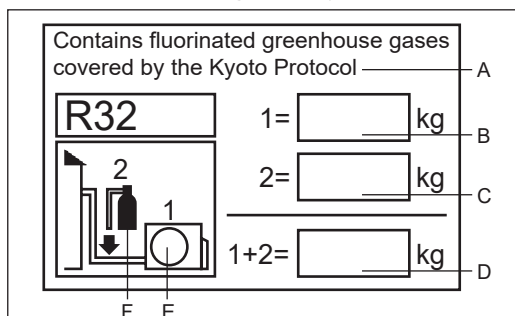

- A contains fluorinated greenhouse gases covered by the Kyoto Protocol
 - B factory refrigerant charge of the product: see unit name plate
 - C additional refrigerant amount charged in the field
 - D total refrigerant charge
 - E outdoor unit
 - F refrigerant cylinder and manifold for charging
- GWP=global warming potential

- 1 the factory refrigerant charge of the product
- 2 the additional refrigerant amount charged in the field
- 1+2 the total refrigerant charge
- 3 GWP* value=675
tCO₂=(1+2) x 3 /1000

Installation Instructions

Model	Factory charge (kg)	CO2 Equivalent(t)
1U71XAGFRA	1.65	1.11
1U85XAGFRA	1.70	1.15

The maximum refrigerant charge amount (M)

Indoor unit	Outdoor unit	M kg
AS71PEGHRA	1U71XAGFRA	2.75
AS85PFGHRA	1U85XAGFRA	2.80

- **Safety Awareness**

1. Procedures: Follow controlled procedures to reduce risks.
2. Area: Divide and isolate areas appropriately, avoid enclosed spaces. Ensure ventilation before starting refrigeration system or hot working.
3. Site inspection: Check refrigerant.
4. Fire control: Place fire extinguisher nearby, prohibit fire sources or high temperatures. Display "No smoking" signs.

- **Unpacking Inspection**

1. Indoor unit:
 - Check the red sign at the top of the green plastic seal cap on the evaporator air pipes after unpacking.
 - If the red sign is raised, nitrogen sealing is intact.
 - Press the black plastic seal cap at the joint of evaporator liquid pipes to check for nitrogen presence.
 - If no nitrogen is sprayed out, the indoor unit may have leakage, and installation is not allowed.
2. Outdoor unit:
 - Extend leak detection equipment into the packing box of the outdoor unit.
 - Check for refrigerant leakage.
 - If refrigerant leakage is detected, installation is not allowed, and the unit must be delivered to the maintenance department.

- **Inspection on Installation Environment**

1. Ensure the room area meets or exceeds the minimum area specified on the warning sign of the indoor unit.
2. For outdoor units of air conditioners using flammable refrigerants, avoid installing them inside enclosed rooms.
3. Avoid placing power supply outlets, switches, or other high-temperature objects such as fire sources or oil heaters beneath the indoor unit.
4. Ensure proper grounding of the power supply by providing an earthing wire and reliable earthing connection.
5. Before drilling holes in the wall, verify if there are any embedded water, electricity, or gas pipelines in the designated area. It is recommended to use existing through-wall holes whenever possible.
6. Damaged products must be taken to the maintenance point for repair. Welding of refrigerant pipelines on-site is not permitted.
7. Ensure the air conditioner's installation position allows for easy maintenance. Avoid placing obstacles near the indoor and outdoor unit air inlets/outlets and keep electrical appliances, power switches, sockets, valuables, and high-temperature items away from the indoor unit's sidelines.

Installation Instructions

• Safety Principles of Installation

1. Favorable ventilation shall be maintained at the place of installation (doors and windows are opened).
2. Open fire or high-temperature heat source (including welding, smoking and oven) higher than 548 °C is not allowed within the scope of flammable refrigerant.
3. Anti-static measures shall be taken, such as the wearing of cotton clothes and cotton gloves.
4. The place of installation shall be convenient for installation or maintenance, and cannot be adjacent to heat source and flammable and combustible environment.
5. In case of refrigerant leakage of the indoor unit during installation, the valve of the outdoor unit shall be closed immediately, and windows shall be opened, and all the personnel shall be evacuated. After the leakage of refrigerant is handled, the indoor environment shall be subject to concentration detection. Further handling is not allowed until the safety level is reached.
6. In case the product is damaged, it must be delivered to the maintenance point. Welding of refrigerant pipelines at the user's site is not allowed.
7. The installation position of air conditioner shall be convenient for installation or maintenance. Barriers shall be avoided around the air inlet/outlet of the indoor/outdoor unit, and the electrical appliance, power switches, sockets, valuables and high-temperature products within the scope of both sidelines of the indoor unit shall be avoided.



No fire source around
the place of installation



Cotton clothes



Anti-static gloves



BEWARE
ELECTROSTATICS



Goggles



Read operator' manual



Read technical manual



Operator' manual; operating instructions

• Electrical Safety Requirements

Note:

1. Pay attention to surrounding conditions such as ambient temperature, direct sunlight, and rainwater during electrical wiring, and implement effective protective measures.
2. Use copper wire cables that comply with local standards for both the power line and connector wire.
3. Ensure both the indoor unit and outdoor unit are reliably earthed.
4. Complete wiring for the outdoor unit before proceeding with the indoor unit. Power on the air conditioner only after completing wiring and pipe connections.
5. Use a dedicated branch circuit and install a leakage protector with sufficient capacity.

• Qualification Requirements of Installer

Relevant qualification certificate must be obtained as per national laws and regulations.

• Indoor Unit Installation

1. Fixation of wall panel and piping layout

If the left/right water pipe connection for the indoor unit is necessary, or if the evaporator interface of the indoor unit and the horn mouth of the connecting piping cannot be extended to the outdoor side for installation, the connector pipes shall be connected to the evaporator piping interface of the indoor unit during the horn mouth process.

2. Piping layout

During the layout of connecting pipes, drain hose, and connector wires, adhere to the following guidelines:

- Place the drain hose at the bottom and the connector wire at the top.
- Avoid intertwining the power line with the connector wire.
- Ensure proper ventilation and thermal insulation for drain pipes, especially those inside the room and machine.

Installation Instructions

3. Nitrogen charging for pressure maintaining and leak detection

After connecting the evaporator of the indoor unit to the connector pipe and welding, follow these steps for pressure testing and leak detection:

1. Charge nitrogen at a pressure above 4.0MPa into the evaporator and the connected piping using a nitrogen cylinder equipped with a reducing valve. Close the valve of the nitrogen cylinder and perform leak detection using soapy water or a leak detecting solution. Maintain the pressure for at least 5 minutes and observe if the system pressure decreases, indicating a leak. If a leak is detected, address the leak point and repeat the process.

2. After connecting the evaporator of the indoor unit to the connecting piping, charge nitrogen for pressure maintenance and leak detection. Then connect the evaporator to the two-way stop valve and three-way stop valve of the outdoor unit. After fastening the copper cap of the connecting piping, charge nitrogen above 4.0MPa at the access hole of the three-way stop valve using a charging hose. Perform leak detection as described above.

3. Alternatively, perform the above steps after connecting the indoor unit to the connecting pipelines and the two-way stop valve and three-way stop valve of the outdoor unit. Connect the access hole of the outdoor unit to the nitrogen cylinder and pressure gauge and charge nitrogen above 4.0MPa. Ensure each joint is accessible for leak detection.

After completing the installation steps and ensuring no leaks, proceed with evacuating using a vacuum pump.

• Outdoor Unit Installation

1. Fixation and connection

Note:

- a) Avoid any fire sources within a 3-meter radius around the installation site.
- b) Place the refrigerant leak detection equipment at a low position outdoors and ensure it is open.

1) Mounting

Attach the outdoor unit securely to the wall surface, ensuring horizontal alignment. For wall or roof installations, firmly secure the support to prevent damage from strong winds.

2) Connecting Pipe Installation

Align the cone of the connecting pipes with the conical surface of the valve connector. Install the nut of the connecting pipes in the correct position and tighten it using a spanner. Avoid excessive torque to prevent damage to the nut.



• Evacuating

Utilize a digital vacuum gauge during the evacuation process. Maintain the vacuum for a minimum of 15 minutes, ensuring the pressure on the gauge remains below 60Pa. Once completed, close the vacuum equipment and observe the digital gauge reading for any increase in pressure over 5 minutes. If no leaks are detected, proceed to open the two-way and three-way stop valves on the outdoor unit. Finally, disconnect the vacuum hose from the outdoor unit.

• Leak Testing

Check the joints of the connecting pipes for the outdoor unit using either soap bubbles or specialized leak detection equipment.

- **Post-installation Inspection Items and Test Run**

Post-installation Inspection Items

Items to Be Checked	Consequence of Improper Installation
Whether the installation is firm or not	The unit may fall, vibrate or make a noise
Whether the inspection on air leakage is completed	The refrigerating capacity (heating capacity) may be insufficient
Whether the unit is fully insulated	Condensation or drip may occur
Whether the drainage is smooth or not	Condensation or drip may occur
Whether the power voltage is identical to that marked on the nameplate	Failure may occur or the parts may be burned
Whether the circuit and pipeline are installed correctly	Failure may occur or the parts may be burned
Whether the unit is safely earthed	Electric leakage may occur
Whether the type of wire is in line with relevant regulations	Failure may occur or the parts may be burned
Whether barriers are identified at the air inlet/outlet of the indoor/outdoor unit	The refrigerating capacity (heating capacity) may be insufficient
Whether the length of refrigerant pipes and the refrigerant amount charged are recorded	The refrigerant amount charged cannot be confirmed

Test Run

1. Preparations
 - 1) Power must not be turned on until all installation tasks are finished and leak detection is confirmed.
 - 2) Ensure correct connection of the control circuit with all wires securely fastened.
 - 3) Open the two-way and three-way stop valves.
 - 4) Clean the unit thoroughly, removing any scattered items, particularly metal filings and thread residues.
2. Methods
 - 1) Activate the power supply and use the remote controller to press "ON/OFF" to start the air conditioner.
 - 2) Press "Mode" to choose between refrigeration, heating, and fan modes, then observe the air conditioner for normal operation.

1. DRED Installation Instruction

Please consult your reseller and/or installer to determine if you have a DRED appliance.

1 Open cover piece and locate board.

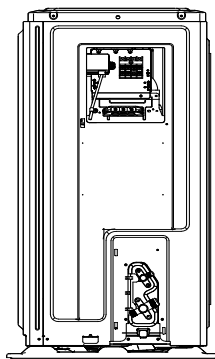

1U71XAGFRA
1U85XAGFRA

- 2 The installation position of the DRED (Demand Response Enabling Device) module should be selected based on the specific outdoor unit and the type of electrical box coupling being used.

Relocation Procedures

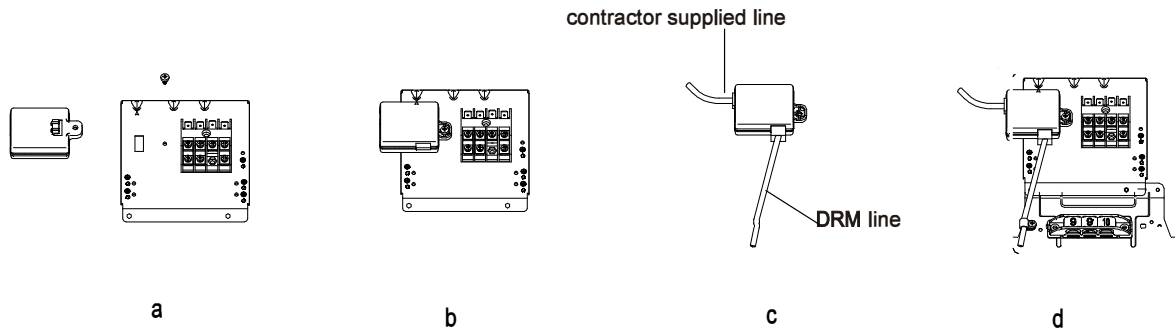

- a. Attach the DRED module to the board using the bayonet mechanism.
 - b. Use screws to secure the DRED module firmly.
 - c. Connect the contractor-supplied line to the DRM line.
 - d. Use a clamp to secure the DRM line and fasten it with a screw.
 - e. Connect the contractor-supplied line to the PCB via interface CN49.
- 3 Refit the stop valve cover.

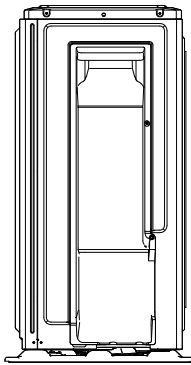

Relocation Procedures

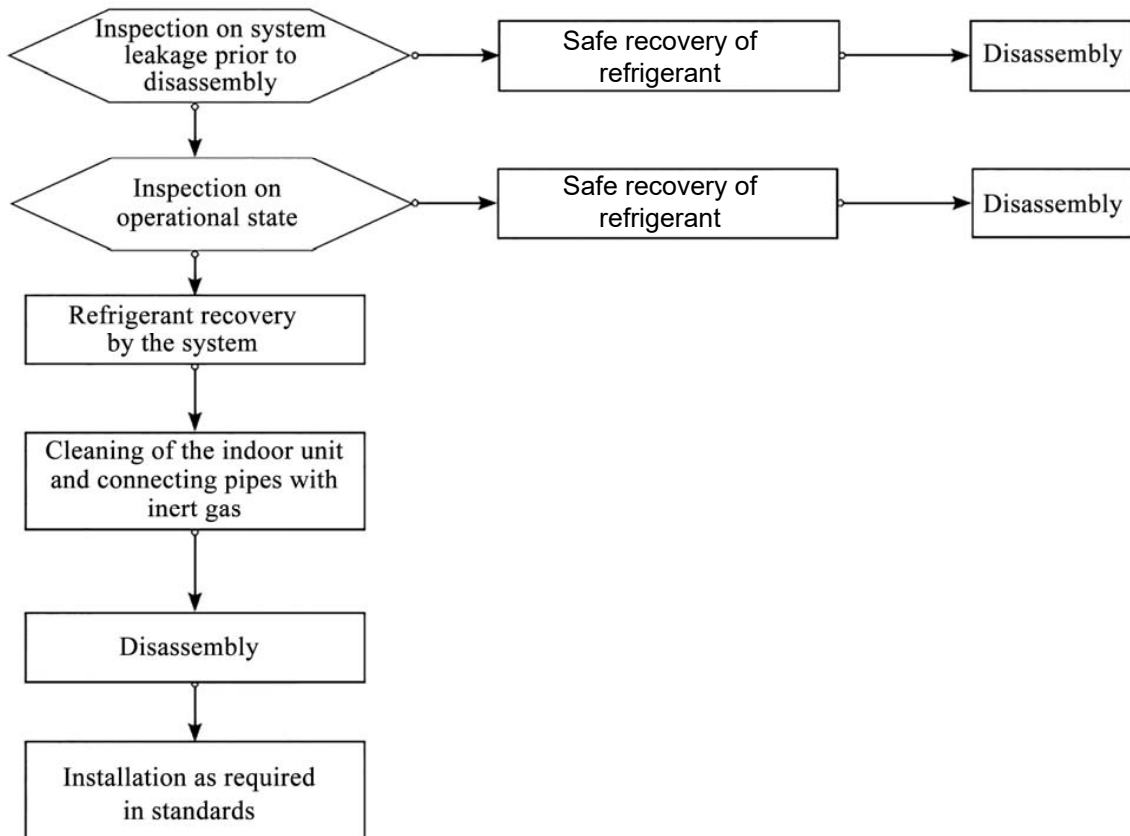

Note: If relocation is necessary, cut off the joint of the evaporator gas/liquid pipes of the indoor unit using a cutting knife. Reconnection is permitted only after re-flaring, following the same procedure for the outdoor unit.

Maintenance Instructions

Maintenance Precautions

Precautions

- Maintenance involving welding of refrigeration pipelines or components within the R32 refrigerant air conditioner system should never be conducted at the user's site.
- Tasks necessitating extensive disassembly and bending operations on the heat exchanger, such as replacing the outdoor unit chassis or fully disassembling the condenser, are strictly prohibited from being performed at the user's site.
- Replacement of the compressor or refrigeration system components is not permitted to be carried out at the user's site.
- Other faults not affecting the refrigerant container, internal refrigeration pipelines, or refrigeration elements may be addressed at the user's site, including cleaning and clearing the refrigeration system without disassembling refrigeration elements or welding.
- If replacement of gas/liquid pipes is needed during maintenance, the joint of the indoor unit's evaporator gas/liquid pipes must be cut with a cutting knife. Reconnection is only permissible after re-flaring, following the same procedure as for the outdoor unit.

Qualification Requirements of Maintenance Personnel

- Every operator or maintenance personnel involved in refrigerating circuits must possess a valid certificate issued by an industry-recognized assessment institute, ensuring their qualification for safely handling refrigerants in compliance with assessment regulations.
- Maintenance and repairs of the equipment should strictly adhere to the manufacturer's recommended methods. If assistance from personnel from other disciplines is needed, it must be supervised by personnel holding certification in handling flammable refrigerants.

Inspection on Maintenance Environment

- Prior to operation, any leaked refrigerant in the room must be cleared.
- The maintenance area's dimensions should align with those specified on the equipment's nameplate.
- Adequate ventilation must be maintained throughout the maintenance process.
- Open flames or heat sources exceeding 548 degrees, capable of igniting easily, are strictly prohibited within the maintenance area.
- All operators in the maintenance area must power off their phones and any electronic devices emitting radiation during maintenance.
- A functioning dry powder or carbon dioxide extinguisher must be readily available inside the maintenance area.

Maintenance Site Requirements

- The maintenance site must have adequate ventilation and be level. Setting up the maintenance site in a basement is not permitted.
- Clearly demarcate welding and non-welding zones at the maintenance site, ensuring a safe distance between them.
- Install ventilators, exhaust fans, ceiling fans, floor fans, and dedicated exhaust ducts to meet ventilation and exhaust requirements, preventing the accumulation of refrigerant gas.
- Equip flammable refrigerant leak detection devices and establish a management system for their maintenance. Confirm the availability of leak detection equipment before commencing maintenance.
- Provide sufficient dedicated vacuum pumps and refrigerant charging equipment for flammable refrigerants, with a management system ensuring each equipment is used exclusively for one type of refrigerant.
- Install the main power switch outside the maintenance site, equipped with protective (anti-explosive) devices.
- Store nitrogen, acetylene, and oxygen cylinders separately, with a minimum distance of 6m between gas cylinders and areas involving open flames. Acetylene cylinders should be equipped with anti-backfire valves, and their colors must meet international standards.
- Display "No Fire" warning signs within the maintenance area.
- Equip fire control devices suitable for electrical appliances such as dry powder or carbon dioxide extinguishers, ensuring they are always available for use.

Maintenance Instructions

- The ventilator and other electrical equipment at the maintenance site must be securely fixed with standardized pipe routing. Temporary wires and sockets are strictly prohibited at the maintenance site.

Leak Detection Methods

- The area where refrigerant leakage is checked must be free from potential ignition sources. Avoid using halogen probes or detectors with open flames for leak detection.
- For systems containing flammable refrigerants, electronic leak detection equipment may be used. During calibration and use, ensure the environment is free from refrigerant and that the equipment does not pose an ignition risk. It should also be suitable for the refrigerant being detected. The equipment should be set to a percentage of the Lower Flammable Limit (LFL) of the refrigerant and calibrated accordingly, with gas concentrations kept within safe limits (up to 25% maximum).
- The fluid used for leak detection should be compatible with most refrigerants. Avoid using chlorine-containing solvents to prevent chemical reactions with refrigerants and corrosion of copper pipelines.
- If a leak is suspected, evacuate or extinguish any open flames in the vicinity.
- If welding is necessary at the leak site, either recover all refrigerants or isolate them far from the leak point using a stop valve. Before and during welding, the entire system should be purged with Oxygen-Free Nitrogen (OFN).

Maintenance Items

Maintenance Requirements

- Before operating the refrigeration system, clean the circulating system with nitrogen. Next, evacuate the outdoor unit for a duration of no less than 30 minutes. Finally, utilize 1.5~2.0MPa OFN for nitrogen flushing (lasting 30 seconds to 1 minute) to pinpoint areas requiring treatment. Maintenance of the refrigeration system is permissible only after removing any residual gas of flammable refrigerant.
- When using refrigerant charging tools, prevent cross-contamination of different refrigerants, and minimize the total length (including refrigerant pipelines) to reduce residual refrigerant.
- Ensure refrigerant cylinders are kept upright and securely fixed.
- Ground the refrigeration system before charging refrigerant.
- Charge the specified type and volume of refrigerant as indicated on the nameplate; excessive charging is prohibited.
- Seal the refrigeration system securely after maintenance.
- Ensure that ongoing maintenance does not compromise or reduce the original safety protection level of the system.

Maintenance of Electrical Components

- During maintenance, inspect a portion of the electrical components for refrigerant leakage using dedicated leak detection equipment.
- Post-maintenance, refrain from disassembling or removing components with safety protection functions.
- When conducting maintenance on sealing elements, power off the air conditioner before opening the seal cover. If power supply is necessary, conduct continuous leak detection at the most critical position to mitigate potential risks.
- Replacement of enclosures during maintenance of electrical components should not compromise the level of protection.
- After maintenance, ensure that sealing functions remain intact and sealing materials do not lose their ability to prevent the entry of flammable gas due to aging. Substituted components should meet the manufacturer's recommended requirements for the air conditioner.

Maintenance of Intrinsically Safe Elements

The intrinsically safe element refers to the components working continuously inside flammable gas without any risks.

Maintenance Instructions

- Prior to any maintenance, perform leak detection and inspect the grounding reliability of the air conditioner to ensure no leaks and reliable grounding.
- If the service of the air conditioner may exceed the allowable voltage and current limits, do not add any inductance or capacitance to the circuit.
- Use only parts and components designated by the air conditioner manufacturer for replacement, as using unauthorized parts may pose a fire hazard in the event of refrigerant leakage.
- If maintenance work does not involve system pipelines, ensure that the pipelines are well protected to prevent any leaks during maintenance.
- After maintenance and before conducting a test run, perform leak detection and inspect the grounding reliability of the air conditioner using leak detection equipment or a leak-detecting solution. Ensure that the startup inspection is conducted without any leaks and with reliable grounding.

Removal and Evacuation

Maintenance or other operations on the refrigeration circuit should adhere to conventional procedures, with a primary consideration on the flammability of the refrigerant. The following steps should be followed:

1. Refrigerant clearing
2. Pipeline purification with inert gas
3. Evacuation
4. Pipeline purification again with inert gas
5. Pipeline cutting or welding, with the refrigerant recovered into a suitable cylinder. The system should then be purged with Oxygen-Free Nitrogen (OFN) for safety. This step may need to be repeated several times, and compressed air or oxygen should not be used for purging.

During purging, OFN should be charged into the refrigeration system while under a vacuum to reach operating pressure. Subsequently, the OFN should be discharged into the atmosphere. Finally, evacuation of the system should be performed. This process should be repeated until all refrigerants in the system are cleared. The OFN charged for the last time should also be discharged into the atmosphere before welding can occur. This procedure is essential for pipeline welding.

Ensure that no open flame sources are near the outlet of the vacuum pump, and that ventilation is adequate.

Welding

- Adequate ventilation in the maintenance area must be ensured. After the maintenance machine undergoes the evacuation process, the system refrigerant can be discharged on the outdoor unit side.
- Before welding the outdoor unit, ensure that no refrigerant remains inside and that the system refrigerant has been discharged and cleared.
- Under no circumstances should refrigeration pipelines be cut with a welding gun. Instead, disassemble the refrigeration pipelines using a pipe cutter, ensuring that the disassembly is conducted around a ventilation opening.

Refrigerant Charging Procedures

Additional requirements to conventional procedures:

- Ensure refrigerant charging tools are used without cross-contamination of different refrigerants. Minimize the total length of the system (including refrigerant pipelines) to reduce residual refrigerant.
- Store refrigerant cylinders upright.
- Ground the refrigeration system before charging refrigerant.
- Apply a label to the refrigeration system after refrigerant charging.
- Avoid excessive charging; charge refrigerant slowly.
- If system leakage is detected, refrain from charging refrigerant until the leak point is sealed.
- During refrigerant charging, measure the amount using an electronic or spring scale. Ensure the connecting hose between the refrigerant cylinder and charging equipment is appropriately relaxed to maintain measurement accuracy and avoid stress.

Storage site requirements for refrigerant:

- Store refrigerant cylinders in an environment with temperatures ranging from -10°C to 50°C, with adequate ventilation. Apply warning labels.
- Store and use maintenance tools in contact with refrigerant separately, ensuring tools for different refrigerants are not mixed.

Scrapping and Recovery

Scrapping

Before scrapping, the technician shall be completely familiar with the equipment and all its features. All scheduled refrigerant being removed from equipment must be recovered and either recycled, reclaimed or disposed of, in accordance with the relevant international/Australian/New Zealand Standards. In case the refrigerant recovered needs to be reused, before which the sample of refrigerant and oil shall be analyzed. The power supply required shall be guaranteed before tests.

- (1) The equipment and operation shall be well known;
- (2) Power supply shall be switched off;
- (3) The followings shall be guaranteed before scrapping:
 - The mechanical equipment shall be convenient for operation on the cylinder of refrigerant (if necessary);
 - All personal protective equipment is available and being used correctly;
 - The whole course of recovery shall be guided by qualified personnel;
 - The recovery equipment and cylinders shall be in line with corresponding standards.
- (4) The refrigeration system shall be evacuated if possible;
- (5) If the vacuum state cannot be reached, evacuation should be conducted from multiple positions to remove refrigerant from each part of the system.
- (6) Ensure that cylinder capacities are sufficient before recovery.
- (7) Operate the recovery equipment according to the manufacturer's instructions.
- (8) Do not overfill the cylinder. The refrigerant charged should not exceed 80% of the cylinder's capacity.
- (9) Do not exceed the maximum operating pressure of cylinders, even for short periods.
- (10) After refrigerant charging is completed, rapidly evacuate the cylinder and equipment, and close all stop valves on the equipment.
- (11) Refrigerant recovered must not be charged into another refrigeration system before purification and testing.

Note:

After scrapping the air conditioner and recovering the refrigerant, mark the air conditioner (with dates and signature). Ensure that the marking on the air conditioner reflects the flammable refrigerant charged inside.

Recovery

During maintenance or scrapping, it's essential to thoroughly clear the refrigerant from the refrigeration system.

- 1) Refrigerant should only be charged into dedicated cylinders with capacities matching the refrigerant amount in the system. These cylinders should be labeled accordingly and equipped with pressure relief valves and stop valves. Empty cylinders should be evacuated before use and stored at normal temperature if possible.
- 2) The recovery equipment should always be in good working condition and equipped with operation instructions for easy reference. It should be suitable for recovering flammable refrigerants and equipped with weighing apparatus with valid measurement certificates. Removable attachment joints for hoses, free from leaks, should always be maintained. Check the condition of the recovery equipment and all electrical components before use to prevent fire in case of refrigerant leakage. Contact your local dealer or qualified personnel if you have any questions.
- 3) Recovered refrigerant should be returned to the manufacturer in appropriate cylinders with attached transportation instructions. Mixing refrigerants in recovery equipment, especially cylinders, is prohibited.
- 4) During transportation, the space where flammable refrigerant air conditioners are loaded must not be sealed. If necessary, anti-static measures should be taken for transporting vehicles. Additionally, necessary protective measures should be taken during loading and unloading to prevent damage to the air conditioners.
- 5) When removing the compressor or clearing compressor oil, ensure the compressor is evacuated to remove any residual flammable refrigerant from the lubricating oil. Evacuation should be completed before returning the compressor to the manufacturer. Evacuation can only be accelerated by heating the compressor housing through electrical heating. Safety measures should be observed when discharging oil from the system.

Safety Precautions

⚠ WARNING

- | | |
|---|---|
| <ul style="list-style-type: none"> • Have the unit professionally installed. Improper installation by an unqualified person may result in water leak, electric shock, or fire. • Place the unit on a stable, level surface capable of withstanding its weight to prevent tipping over or falling, which could cause injury. • Only use specified cables for wiring. • Securely connect each cable, ensuring they are not straining the terminals. • Improperly connected cables may generate heat and cause a fire. • Take necessary safety measures against typhoons and earthquakes to prevent the unit from falling over. • Do not make any changes or modifications to the unit. In case of problems, consult the dealer. If repairs are not made properly, the unit may leak water and present a risk of electric shock, or it may produce smoke or cause fire. | <ul style="list-style-type: none"> • Be sure to carefully follow each step in this handbook when installing the unit. Improper installation may result in water leak, electric shock, fire or explosion. • Have all electrical work performed by a licensed electrician according to the local regulations and the instructions given in this manual. Secure a circuit designated exclusively to the unit. Improper installation or a lack of circuit capacity may cause the unit to malfunction or present a risk of electric shock, fire or explosion. • Securely attach the terminal cover(panel) on the unit. If installed improperly, dust and/or water may enter the unit and present a risk of electric shock, smoke or fire. • Using any refrigerant other than the specified type or introducing air into the unit circuit may cause the unit to run abnormally and potentially burst. |
|---|---|

⚠ WARNING

- | | |
|--|--|
| <ul style="list-style-type: none"> • Do not touch the fins on the heat exchanger with bare hands, for they are sharp and dangerous. • In the event of a refrigerant gas leak, provide adequate ventilation to the room. If leaked refrigerant gas is exposed to a heat source, noxious gases, fire or explosion will be caused. • Do not try to defeat the safety features of the devices, and do not change the settings. Defeating the safety features on the unit such as the pressure switch and temperature switch or using parts other than the dealer or specialist may result in fire or explosion. | <ul style="list-style-type: none"> • When installing the unit in a small room, safeguard against hypoxia that results from leaked refrigerant reaching the threshold level. Consult the dealer for necessary measures to take. • When relocating the air conditioner, consult the dealer or a specialist. Improper installation may result in water leak, electric shock, fire or explosion. • After completing the service work, check for a refrigerant gas leak. If leaked gas refrigerant is exposed to a heat source such as fan heater, stove, and electric grill, noxious gases, fire or explosion. • Only use specified parts. Have the unit professionally installed. Improper installation may cause water leak, electric shock, smoke, fire, explosion. |
|--|--|

Precautions for Handling Units for Use with R32

⚠ Caution

- | | |
|---|---|
| <p>Do not use the existing refrigerant piping</p> <ul style="list-style-type: none"> • The old refrigerant and refrigerator oil in the existing piping contain a large amount of chlorine, which will cause the refrigerator oil in the new unit to deteriorate. • R32 is a high-pressure refrigerant, and the use of the existing piping may result in bursting. <p>Keep the inner and outer surfaces of the pipes clean and free of contaminants such as sulfur, oxides, dust/dirt shaving particles, oils, and moisture.</p> <ul style="list-style-type: none"> • Contaminants inside the refrigerant piping will cause the refrigerant oil to deteriorate. | <p>Use a vacuum pump with a reverse-flow check valve.</p> <ul style="list-style-type: none"> • If other types of valves are used, the vacuum pump oil will flow back into the refrigerant cycle and cause the refrigerator oil to deteriorate. <p>Do not use the following tools that have been used with the conventional refrigerants. Prepare tools that are for exclusive use with R32 .
(Gauge manifold, charging hose, gas leak detector, reverse-flow check valve, refrigerant charge base, vacuum gauge, and refrigerant recovery equipment.)</p> <ul style="list-style-type: none"> • If refrigerant and/or refrigerant oil left on these tools are mixed in with R32 , or if water is mixed with R32 , it will cause the refrigerant to deteriorate. • Since R32 does not contain chlorine, gas-leak detectors for conventional HFC refrigerants will not work |
|---|---|

Safety Precautions

⚠ Caution

Store the piping to be used during installation indoors, and keep both ends of the piping sealed until immediately before brazing.(keep elbows and other joints wrapped in plastic.)

- If dust, dirt, or water enters the refrigerant cycle, it may cause the oil in the unit to deteriorate or may cause the compressor to malfunction.

Use a small amount of ester oil, ether oil, or alkylbenzene to coat flares and flange connections.

- A large amount of mineral oil will cause the refrigerating machine oil to deteriorate.

Use liquid refrigerant to charge the system.

- Charge the unit with gas refrigerant will cause the refrigerant in the cylinder to change its composition and will lead to a drop in performance

Do not use a charging cylinder.

- The use of charging cylinder will change the composition of the refrigerant and lead to power loss.

Exercise special care when handling the tools.

- An introduction of foreign objects such as dust, dirt or water into the refrigerant cycle will cause the refrigerating machine oil to deteriorate.

Only use R32 refrigerant.

- The use of refrigerants containing chlorine(i.e. R22) will cause the refrigerant to deteriorate.

Before Installing the Unit

⚠ Caution

Do not install the unit in a place where there is a possibility of flammable gas leak.

- Leaked gas accumulated around the unit may start a fire.

Do not use the unit to preserve food, animals, plants, artifacts, or for other special purposes.

- The unit is not designed to provide adequate conditions to preserve the quality of these items.

Do not use the unit in an unusual environment

- The use of the unit in the presence of a large amount of oil, steam, acid, alkaline solvents or special types of sprays may lead to a remarkable drop in performance and/or malfunction and presents a risk of electric shock, smoke, or fire.
- The presence of organic solvents, corroded gas (such as ammonia, sulfur compounds, and acid may cause gas or water leak.)

When installing the unit in a hospital, take necessary measures against noise.

- High-frequency medical equipment may interfere with the normal operation of the air conditioning unit or the air conditioning unit may interfere with the normal operation of the medical equipment

Do not place the unit on or over things that may not get wet.

- When humidity level exceeds 80% or when the drainage system is clogged, indoor units may drip water.
- Installation of a centralized drainage system for the outdoor unit may also need to be considered to prevent water drips from the outdoor units.

Carefully read the following information in order to operate the air conditioner correctly.

Below are listed three kinds of Safety Precautions and Suggestions.

⚠ WARNING Incorrect operations may result in severe consequences of death or serious injuries.

⚠ CAUTION Incorrect operations may result in injuries or machine damages; in some cases may cause serious consequences.

INSTRUCTIONS: These information can ensure the correct operation of the machine.

Symbols used in the illustrations

⊘ :Indicates an action that must be avoided.

⦿ :Indicates that important instructions must be followed.

⚡ :Indicates a part which must be grounded.

⚡ :Beware of electric shock (This symbol is displayed on the main unit label.)

After reading this handbook, hand it over to those who will be using the unit.

The user of the unit should keep this manual at hand and make it available to those who will be performing repairs or relocating the unit. Also, make it available to the new user when the user changes hands.

Be sure to conform with the following important Safety Precautions.

⚠ WARNING

- If any abnormal phenomena is found (e. g.smell of firing), please isolate the power supply immediately, and contact the dealer to find out the handling method.

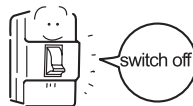

Open the window and well ventilated the room.

In such case, to continue using the conditioner will damage the conditioner, and may cause electrical shock or fire hazard.

- After a long time use of air-conditioner the base should be checked for any damages.



If the damaged base is not repaired, the unit may fall down and cause accidents.

- Don't dismantle the outlet of the outdoor unit. The exposure of fan is very dangerous which may harm human beings.



- When need maintenance and repairment, call dealer to handle it. Incorrect maintenance and repairment may cause water leak, electrical shock and fire hazard.



Safety Precautions

⚠ WARNING

- If any abnormal phenomena is found (e. g. smell of firing), please cut off the power supply immediately, and contact the dealer to find out the handling method.
Open the window and well ventilated the room.
In such a case, continuing to use the conditioner may damage it and pose risks of electrical shock or fire hazards.
- After prolonged use of the air conditioner, it's advisable to check the base for any damages.
If the damaged base is not repaired, the unit may fall down and cause accidents.
- No goods or nobody is permitted to placed on or stand on outdoor unit. The falling of goods and people may cause accidents.
- Don't operate the air-conditioner with damp hands. Otherwise it will be shocked.
- Only use explosion-proof fuse .
May not use wire or any other materials replacing fuse, otherwise it may cause faults or fire accidents.
- Use discharge pipe correctly to ensure efficient discharge.
Incorrect pipe use may cause water leaking.
- Installed electrical-leaking circuit breaker.
It easily cause electrical shock without circuit breaker.

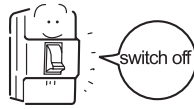

- Don't dismantle the outlet of the outdoor unit.
The exposure of fan is very dangerous which may harm human beings.
- When need maintenance and repairment, call dealer to handle it.
Incorrect maintenance and repairment may cause water leak, electrical shock and fire hazard.
- Air-conditioner can't be installed in the environment with inflammable gases because the inflammable gases near air-conditioner may cause fire hazard.
Please let the dealer be responsible for installing the conditioner. Incorrect installation may cause water leak, electrical shock and fire hazard.
- Call the dealer to take measures to prevent the refrigerant from leaking.
If conditioner is installed in a small room, be sure to take every measure in order to prevent suffocation accident even in case of refrigerant leakage.
- When conditioner is installed or reinstalled, the dealer should be responsible for them.
Incorrect installation may cause water leaking, electrical shock and fire hazard.
- Connect earthing wire.
Earthing wire should not be connected to the gas pipe, water pipe, lightning rod or phone line, incorrect earthing may cause shock.



Earthing

Before Installing (Relocating) the Unit or Performing Electric Work

⚠ Caution

Ground the unit.

- Do not connect the grounding on the unit to gas pipes, water pipes, lightning rods, or the grounding terminals of telephones. Improper grounding presents a risk of electric shock, smoke, fire, or the noise caused by improper grounding may cause the unit to malfunction.

Make sure the wires are not subject to tension.

- If the wires are too taut, they may break or generate heat and/or smoke and cause fire.

Install a explosion-proof breaker for current leakage at the power source to avoid the risk of the electric shock.

- Lack of a breaker for current leakage can pose risks of electric shock, fire, or explosion.
- Do not use large-capacity fuses, steel wire, or copper wire. Damaging the unit, fire, smoke or explosion will be caused otherwise.

Do not spray water on the air conditioners or immerse the air conditioners in water.

- Water on the unit presents a risk of electric shock. Periodically check the platform on which is placed for damage to prevent the unit from falling.

- If the unit is left on a damaged platform, it may topple over, causing injury.

When installing draining pipes, follow the instructions in the manual, and make sure that they properly drain water so as to avoid dew condensation.

- If not installed properly, they may cause water leaks and damage the furnishings.

Properly dispose of the packing materials.

- Things such as nails may be included in the package. Dispose of them properly to prevent injury. Plastic bags present a choking hazard to children. Tear up the plastic bags before disposing of them to prevent accidents.

Before the Test Run

⚠ Caution

Do not operate switches with wet hands to avoid electric. Do not touch the refrigerant pipes with bare hands during and immediately after operation.

- Depending on the state of the refrigerant in the system, certain parts of the unit such as the pipes and compressor may become very cold or hot and may subject the person to frost bites or burning.

Do not operated the unit without panels and safety guards in their proper places.

- They are there to keep the users from injury from accidentally touching rotating, high-temperature or high-voltage parts.

Do not turn off the power immediately after stopping the unit.

- Allow for at least five minutes before turning off the unit, otherwise the unit may leak water or experience other problems.

Do not operate the unit without air filters.

- Dust particles in the air may clog the system and cause malfunction.

Read Before Installation

Items to Be Checked

- (1). Verify the type of refrigerant used by the unit to be serviced. Refrigerant Type: R32
- (2). Check the symptom exhibited by the unit to be serviced. Look in this service handbook for symptoms relating to the refrigerant cycle.
- (3). Be sure to carefully read the safety precautions at the beginning of this document.
- (4). If there is a gas leak or if the remaining refrigerant is exposed to an open flame, a noxious gas hydrofluoric acid may form. Keep workplace well ventilated.

CAUTION

- Install new pipes immediately after removing old ones to keep moisture out of the refrigerant circuit.
- Chloride in some types of refrigerants such as R22 will cause the refrigerating machine oil to deteriorate.

Necessary Tools and Materials

Prepare the following tools and materials necessary for installing and servicing the unit.

Necessary tools for use with R32 (Adaptability of tools that are for use with R22 and R407C).

1. To be used exclusively with R32 (Not to be used if used with R22 or R407C)

Tools/Materials	Use	Notes
Gauge Manifold	Evacuating, refrigerant charging	5.09MPa on the High-pressure side.
Charging Hose	Evacuating, refrigerant charging	Hose diameter larger than the conventional ones.
Refrigerant Recovery Equipment	Refrigerant recovery	
Refrigerant Cylinder	Refrigerant charging	Write down the refrigerant type. Pink in color at the top of the cylinder.
Refrigerant Cylinder Charging Port	Refrigerant charging	Hose diameter larger than the conventional ones.
Flare Nut	Connecting the unit to piping	Use Type-2 Flare nuts.

2. Tools and materials that may be used with R32 with some restrictions

Tools/Materials	Use	Notes
Gas leak detector	Detection of gas leaks	The ones for HFC type refrigerant may be used.
Vacuum Pump	Vacuum drying	May be used if a reverse flow check adaptor is attached.
Flare Tool	Flare machining of piping	Changes have been made in the flare machining dimension. Refer to the next page.
Refrigerant Recovery Equipment	Recovery of refrigerant	May be used if designed for use with R32.

3. Tools and materials that are used with R22 or R407C that can also be used with R32

Tools/Materials	Use	Notes
Vacuum Pump with a Check Valve	Vacuum drying	
Bender	Bending pipes	
Torque Wrench	Tightening flare nuts	Only $\phi 12.70$ (1/2") and $\phi 15.88$ (5/8") have a larger flare machining dimension.
Pipe Cutter	Cutting pipes	
Welder and Nitrogen Cylinder	Welding pipes	
Refrigerant Charging Meter	Refrigerant charging	
Vacuum Gauge	Checking vacuum degree	

4. Tool and materials that must not be used with R32

Tools/Materials	Use	Notes
Charging Cylinder	Refrigerant Charging	Must not be used with R32-type units.

Tools for R32 must be handled with special care, and keep moisture and dust from entering the cycle.

Read Before Installation

Piping Materials

Types of Copper Pipes (Reference)

Maximum Operation Pressure	Applicable Refrigerants
3.4MPa	R22, R407C
4.3 MPa	R32

- Use pipes that meet the local standards.

Piping Materials/Radial Thickness

Use pipes made of phosphorus deoxidized copper.

Since the operation pressure of the units that use R32 is higher than that of the units for use with R22, use pipes with at least the radial thickness specified in the chart below. (Pipes with a radial thickness of 0.7mm or less may not be used.)

Size(mm)	Size(inch)	Radial Thickness(mm)	Type
Φ 6.35	1/4"	0.8t	Type-O pipes
Φ 9.52	3/8"	0.8t	
Φ 12.7	1/2"	0.8t	
Φ 15.88	5/8"	1.0t	
Φ 19.05	3/4"	1.0t	Type-1/2H or Hpipes

- Although it was possible to use type-O for pipes with a size of up to Φ 19.05(3/4") with conventional refrigerants, use type-1/2H pipes for units that use R32.(Type-O pipes may be used if the pipe size is Φ19.05 and the radial thickness is 1.2t.)
- The table shows the standards in Japan. Using this table as a reference, choose pipes that meet the local standards.

Flare Machining (type-O and OL only)

The flare machining dimensions for units that use R32 is larger than those for units that use R22 in order to increase air tightness.

Flare Machining Dimension(mm)

External dimension of pipes	Size	Dimension A	
		R32	R22
Φ6.35	1/4"	9.1	9.0
Φ9.52	3/8"	13.2	13.0
Φ12.7	1/2"	16.6	16.2
Φ15.88	5/8"	19.7	19.4
Φ19.05	3/4"	24.0	23.3

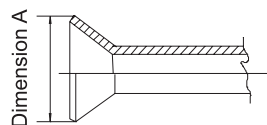

If a clutch type flare tool is used to machine flares on units that use R32, make the protruding part of the pipe between 1.0 and 1.5mm. Copper pipe gauge for adjusting the length of pipe protrusion is useful.

Flare Nut

Type-2 flare nuts instead of type-1 nuts are used to increase the strength. The size of some of the flare nuts have also been changed.

Flare nut dimension(mm)

External dimension of pipes	Size	Dimension B	
		R32 (Type2)	R22(Type1)
Φ6.35	1/4"	17.0	17.0
Φ9.52	3/8"	22.0	22.0
Φ12.7	1/2"	26.0	24.0
Φ15.88	5/8"	29.0	27.0
Φ19.05	3/4"	36.0	36.0

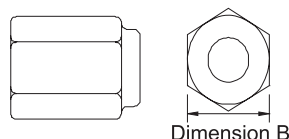

- The table shows the standards in Japan. Using this table as a reference, choose pipes that meet the local standards.

Read Before Installation

Air Tightness Test

No changes from the conventional method. Note that a refrigerant leakage detector for R22 or R410A cannot detect R32 leakage.

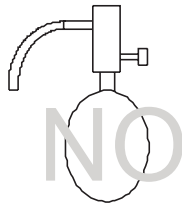

Halide torch

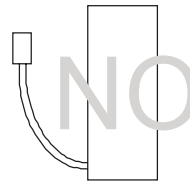

R22 or R407C leakage detector

Items to be strictly observed :

1. Pressurize the equipment with nitrogen up to the design pressure and then judge the equipment's air tightness, taking temperature variations into account.
2. When investigating leakage locations using a refrigerant, be sure to use R32 .
3. Ensure that R32 is in a liquid state when charging.

Reasons:

1. Use of oxygen as the pressurized gas may cause an explosion.
2. Charging with R32 gas will lead the composition of the remaining refrigerant in the cylinder to change and then this refrigerant can not be used.

Vacuumping

1. Vacuum pump with check valve

A vacuum pump with a check valve is required to prevent the vacuum pump oil from flowing back into the refrigerant circuit when the vacuum pump power is turned off (power failure). It is also possible to attach a check valve to the actual vacuum pump afterwards.

2. Standard degree of vacuum for the vacuum pump

Use a pump which reaches 65Pa or below after 5 minutes of operation.

In addition, be sure to use a vacuum pump that has been properly maintained and oiled using the specified oil. If the vacuum pump is not properly maintained, the degree of vacuum may be too low.

3. Required accuracy of the vacuum gauge

Use a vacuum gauge that can measure up to 650Pa. Do not use a general gauge manifold since it cannot measure a vacuum of 650Pa.

4. Evacuating time

Evacuate the equipment for 1 hour after 650Pa has been reached.

After envacuating, leave the equipment for 1 hour and make sure the that vacuum is not lost.

5. Operating procedure when the vacuum pump is stopped

In order to prevent a backflow of the vacuum pump oil, open the relief valve on the vacuum pump side or loosen the charge hose to drawn in air before stopping operation. The same operating procedure should be used when using a vacuum pump with a check valve.

Charging Refrigerant

R32 must be in a liquid state when charging.

Reasons:

R32 is a HFC refrigerant (boiling point = -52°C) and can roughly be handled in the same way as R410A; however, be sure to fill the refrigerant from the liquid side, for doing so from the gas side will somewhat change the composition of the refrigerant in the cylinder.

Note

- In the case of a cylinder with a syphon, liquid R32 is charged without turning the cylinder up side down. Check the type of cylinder before charging.

Remedies to be taken in case of a refrigerant leak

When refrigerant leaks, additional refrigerant may be charged. (Add the refrigerant from the liquid side)

Characteristics of the Conventional and the New Refrigerants

- Because R32 is a simulated azeotropic refrigerant, it can be handled in almost the same manner as a single refrigerant such as R22. However, if the refrigerant is removed in the vapor phase, the composition of the refrigerant in the cylinder will somewhat change.
- Remove the refrigerant in the liquid phase. Additional refrigerant may be added in case of a refrigerant leak.

1. Accessories

"Edging" for protection of electrical wires from an opening edge.

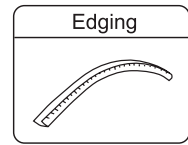

2. Selection of the place of installation

Select the place of installation satisfying the following conditions and, at the same time, obtain a consent from the client or user.

- Place where air circulates.
- Place free from heat radiation from other heat sources.
- Place where drain water may be discharged.
- Place where noise and hot air may not disturb the neighborhood.
- Place where there is not heavy snowfall in the winter time.
- Place where obstacles do not exist near the air inlet and air outlet .
- Place where the air outlet may not be exposed to a strong wind.
- Place surrounded at four sides are not suitable for installation. A 1m or more of overhead space is needed for the unit.
- Avoid mounting guide-louvers to the place where short-circuit is a possibility.
- When installing several units, secure sufficient suction space to avoid short circuiting.

Open space requirement around the unit

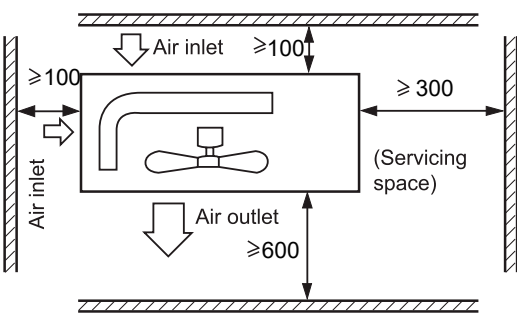

Note :

- (1) Fix the parts with screws.
- (2) Don't intake the strong wind directly to the outlet air-flow hole.
- (3) A one meter distance should be kept from the unit top.
- (4) Don't block the surroundings of the unit with sundries.
- (5) If the outdoor unit is installed in a place that is exposed to the wind, install the unit so that the outlet grid is NOT pointing in the direction of the wind.

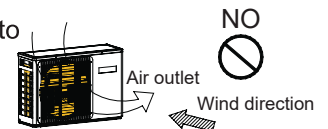

3. Installation of outdoor unit

Fix the unit on the foundation in a proper way according to the condition of the installation place, referring to the following information.

- Give enough room for the concrete foundation to fix by anchor bolts.
- Place the concrete foundation deep enough.
- Install the unit so that the angle of inclination must be less than 3 degrees.
- Forbidden to place the unit on the ground directly. Please confirm there is enough room near the drainage hole on bottom plate, which will ensure the water be drained smoothly.

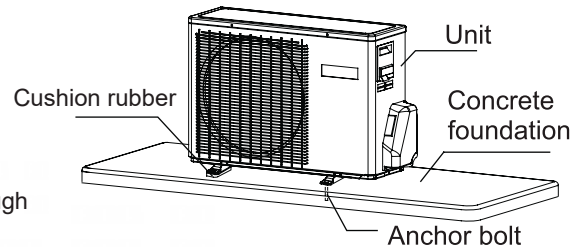

4. Installation dimension(Unit:mm)

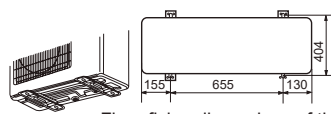
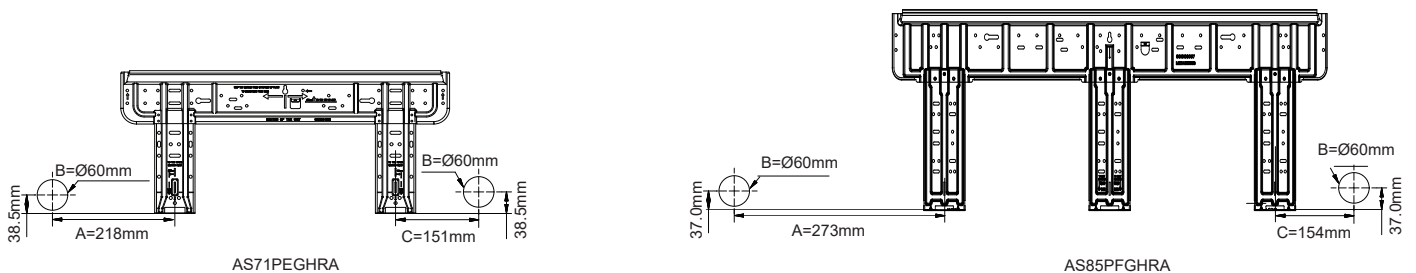

Floor fixing dimensions of the outdoor unit (Unit:mm)

1U71XAGFRA 1U85XAGFRA

1. Piping size

FOR AS71PEGHRA/1U71XAGFRA AS85PFGHRA/1U85XAGFRA	Liquid pipe	φ 6.35x0.8mm
	Gas pipe	φ 15.88x0.8mm

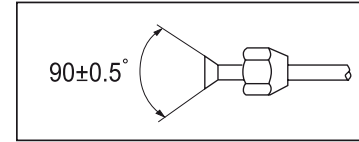

- Install the removed flare nuts to the pipes to be connected, then flare the pipes.

2. Connection of pipes

- When bending the pipe, avoid crushing it and prevent sharp bends to prevent breakage.
- Use a radius of curvature of 40 mm or more when bending the pipe.
- Start by connecting the gas side pipe first for easier work.
- Use specialized connection pipes designed for R32 refrigerant.

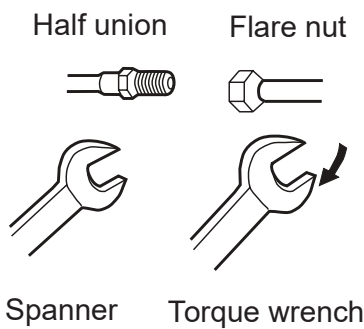

Forced fastening without proper centering can damage threads, resulting in gas leakage.

Pipe Diameter(φ)	Fastening torque
Liquid side 6.35mm(1/4")	18N.m
Liquid/Gas side 9.52mm(3/8")	42 N.m
Gas side 12.7mm(1/2")	55N.m
Gas side 15.88mm(5/8")	60 N.m

Be cautious to prevent foreign matter such as sand, water, etc. from entering the pipe.

CAUTION:

The standard pipe length is C meters. If the pipe needs to be lengthened, refrigerant should be charged at a rate of D grams per meter. However, refrigerant charging must be performed by a professional air conditioner engineer. Before adding additional refrigerant, purge air from the refrigerant pipes and indoor unit using a vacuum pump, then charge the additional refrigerant.

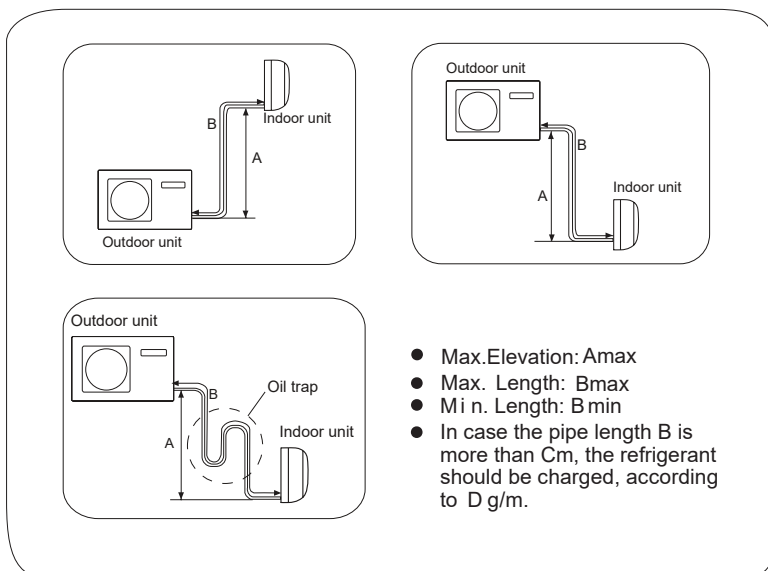

Outdoor Unit	Amax	Bmax	Bmin	C	D
1U71XAGFRA 1U85XAGFRA	30	50	3	10	27.5

After completing the connection of the refrigerant pipe, an air tightness test should be conducted.

- Use a nitrogen tank to pressurize according to the pipe connection mode as shown in the diagram.
- Ensure that both the gas and liquid valves are closed. Before pressurizing to prevent nitrogen from entering the outdoor unit's circulation system, tighten the valve rods (both gas and liquid valve rods).

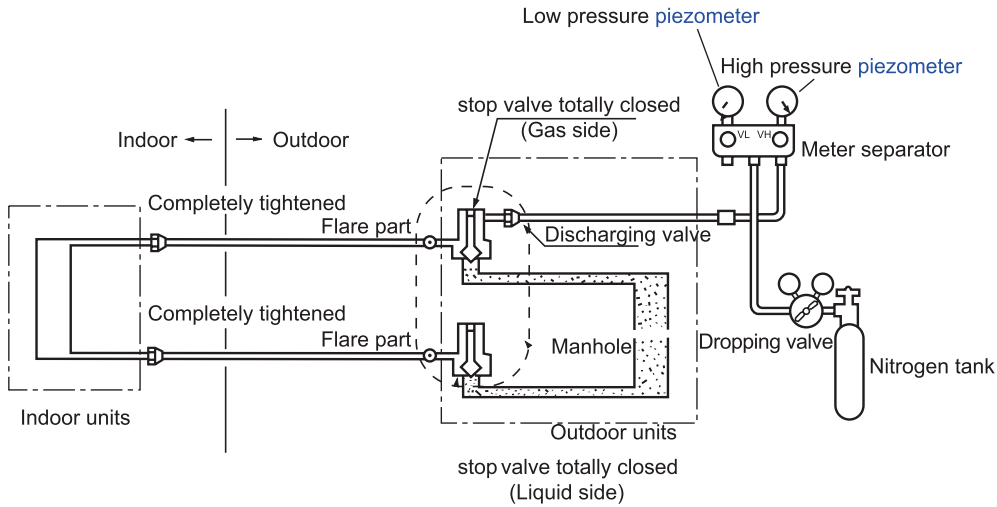

- 1) Pressurize for over 3 minutes at 0.3 MPa (3.0 kg/cm²g).
- 2) Pressurize for over 3 minutes at 1.5 MPa (15 kg/cm²g). Large leakage will be detected.
- 3) Pressurize for about 24 hours at 3.0 MPa (30 kg/cm²g). Small leakage will be detected.

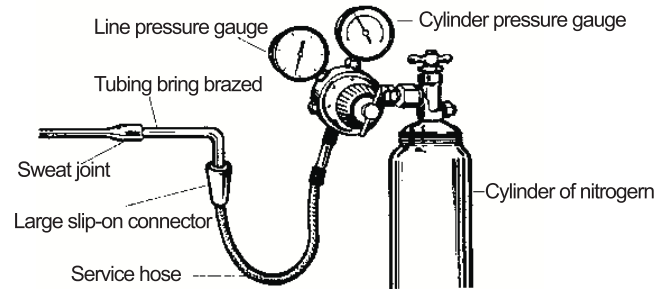

- Tubing is brazed.
- Check if the pressure drops using the service hose.
 - If pressure remains stable, pass.
 - If pressure drops, check for the leaking point.
 - During the 24-hour pressure test, a 1°C variation in ambient temperature will cause a 0.01 MPa (0.1 kg/cm²g) pressure variation, which should be corrected during the test.
- Checking for leaks:
 - In steps 1 to 3, if pressure drops, check for leaks at each joint by listening, touching, and using soap water. After identifying the leak, re-weld or tighten the nut securely.

Piping vavuum method: to use vacuum pump

1. Detach the service port's cap of 3-way valve, the valve rod's cap for 2-way valve and 3-way valves, and connect the service port into the projection of charge hose (low) for gaugemanifold. Then connect the projection of charge hose (center) for gaugemanifold into vacuum pump.

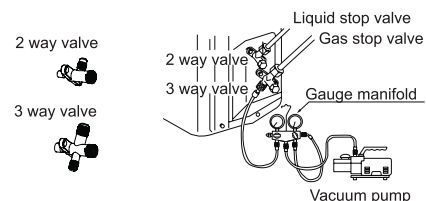

2. Open the low-pressure handle on the gauge manifold. Start the vacuum pump. If the gauge needle on the low-pressure side quickly moves to indicate a vacuum condition, double-check step 1.

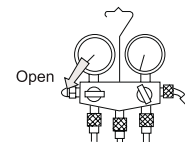

3. Evacuate the system for over 15 minutes. Check the level gauge, which should read approximately -0.1 MPa (-76 cm Hg) on the low-pressure side. Once evacuation is complete, close the "Lo" handle on the vacuum pump. Check the gauge's condition and hold it for 1-2 minutes. If the gauge needle moves back despite tightening, redo the flaring work, then repeat step 3 from the beginning.

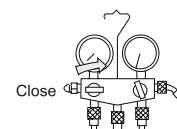

4. Open the valve for the 2-way valve to an angle of anticlockwise 90 degree. After 6 seconds, close the 2-way valve and make the inspection of gas leakage.

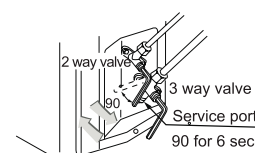

5. If there is no gas leakage, proceed to the next step. In the event of gas leakage, tighten the pipe connection parts. If the leakage stops, continue to step 6. If the leakage persists despite tightening, release all refrigerants from the service port. After redoing the flaring work, refill the prescribed refrigerant from the gas cylinder.

6. Detach the charge hose from the service port, then open both the 2-way valve and the 3-way valve. Turn the valve rod anticlockwise until it lightly hits.

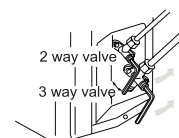

7. To prevent gas leakage, tighten the service ports cap, the valve rod's cap for the 2-way valve, and the 3-way's slightly beyond the point where the torque suddenly increases.

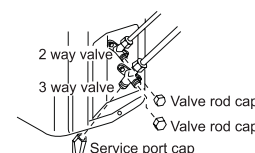

CAUTION:

If there's a refrigerant leak in the air conditioner, it's necessary to remove all the refrigerant. First, evacuate the remaining liquid refrigerant from the air conditioner according to the amount specified on the nameplate.

WARNING!

DANGER OF BODILY INJURY OR DEATH

- TURN OFF ELECTRIC POWER AT CIRCUIT BREAKER OR POWER SOURCE BEFORE MAKING ANY ELECTRIC CONNECTIONS.
- GROUND CONNECTIONS MUST BE COMPLETED BEFORE MAKING LINE VOLTAGE CONNECTIONS.

Precautions for Electrical wiring

- Electrical wiring work should be conducted only by authorized personnel.
- Do not connect more than three wires to the terminal block. Always use round type crimped terminal lugs with insulated grip on the ends of the wires.
- Use copper conductor only.

Selection of size of power supply and interconnecting wires

Select wire sizes and circuit protection from table below. (This table shows 20 m length wires with less than 2% voltage drop.)

Item Model	Phase	Minimum Circuit Breaker (A)
1U71XAGFRA 1U85XAGFRA	1	25

* Note: The circuit breaker must comply with local/national wiring regulations and be appropriate for the conductors used and their method of installation.

- If the supply cord is damaged, it must be replaced by the manufacturer or its service agent or a similar qualified person.
- If the fuse of control box is broken, please change it with the ceramic type of AC 250V, T30A.
- The wiring method should be in line with the local wiring standard.
- All the cables shall have got the local authentication certificate. During installation, when the connecting cables break off, it must be assured that the grounding wire is the last one to be broken off.
- The explosion-proof breaker of the air conditioner should be all-pole switch. The distance between its two contacts should not be less than 3mm. Such means for disconnection must be incorporated in the fixed wiring.
- The distance between its two terminal blocks of indoor unit and outdoor unit should not be over 5m. If exceeded, the diameter of the wire should be enlarged according to the local wiring standard.
- A explosion-proof breaker must be installed.

Wiring procedure

- 1) Remove set screws on the side before taking off the front panel toward the direction.
- 2) Connect wires to the terminal block correctly and fix the wires with a wire clamp equipped nearby the terminal block.
- 3) Route the wires in a proper way and penetrate the wires through the opening for electrical wiring on the side panel.

WARNING:

INTERCONNECTING WIRES MUST BE WIRED ACCORDING TO FIGURE BELOW. INCORRECT WIRING MAY CAUSE EQUIPMENT DAMAGE.

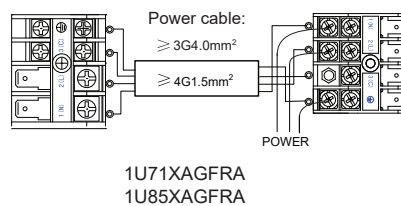

Model	7.1KW	8.5KW
Connecting wiring	4G1.5mm ²	4G1.5mm ²
Power cable	3G4.0mm ²	3G4.0mm ²

Outdoor Unit Troubleshooting

CAUTION!

- THIS UNIT WILL START IMMEDIATELY ONCE ELECTRIC POWER IS SUPPLIED, WITHOUT REQUIRING AN "ON" OPERATION. ENSURE TO PERFORM AN "OFF" OPERATION BEFORE DISCONNECTING ELECTRIC POWER FOR SERVICING.
- This unit has a function of automatic restart system after recovering power stoppage.

1. Before starting test run (for all Heat pump models)

Before conducting a test run for all heat pump models, ensure that the power source breaker (main switch) of the unit has been turned on for over 12 hours to energize the crankcase heater in advance of operation.

2. Test run

During the initial 30-minute run, carefully monitor the following parameters:

- Suction pressure at the check joint of the service valve for the gas pipe.
- Discharge pressure at the check joint on the compressor discharge pipe.
- Temperature difference between the return air and supply air for the indoor unit.

	Code indication			fault description
	Indoor displaying panel code indication		Outdoor (LED1 flash times)	
Indoor and Outdoor	E7	Directly display	15	Communication fault between indoor and outdoor units
Indoor Malfunction	E1	Directly display	/	Indoor temperature sensor failure
	E2	Directly display	/	Indoor coil sensor failure
	E4	Directly display	/	Indoor eeprom failure
	E14	Directly display	/	Indoor fan failure
Outdoor Malfunction	E5	Trouble record	22	Internal unit antifreeze protection
	E9	Trouble record	21	Internal unit overload
	F12	Directly display	1	Eeprom failure
	F1	Directly display	2	IPM failure
	F22	Directly display	3	AC current overcurrent protection
	F3	Directly display	4	Communication error between module board and main PCB board.
	F20	Trouble record	5	High pressure protection
	F19	Trouble record	6	Power over/under voltage protection
	F27	Directly display	7	Compressor stall / press instantaneous stop
	F4	Directly display	8	Compressor discharging temperature protection
	F8	Trouble record	9	Abnormal of DC motor
	F21	Directly display	10	Abnormal of piping sensor
	F7	Directly display	11	Suction temperature sensor failure
	F6	Directly display	12	Abnormal of outdoor ambient sensor
	F25	Directly display	13	Abnormal of compressor discharge sensor
	F13	Trouble record	16	Lack of refrigerant
	F14	Trouble record	17	4-way valve reverse failure
	F11	Directly display	18	Compressor jam (only for spdu)
	F28	Directly display	19	Module PWM select circuit error
	F15	Trouble record	20	Outdoor terminal block temperature protection
	F2	Trouble record	24	Instantaneous over-current protection of the compressor
	F23	Trouble record	25	Compressor U-phase overcurrent Compressor V-phase overcurrent Compressor W-phase overcurrent
	F9	Trouble record	26	Module reset
F24	Trouble record	27	CT disconnection	
F34	Trouble record	37	Outdoor coil protection	
F35	Trouble record	38	Compressor driver board failure	
F43	/	46	Model matching abnormality	

Customer Care

Visit the website for more information

Australia: haierhome.com.au

New Zealand: haierhome.co.nz

Customer support and service

booking Australia: 1300 729 948

New Zealand: 0800 424 372

Important notice of Disclosure: Copyright © Fisher & Paykel Appliances 2024. All rights reserved. The product dimensions and specifications in this document apply to the specific products and models described at the date of issue. Under our policy of continuous product improvement, these dimensions and specifications may change at any time. You should therefore check with your dealer or Haier's Customer Care Centre to ensure this flyer correctly describes the products currently available.

Fisher & Paykel Appliances Australia Level 1, 1 Eden Park Drive, Macquarie Park, NSW 2113.

New Zealand: Fisher & Paykel Appliances Ltd, 78 Springs Road, East Tamaki, Auckland 2013.

Haier