

Product Brochure

CHILLER

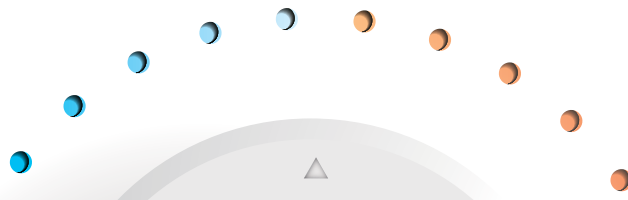

Haier
Air Conditioning



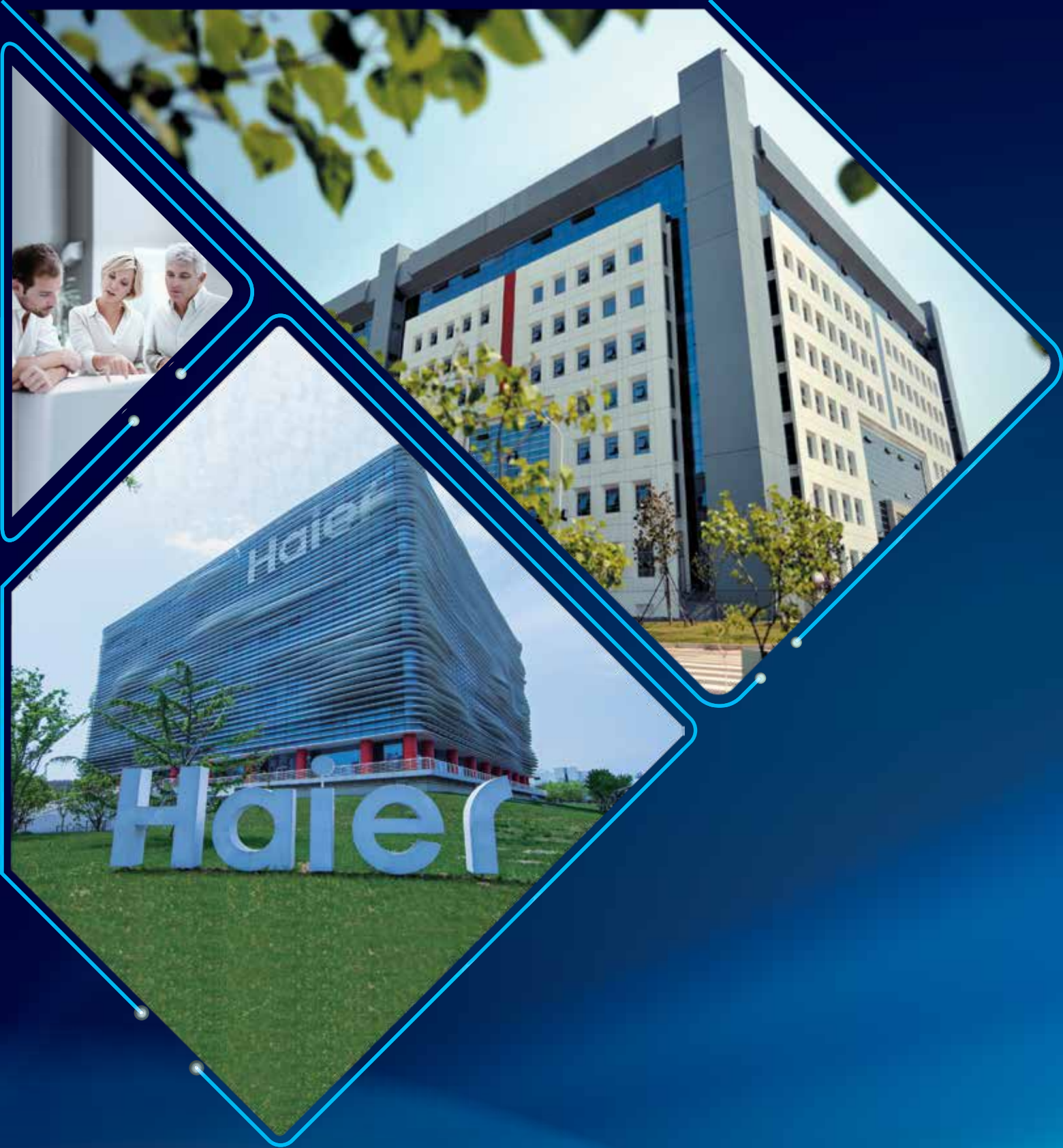

Haier Brand Story

The Internet era is a diverse and unconventional time, where "one size fits all" products and solutions simply isn't enough. Customers want to be treated as individuals and respected for who they are. Everyone wants their unique lifestyle acknowledged. That is why Haier listens closely to you in order to gain a genuine understanding of what is going on in your life and what is on your mind. So each of you can get the smart home experience you deserve: be it simple, sophisticated, organized or enjoyable. As a worldwide industry leader, Haier innovates beyond products and solutions and turns the organization into a wholly connected platform. In doing so, internal and external resources are connected quickly and easily. We believe only by doing so, we can best meet our consumers' expectations in this rapidly evolving world. Be part of the Haier Network. Create new possibilities.

Haier Global Network

From introduction to absorption, from manufacture to creation, Haier has been accomplishing a goal of creating a world-renowned brand step over the past 30 years. Haier boasts 66 trading companies, 10 design R&D Centers, 108 manufacturing bases and 24 innovative industrial parks across the world with a global selling network comprised of 143,300 sales outlets spanning more than 100 countries. With more than 73 thousand employees worldwide, Haier has now established a "Three in one" network layout.



Haier Global Revenue

Established in 1984, Haier is the world's No. 1 major appliance brand.

Claim: "Haier is the number one brand of major appliances in the world in volume sales"

Footnote: "Source Euromonitor International Limited; Consumer Appliances 2017ed, % unit share, 2016 data. Major Appliances category is the sum of dishwashers, home laundry appliances, large cooking appliances, microwaves and refrigeration appliances"

Commercial Air Conditioning Smart Interconnected Factory

On October 2016 the Haier commercial air conditioning smart interconnected factory was officially completed. This is the 8th interconnected factory of Haier. This factory has the production capacity of 10 types of commercial air conditioning products, takes advantages of the whole process information interconnected system, smart manufacture , smart detection and other technologies. Redefining the manufacturing standards of commercial air conditioning industry, to meet the increasing market demand. Leading the commercial air conditioning users into the era of personalized customization.



The **8th** interconnected factory of Haier

Project covers an area of **87,000 m²**, with a building area is **51,000 m²**

Have the production capacity of **10** types of commercial air conditioning products

Equipped with **8** final assembly lines and **4** modular areas

Maxium production & testing capability of **4500** tons

Overall energy saving reaches to **20%**, to create industry benchmark factory

Haier

Redefining manufacturer's standards, bring forth new ideas and lead industry to upgrade

The first large-scale customization interconnected factory



Haier's interconnected factory was born to meet the personalized needs of users. Through the front end of the interconnected factory to collect the fragmented demand of users, and flexible production is realized through smart manufacturing, which can solve the natural contradiction between mass production and personalised customization.

The first whole-process transparent interconnected factory in the world



The way Haier interconnect factory links to users is the visual production. Haier commercial air conditioning initiatively created the whole-process information interconnected system, by total factor and the end-to-end system to realize mass customization, and finally achieved the seamless, transparent and visualized user experience. Through real-time, accurate data, to meet the visualization demands of the lowest level information from the whole plant and even the global plants.

Leading the whole ecosystem big data system in the industry



Haier commercial air conditioning smart interconnected factory is not a concept of a factory, but an ecosystem of multiplied inner and outer circles. This ecosystem realizes real-time interconnected of the whole processes for users, they can participate in all processes from the design, manufacture, at the same time make zero distance from the user to the plant. The orders are sent directly to the factory, reducing intermediate links between the production and the order processing, and customized products can be directly delivered to the user.

Haier chiller history.

2003

The first magnetic bearing compressor was born in the world

2006

Haier high temperature Magnetic Bearing Centrifugal Chiller

2009

Haier magnetic bearing centrifugal water source heat pump

2011

Haier air-cooled magnetic bearing centrifugal chiller .





2013

Haier modular magnetic bearing centrifugal chiller . Small in size perfectly suited for renovation projects

2014

Haier magnetic bearing centrifugal chiller with cooling capacity of 2,210 tons .

2015

Haier magnetic bearing centrifugal chiller with failing film evaporator

2016

Haier Air-cooled magnetic bearing centrifugal chiller with free cooling.

Haier
Air Conditioning



OIL FREE CENTRIFUGAL CHILLER



Oil Free Centrifugal Chiller

Low Cost

Low maintenance cost

The unit adopts no oil in the chiller, so no oil contamination over time, and design efficiency is maintained effortlessly. This design can save maintenance costs during the life cycle, as there is no need to clean oil filters or remove oil deposits .

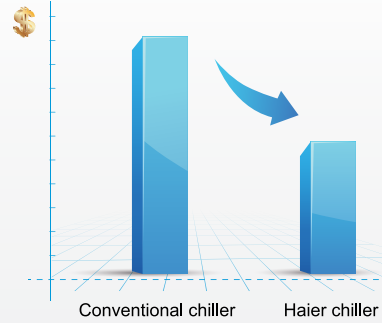

High Reliability

Longevity

Compressor is made from the aerial class aluminum mold and the high strength thermal plastic electronic case, which can keep the compressor running smoothly and efficiently..

Aerospace materials and technology, ensures reliable efficient operation.

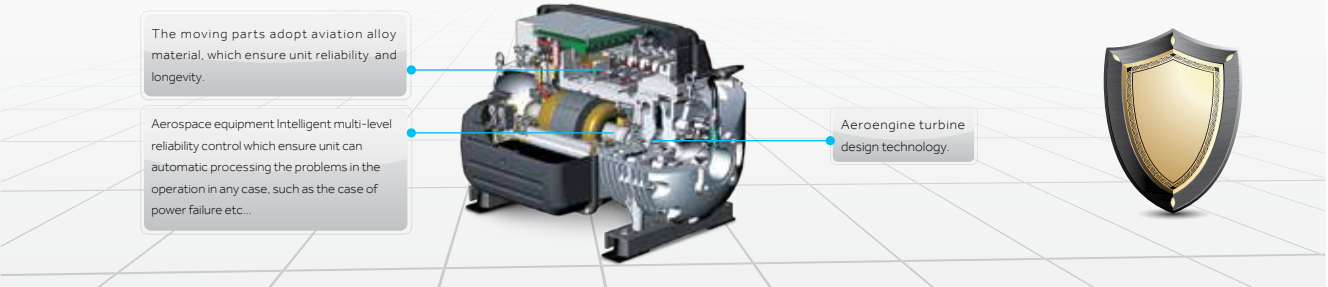

Compressor safe operation

Compressor control module will operate to the performance curves, adjust the running speed to ensure the compressor is running safely.

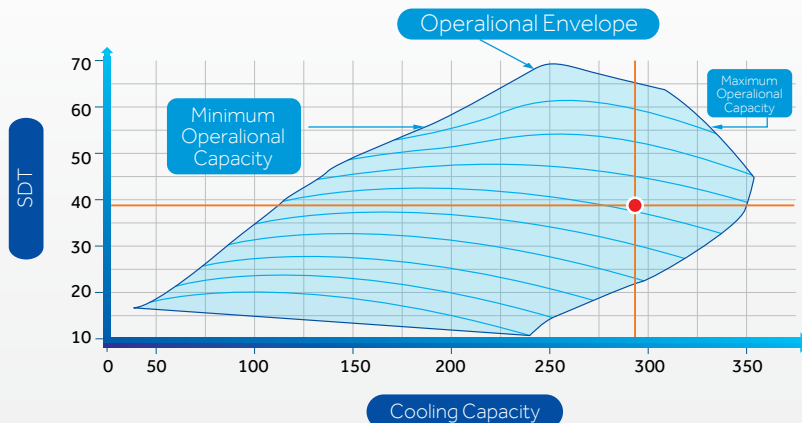

Comfort

Low noise and less vibration

Due to the oilless and magnetic bearing operation, the device vibration is very small. So Haier magnetic bearing centrifugal chiller does not need the anti-vibration mounts like other alternative compressor chiller. The 'water-cooled chiller' s running noise is lower than 75 dB(A), while the conventional chiller is higher.

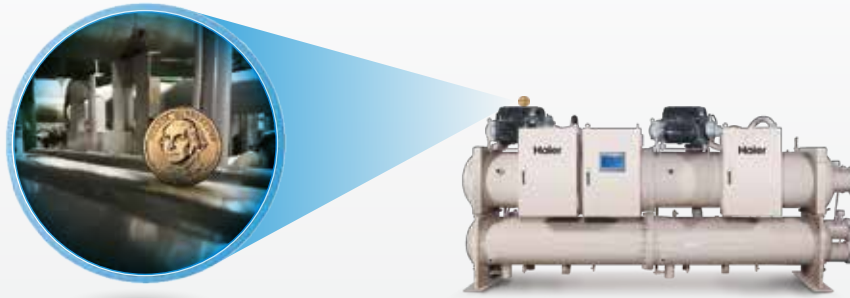

Flexible capacity adjustment

When condensing temperature goes down or the heat load is decreased, the compressor speed will be slower. The system controls the refrigerant output from 5%-100% of the rated load freely, optimizing the compressor efficiency.

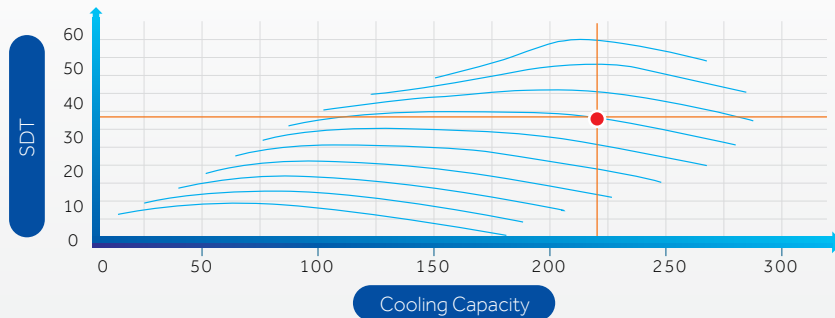

Convenience

Friendly operation screen

Big LCD touch screen. Chinese and English are selectable
Calendar / Fault inquires / Water system equipment interlocking / Remote control / Unit operation parameters quick inquiry



Oil Free Centrifugal Chiller

Advanced Technology

Compressor technology

- **Turbocor compressor technology**

The chillers either water-cooled or air-cooled, are designed to optimize the performance of the high efficient Danfoss Turbocor oil-free centrifugal compressor technology.

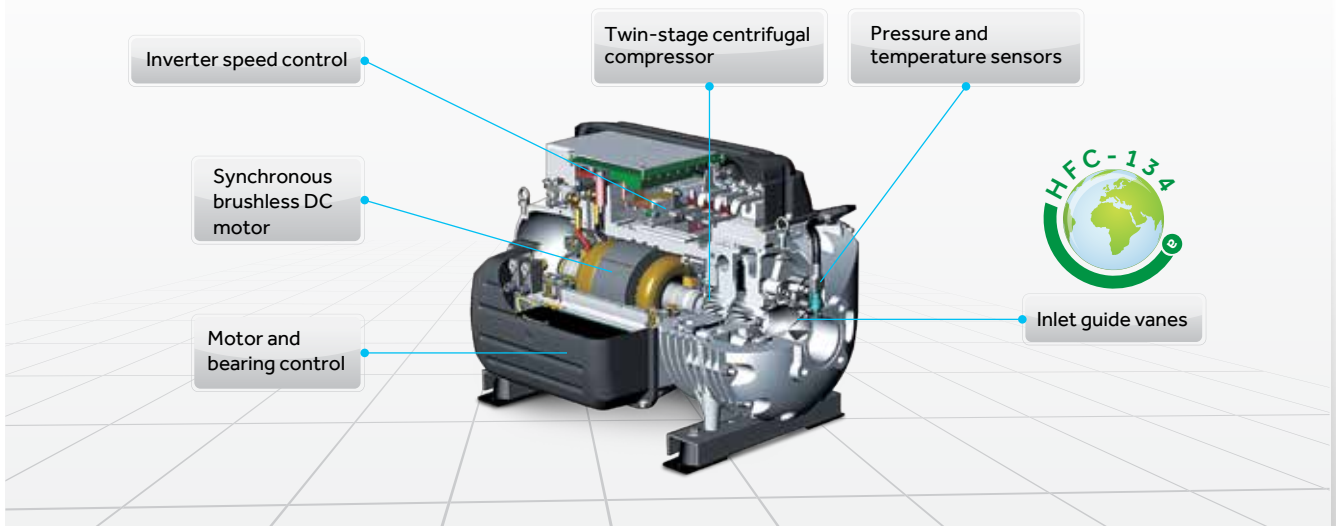

- **Magnetic bearing technology**

Magnetic bearing and orientation sensor: Two radial bearings and one axial bearing compose the digital magnetic bearing system. The movement parts are made of permanent magnet and electric magnet will suspend on the magnet and move without friction. The orientation sensor will confirm the precise position of the rotor at max.6,000,000 times per minute.

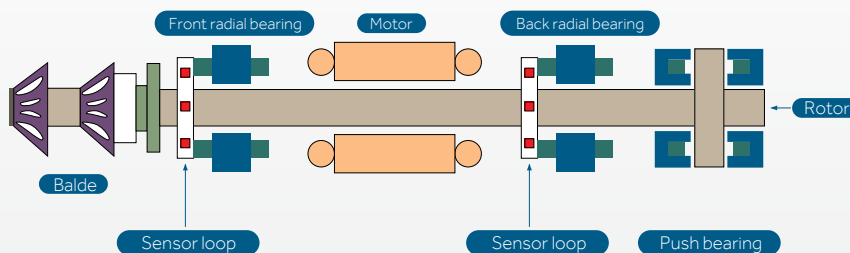

- **Permanent-magnet motor and Landing bearing**

The compressor motor is magnetic permanently, which is supplied voltage by PWM (pulse width management) to realize variable speed running. The landing bearing will go upward before the unit starts up, which will keep a certain distance automatically and ensure no friction.

The radial bearing is to bear the axis after the compressor is powered down, to avoid the touch between the axis and the other metal surface.



Advanced Technology

Compressor Technology

- **Inverter driving**

The inverter centrifugal compressor adopts the integrated driving module. on the condition of condensing temperature decreasing or load reducing, lower the compressor revolution, then optimum the compressor energy efficiency with 5%-100% of rated load.

Optional: digital load balancing valve, compressor even can work normally even when the load almost closes to 0.

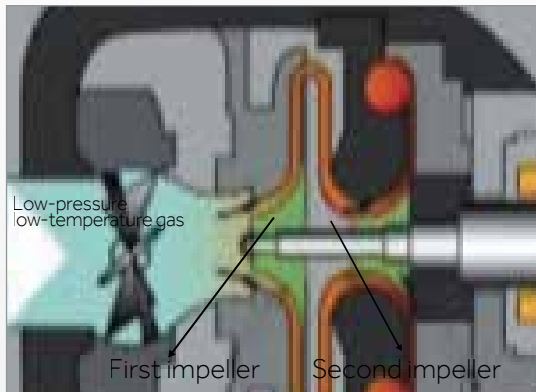

Two stage compression
load adaptive capacity is better

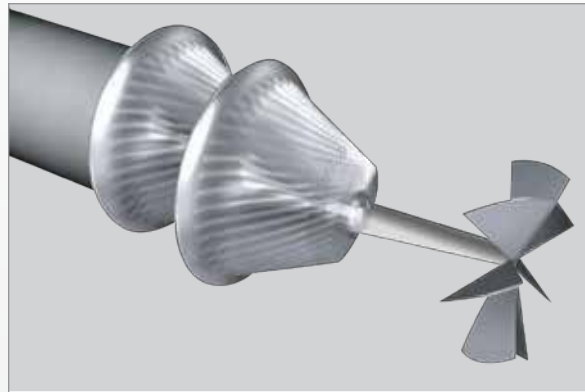

Intelligent dynamical inverter
save more energy

- **Frictionless system**

The movement parts of magnetic bearing system centrifugal compressor are composed of two radial magnetic bearings and one axial magnetic bearing. So the digital magnetic bearing system will be suspended when compressor is running. The movement parts do not need oil, which avoid that oil film in the heat exchanger lays on the pipe to reduce the heat exchanging efficiency. Thus it will ensure the product has the consistent excellent performance in its operation period.

The oil content of old type chiller is 9% on average, which will reduce the efficiency up to 15% to 20%. Haier's magnetic bearing system inverter centrifugal chiller can enhance efficiency over 15% because of oil-free lubrication system.

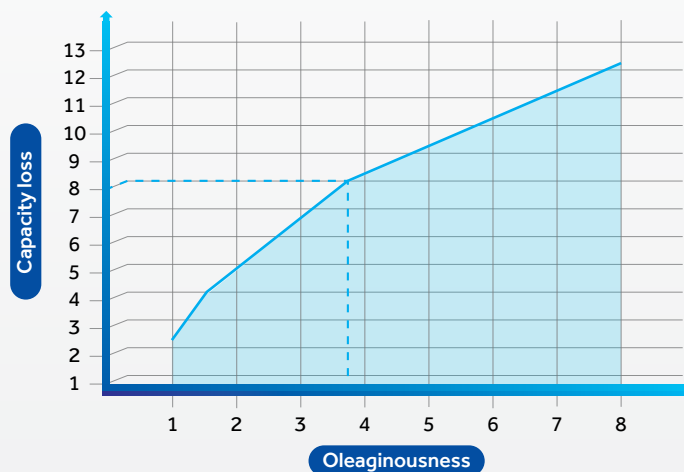

Oil Free Centrifugal Chiller

Advanced Technology

High efficiency heat exchanger

The water-cooled and air-cooled magnetic bearing centrifugal chillers adopt shell and tube flooded evaporator and shell and tube condenser, where applicable. The heat exchange tube adopts special layout to improve refrigerant flow in the evaporator /condenser to increase efficiency.

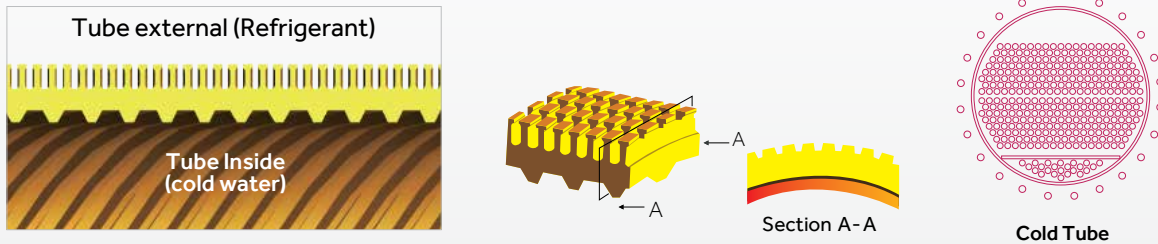

The modular water-cooled magnetic bearing centrifugal chillers adopt falling film evaporator to reduce the refrigerant charge and increase the heat exchange efficiency.

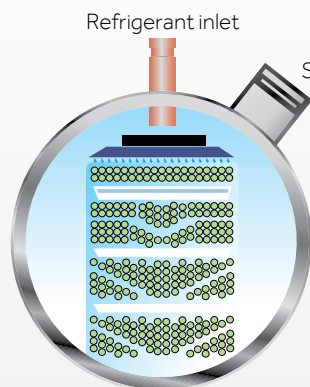

Fall film type

Refrigerant liquid film lays on copper evenly, air is separated from liquid perfectly to increase heat exchange efficiency greatly.

EXV design

The unit adopts electronic expansion valve to control the volume of liquid refrigerant spraying into the evaporator precisely. By controlling the stepping motor operation due to the different load, the special electronic expansion valve driving module can adjust open degree of valve to control refrigerant flow volume, reaching the optimum efficiency.

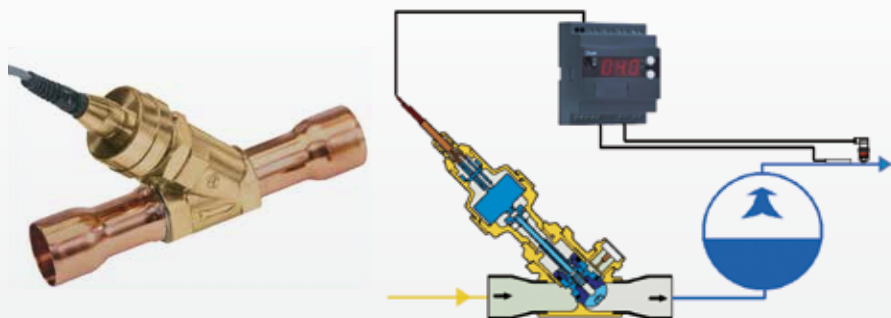

Advanced Technology

Economizer

The chillers are added with the economizer, which can improve degree of supercooling greatly, increasing efficiency.

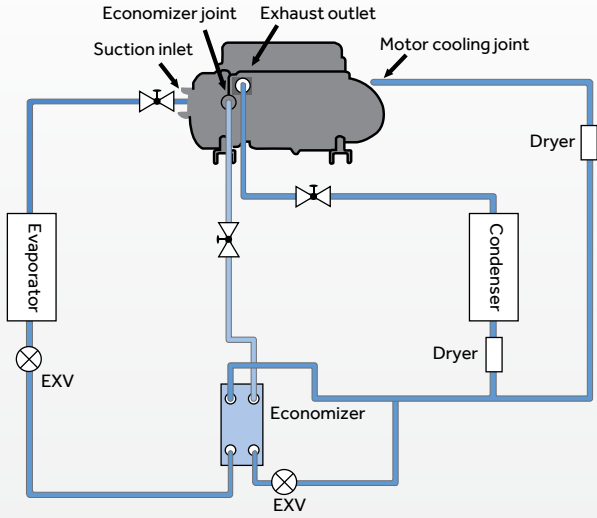

Air Cooled Oil Free Centrifugal Chiller

Air cooled cooling only
Cooling capacity range from 350kW up to 1760kW



* Picture is based on single compressor model

Options / Accessories

Accessories	Standard	Optional
Power supply	3/400V/50Hz	-
Cloud service	Yes	-
Communication protocol	Modbus	BACnet
EMC/EMT filter	Yes	-
Active power filter	Option extra	Yes
Water inlet/outlet connection type	Victaulic	Flange
"Epoxy" coating thickness of fin	0.11mm	0.15mm
Water side working pressure	1.0Mpa	1.6Mpa
Fan	AC fan	EC fan
Chilled water flow meter	X	Optional
Thermal insulation thickness	20mm	25mm/40mm

Specification

Model		CC0350PABI	CC0440PABI	CC0700PABI	CC0790PABI	CC0880PABI	
Combination		A	B	2*A	A+B	2*B	
Cooling capacity	kW	350	440	700	790	880	
Total Power input	KW	102	125	203	226	246.5	
COP	KW/kW	3.43	3.52	3.45	3.5	3.57	
Starting current(Compressor)	A	2	2	2	2	2	
Max. Running current	A	250	280	500	530	560	
Max. Power input	KW	148	166	296	314	332	
Power supply		3~/400V/50Hz					
Refrigerant throttle type		Electronic expansion valve					
Capacity control		10%-100%					
Safety protection		Compressor overload protection, safe protection, low water flow protection, anti-freezing protection, fan motor overload protection, lack of phase protection					
Compressor	Type	Magnetic bearing compressor					
	Quantity	1	1	2	2	2	
Refrigerant	Type	R134a					
	Charge	kg	220	255	440	475	510
Air side heat exchanger	Type	High efficiency copper tube+Hydrophilic aluminium foil					
	Fan type	Axial fan with low noise					
	Fan quantity	6	8	12	14	16	
Water side heat exchanger	Type	Flooded type					
	Rated water flow	m ³ /h	60	76	120	136	151
	Inlet/outlet pipe	DN	150	150	150	150	150
	Water dirt coefficient	m ² .°C/kW	0.0172				
Standard pressure		MPa	1				
Water side resistance		kPa	85	88	86	89	90
External dimension	Unit length	mm	4060	5260	7690	8890	10090
	Unit width	mm	2200	2200	2200	2200	2200
	Unit height	mm	2700	2700	2700	2700	2700
Weight	Net weight	kg	3400	3985	6840	7425	8010
	Gross weight	kg	3450	4050	6940	7540	8140
	Operation weight	kg	3500	4230	7080	7810	8540

Note:

1. Above parameters are based on the standard products;
2. Above products standard pressure is 1.0 Mpa, if pressure higher than 1.0 Mpa, should contact with Haier technology engineer;
3. Operating ambient temperature range :15-43°C
4. Except CC0350PANI/CC0440PANI model, all others are a combination of A/B and separately transported/fitted on site.
5. Due to our policy of innovation some specifications maybe changed without notification;

Air Cooled Oil Free Centrifugal Chiller

Model			CC1050PABI	CC1140PABI	CC1230PABI	CC1320PABI
Combination			3*A	2*A+B	A+2*B	3*B
Cooling capacity	kW		1050	1140	1230	1320
Total Power input	KW		303	325.5	348.5	364.6
COP	KW/kW		3.47	3.5	3.53	3.62
Starting current(Compressor)	A		2	2	2	2
Max. Running current	A		750	780	810	840
Max. Power input	KW		444	462	480	498
Power supply			3~/400V/50Hz			
Refrigerant throttle type			Electronic expansion valve			
Capacity control			10%~100%			
Safety protection			Compressor overload protection, safe protection, low water flow protection, anti-freezing protection, fan motor overload protection, lack of phase protection			
Compressor	Type		Magnetic bearing compressor			
	Quantity		3	3	3	3
Refrigerant	Type		R134a			
	Charge	kg	660	695	730	765
Air side heat exchanger	Type		High efficiency copper tube+Hydrophilic aluminium foil			
	Fan type		Axial fan with low noise			
	Fan quantity		18	20	22	24
Water side heat exchanger	Type		Flooded type			
	Rated water flow	m ³ /h	181	196	212	227
	Inlet/outlet pipe	DN	250	250	250	250
	Water dirt coefficient	m ² .°C/kW	0.0172			
Standard pressure		MPa	1			
Water side resistance		kPa	40	42	43	45
External dimension	Unit length	mm	11320	12520	13720	14920
	Unit width	mm	2200	2200	2200	2200
	Unit height	mm	2700	2700	2700	2700
Weight	Net weight	kg	10280	10865	11450	12035
	Gross weight	kg	10430	11030	11630	12230
	Operation weight	kg	10660	11390	12120	12850

Note:

1. Above parameters are based on the standard products;
2. Above products standard pressure is 1.0 Mpa, if pressure higher than 1.0 Mpa, should contact with Haier technology engineer;
3. Operating ambient temperature range :15~43°C
4. Except CC0350PANI/CC0440PANI model, all others are a combination of A/B and separately transported/fitted on site.
5. Due to our policy of innovation some specifications maybe changed without notification;

Specification

Model		CC1400PABI	CC1490PABI	CC1580PABI	CC1670PABI	CC1760PABI	
Combination		4A	3*A+B	2*A+2*B	A+3*B	4B	
Cooling capacity	KW	1400	1490	1580	1670	1760	
Total Power input	KW	400	423.8	445	462.6	482.2	
COP	KW/kW	3.5	3.52	3.55	3.61	3.65	
Starting current(Compressor)	A	2	2	2	2	2	
Max. Running current	A	1000	1030	1060	1090	1120	
Max. Power input	KW	592	610	628	646	664	
Power supply		3~/400V/50Hz					
Refrigerant throttle type		Electronic expansion valve					
Capacity control		10%~100%					
Safety protection		Compressor overload protection, safe protection, low water flow protection, anti-freezing protection, fan motor overload protection, lack of phase protection					
Compressor	Type	Magnetic bearing compressor					
	Quantity	4	4	4	4	4	
Refrigerant	Type	R134a					
	Charge	kg	880	915	950	985	1020
Air side heat exchanger	Type	High efficiency copper tube+Hydrophilic aluminium foil					
	Fan type	Axial fan with low noise					
	Fan quantity	24	26	28	30	32	
Water side heat exchanger	Type	Flooded type					
	Rated water flow	m ³ /h	241	256	272	287	303
	Inlet/outlet pipe	DN	250	250	250	250	250
	Water dirt coefficient	m ² .°C/kW	0.0172				
Standard pressure		MPa	1				
Water side resistance		kPa	75	78	80	86	90
External dimension	Unit length	mm	14950	16150	17350	18550	19750
	Unit width	mm	2200	2200	2200	2200	2200
	Unit height	mm	2700	2700	2700	2700	2700
Weight	Net weight	kg	13800	14385	14970	15555	16140
	Gross weight	kg	14000	14600	15200	15800	16400
	Operation weight	kg	14300	15030	15760	16490	17220

Note:

- Above parameters are based on the standard products;
- Above products standard pressure is 1.0 Mpa, if pressure higher than 1.0Mpa, should contact with Haier technology engineer;
- Operating ambient temperature range :15-43°C
- Except CC0350PANI/CC0440PANI model, all others are a combination of A/B and separately transported/fitted on site.
- Due to our policy of innovation some specifications maybe changed without notification;

Air Cooled Oil Free Centrifugal Chiller

Unit Dimension Diagram

CC0350PABI

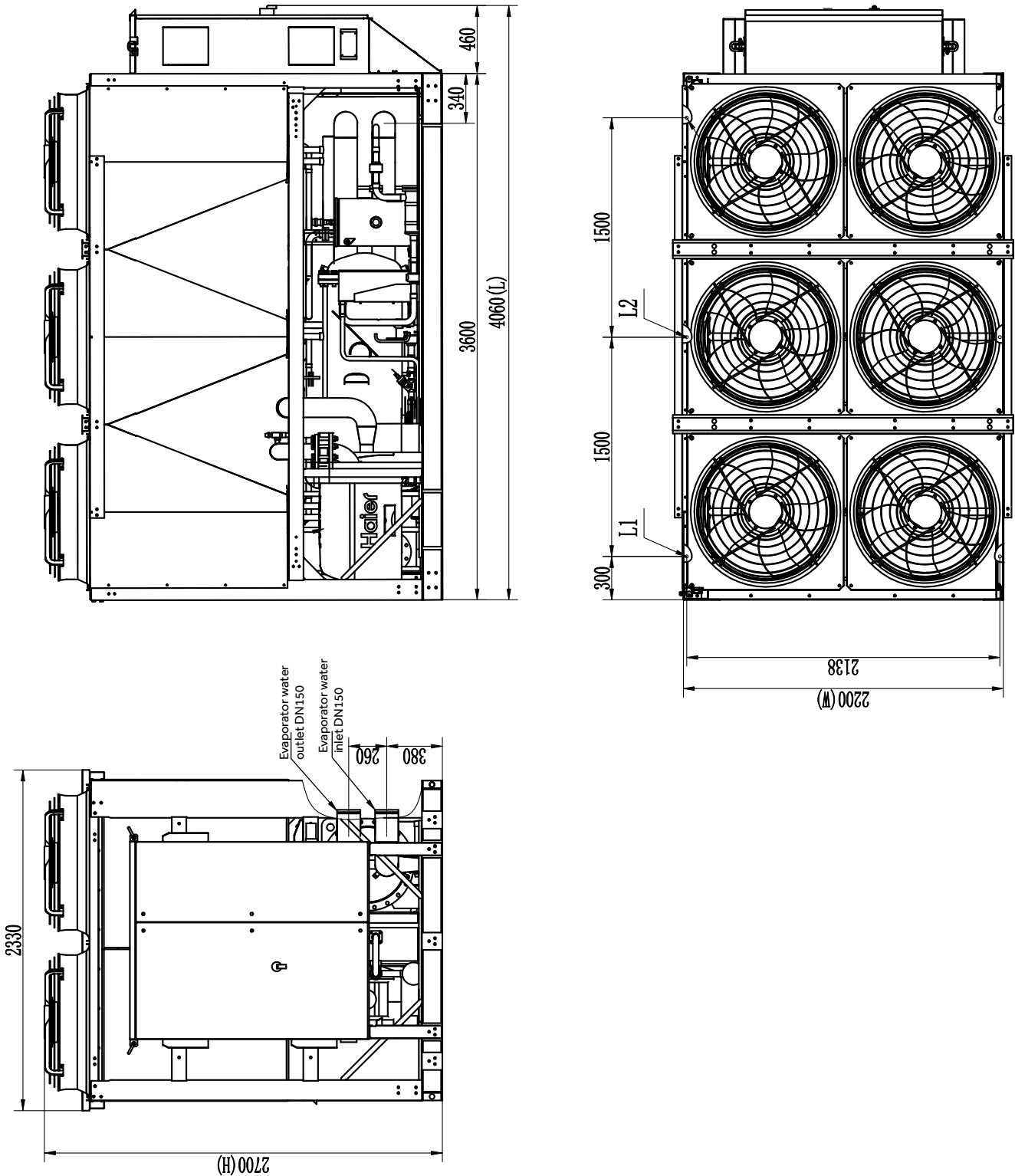

Unit Dimension Diagram

CC0440PABI

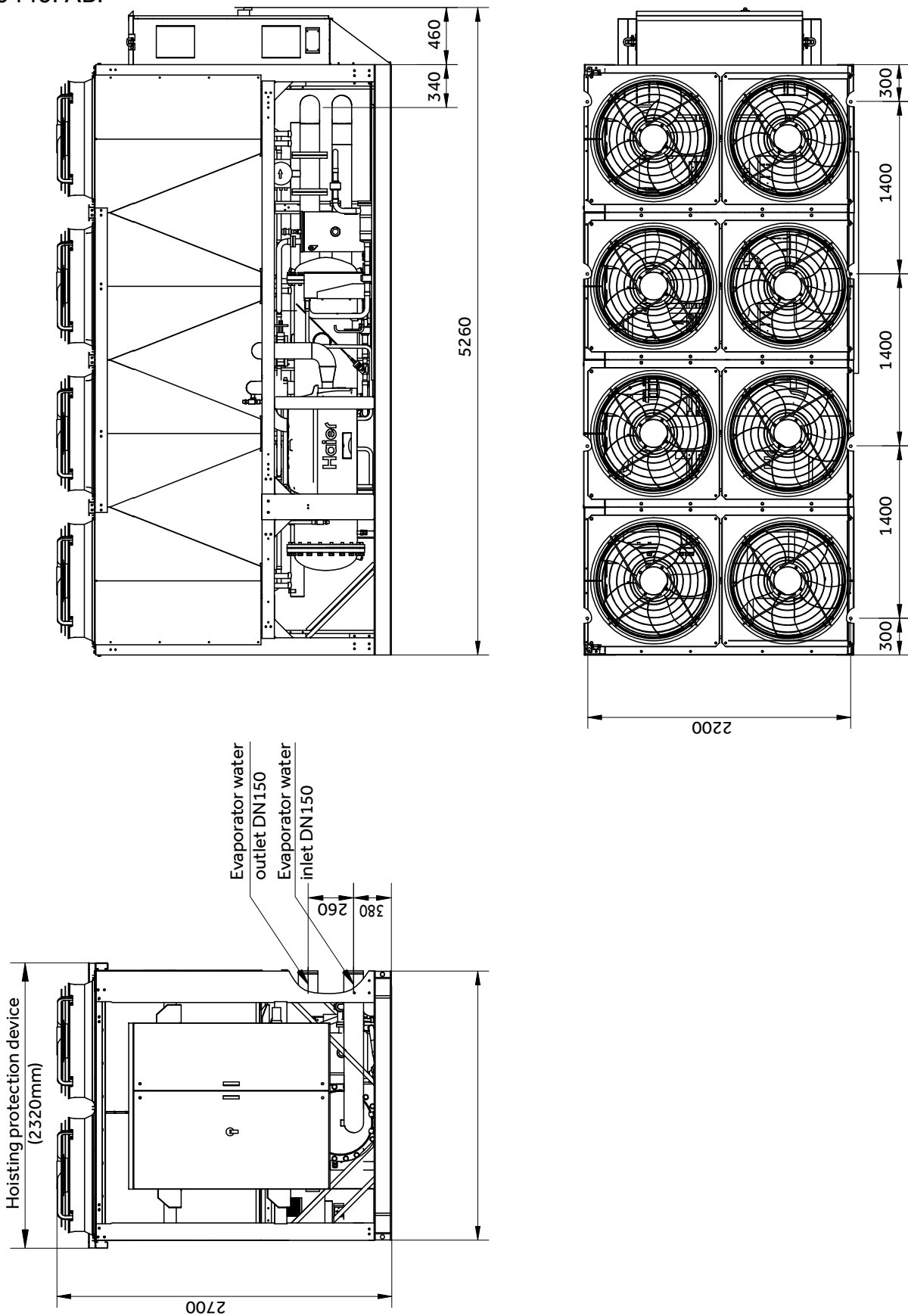

Air Cooled Oil Free Centrifugal Chiller

Unit Dimension Diagram

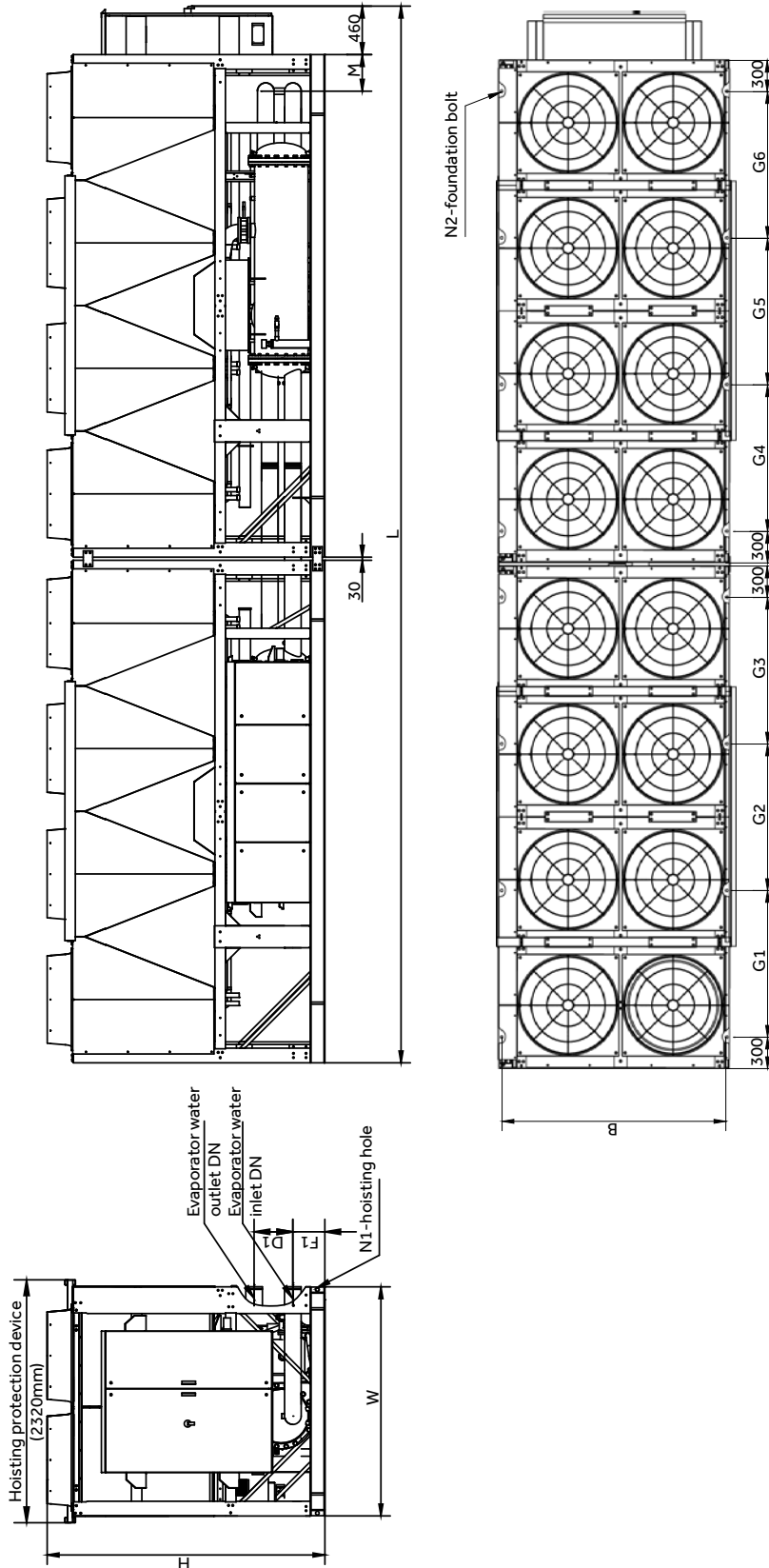

Model	Dimension mm			Installation dimension mm						Pipe connection dimension mm			Hoisting hole number	Foundation bolt number		
	L	W	H	G1	G2	G3	G4	G5	G6	D1	F1	M			DN	
CC0700PANI	7690	2200	2700	1500	1500	1500	1500	1500	1500	260	380	340	DN150	8	N1	12
CC0790PANI	8890	2200	2700	1500	1500	1400	1400	1400	1400	260	380	340	DN150	8	N1	14
CC0880PANI	10090	2200	2700	1400	1400	1400	1400	1400	1400	260	380	340	DN150	8	N1	16

Water Cooled Oil Free Centrifugal Chiller

Water cooled/Cooling only
Cooling capacity range from 440kW up to 7034kW



* Picture is based on single compressor model

Options / Accessories

Accessories		Standard	Optional
Power supply		3/400V/50Hz	-
Cloud service		Yes	-
Communication protocol		Modbus	BACnet
EMC/EMT filter		Yes	-
Active power filter		Option extra	Yes
Water inlet/outlet connection type		Victaulic	Flange
"Epoxy" coating thickness of fin		0.11mm	0.15mm
Water side working pressure		1.0Mpa	1.6Mpa
Fan		AC fan	EC fan
Chilled water flow meter		X	Optional
Thermal insulation thickness		20mm	25mm/40mm
Channel steel base			
Refrigeration cycle system	≤800RT	Modular refrigeration cycle system	In-corporative refrigeration cycle system
	>800RT	In-corporative refrigeration cycle system	/

Specification

Model			CC0440PWBI	CC0530PWBI	CC0740PWBI	CC0880PWBI	CC1100PWBI
Cooling capacity	Ton		125	150	205	250	303
	kW		440	528	721	879	1066
Power input COP	kW		74.7	87.9	121.0	146.5	174.7
	kW/kW		5.89	6.01	5.96	6.00	6.10
	kW/Ton		0.598	0.586	0.591	0.586	0.576
Starting current	A		2	2	2	2	2
Max. Running current	A		176	188	225	352	376
Max. Power input	kW		108	115	138	215	230
Safe protection			High/low pressure protection, safety protection, short of water relay protection, anti-freeze protection, motor overload, phase sequence and lack of phase protection				
Compressor	Type		Magnetic bearing compressor				
	Starting mode		Soft start				
Power supply			3~400,50Hz				
Refrigerant throttle type			Electronic expansion valves				
Capacity control			5%-100%				
Controller type			PLC control				
Refrigerant	Type		R134a				
	Charge	kg	200	210	250	400	420
Evaporator	Type		Flooded type				
	Chilled water inlet/ outlet temp.		12 °C/7 °C				
	Inlet/outlet pipe	DN	150	150	150	200	200
	Rated water flow	m ³ /h	76	91	124	151	183
	Water dirt coefficient	m ² °C/kW	0.0176				
	Standard pressure	MPa	1				
	Pass		4	4	2	2	2
	Water side resistance	kPa	83	80	44	75	77
Condenser	Type		Shell&tube heat exchanger				
	Cooling water inlet/ outlet temp.		30 °C/35 °C				
	Inlet/outlet pipe	DN	150	150	150	200	200
	Rated water flow	m ³ /h	89	106	145	176	213
	Water dirt coefficient	m ² °C/kW	0.044				
	Standard pressure	MPa	1				
	Pass		4	4	2	2	2
	Water side resistance	kPa	77	75	55	72	72
External dimension	Unit length	mm	2500	2500	2800	4400	4400
	Unit width	mm	1200	1200	1200	1200	1200
	Unit height	mm	2100	2100	2100	2100	2100
Weight	Net weight	Kg	2370	2480	2550	3910	4190
	Gross weight	Kg	2410	2520	2550	3960	4240
	Operation weight	Kg	2670	2830	2900	4410	4740

Note:

- Above parameters are based on the standard products;
- Above products standard pressure is 1.0Mpa - Contact with haier technology engineer, if you need the pressure higher than 1.0Mpa.
- Except above standard models, haier also can be customized products according to customer's requirements;
- Due to our policy of innovation some specifications maybe changed without notification;
- Model CC1330PWNI-CC2810PWNI is split type chiller, the installer need to combine the chiller on site;
- CC1330PWNI,CC1400PWNI,CC1580PWNI can be customized for U-shaped unit with 2 passes."

Water Cooled Oil Free Centrifugal Chiller

Model			CC1330PWBI	CC1400PWBI	CC1580PWBI	CC1760PWBI
Cooling capacity	Ton		378	400	450	500
	kW		1329	1407	1583	1759
Power input COP	kW		217.6	230.7	259.5	287.9
	kW/kW		6.11	6.10	6.10	6.11
	kW/Ton		0.576	0.577	0.577	0.576
Starting current	A		2	2	2	2
Max. running current	A		528	528	564	704
Max. power input	kW		323	323	345	431
Safe protection			High/low pressure protection, safety protection, short of water relay protection, anti-freed protection, motor overload, phase sequence and lack of phase protection			
Compressor	Type		Magnetic bearing compressor			
	Starting mode		Soft start			
Power supply			3-400,50Hz			
Refrigerant throttle type			Electronic expansion valves			
Capacity control			5%-100%			
Controller type			PLC control			
Refrigerant	Type		R134a			
	Charge	kg	600	630	630	800
Evaporator	Type		Flooded type			
	Chilled water inlet/ outlet temp.		12°C /7°C			
	Inlet/outlet pipe	DN	250	250	250	250
	Rated water flow	m ³ /h	229	242	272	303
	Water dirt coefficient	m ² °C/kW	0.0176			
	Standard pressure	MPa	1			
	Pass		1	1	1	2
	Water side resistance	kPa	36	33	35	75
Condenser	Type		Shell&tube heat exchanger			
	Cooling water inlet/ outlet temp.		30°C /35°C			
	Inlet/outlet pipe	DN	250	250	250	250
	Rated water flow	m ³ /h	266	282	317	352
	Water dirt coefficient	m ² °C/kW	0.044			
	Standard pressure	MPa	1			
	Pass		1	1	1	2
	Water side resistance	kPa	33	33	33	72
External dimension	Unit length	mm	6520	6520	6520	4800
	Unit width	mm	1200	1200	1200	2250
	Unit height	mm	2100	2100	2100	2250
Weight	Net weight	Kg	5130	5680	6260	8200
	Gross weight	Kg	5200	5750	6330	8280
	Operation weight	Kg	5880	6480	7060	9200

Note:

- Above parameters are based on the standard products;
- Above products standard pressure is 1.0Mpa - Contact with haier technology engineer, if you need the pressure higher than 1.0Mpa.
- Except above standard models, haier also can be customized products according to customer's requirements;
- Due to our policy of innovation some specifications maybe changed without notification;
- Model CC1330PWNI-CC2810PWNI is split type chiller, the installer need to combine the chiller on site;
- CC1330PWNI,CC1400PWNI,CC1580PWNI can be customized for U-shaped unit with 2 passes."

Specification

Model			CC1930PWBI	CC2110PWBI	CC2640PWBI	CC2810PWBI
Cooling capacity	Ton		550	600	750	800
	kW		1934	2110	2637	2814
Power input COP	kW		316.5	344.2	430.1	457.6
	kW/kW		6.11	6.13	6.13	6.15
	kW/Ton		0.576	0.574	0.573	0.572
Starting current	A		2	2	2	2
Max. running current	A		720	752	900	940
Max. power input	kW		441	460	551	575
Safe protection			High/low pressure protection, safety protection, short of water relay protection, anti-freed protection, motor overload, phase sequence and lack of phase protection			
Compressor	Type		Magnetic bearing compressor			
	Starting mode		Soft start			
Power supply			3-400,50Hz			
Refrigerant throttle type			Electronic expansion valves			
Capacity control			5%-100%			
Controller type			PLC control			
Refrigerant	Type		R134a			
	Charge	kg	820	840	1050	1100
Evaporator	Type		Flooded type			
	Chilled water inlet/ outlet temp.		12°C /7°C			
	Inlet/outlet pipe	DN	250	250	300	300
	Rated water flow	m ³ /h	333	363	454	484
	Water dirt coefficient	m ² °C/kW	0.0176			
	Standard pressure	MPa	1			
	Pass		2	2	2	2
	Water side resistance	kPa	75	73	99	99
Condenser	Type		Shell&tube heat exchanger			
	Cooling water inlet/ outlet temp.		30°C /35°C			
	Inlet/outlet pipe	DN	250	250	300	300
	Rated water flow	m ³ /h	387	422	528	563
	Water dirt coefficient	m ² °C/kW	0.044			
	Standard pressure	MPa	1			
	Pass		2	2	2	2
	Water side resistance	kPa	72	68	99	95
External dimension	Unit length	mm	4800	4800	6750	6750
	Unit width	mm	2250	2250	2250	2250
	Unit height	mm	2250	2250	2250	2250
Weight	Net weight	Kg	8300	8350	11150	11350
	Gross weight	Kg	8380	8430	11300	11500
	Operation weight	Kg	9400	9450	12350	12650

Note:

- Above parameters are based on the standard products;
- Above products standard pressure is 1.0Mpa - Contact with haier technology engineer, if you need the pressure higher than 1.0Mpa.
- Except above standard models, haier also can be customized products according to customer's requirements;
- Due to our policy of innovation some specifications maybe changed without notification;
- Model CC1330PWNI-CC2810PWNI is split type chiller, the installer need to combine the chiller on site;
- CC1330PWNI,CC1400PWNI,CC1580PWNI can be customized for U-shaped unit with 2 passes."

Water Cooled Oil Free Centrifugal Chiller

Model			CC3170PWBI	CC3520PWBI	CC3870PWBI	CC4220PWBI
Cooling capacity	Ton		900	1000	1100	1200
	kW		3165	3517	3869	4220
Power input COP	kW		518.0	571.9	631.1	689.5
	kW/kW		6.11	6.15	6.13	6.12
	kW/Ton		0.576	0.572	0.574	0.575
Starting current	A		2	2	2	2
Max. running current	A		1080	1125	1260	1440
Max. power input	kW		661	689	771	881
Safe protection			High/low pressure protection, safety protection, short of water relay protection, anti-freed protection, motor overload, phase sequence and lack of phase protection			
Compressor	Type		Magnetic bearing compressor			
	Starting mode		Soft start			
Power supply			3-400,50Hz			
Refrigerant throttle type			Electronic expansion valves			
Capacity control			5%-100%			
Controller type			PLC control			
Refrigerant	Type		R134a			
	Charge	kg	1200	1250	1400	1600
Evaporator	Type		Flooded type			
	Chilled water inlet/ outlet temp.		12°C /7°C			
	Inlet/outlet pipe	DN	350	350	350	350
	Rated water flow	m ³ /h	544	605	665	726
	Water dirt coefficient	m ² °C/kW	0.0176			
	Standard pressure	MPa	1			
	Pass		2	2	2	2
	Water side resistance	kPa	55	58	85	82
Condenser	Type		Shell&tube heat exchanger			
	Cooling water inlet/ outlet temp.		30°C /35°C			
	Inlet/outlet pipe	DN	350	350	350	350
	Rated water flow	m ³ /h	633	703	774	844
	Water dirt coefficient	m ² °C/kW	0.044			
	Standard pressure	MPa	1			
	Pass		2	2	2	2
	Water side resistance	kPa	58	65	96	87
External dimension	Unit length	mm	4300	5100	5100	5100
	Unit width	mm	3200	3200	3200	3200
	Unit height	mm	2550	2550	2550	2550
Weight	Net weight	Kg	11950	13500	14550	15350
	Gross weight	Kg	12100	13650	14700	15500
	Operation weight	Kg	15450	17000	18050	19350

Note:

- Above parameters are based on the standard products;
- Above products standard pressure is 1.0Mpa - Contact with haier technology engineer, if you need the pressure higher than 1.0Mpa.
- Except above standard models, haier also can be customized products according to customer's requirements;
- Due to our policy of innovation some specifications maybe changed without notification;
- Model CC1330PWNI-CC2810PWNI is split type chiller, the installer need to combine the chiller on site;
- CC1330PWNI,CC1400PWNI,CC1580PWNI can be customized for U-shaped unit with 2 passes."

Specification

Model			CC5280PWBI	CC6330PWBI
Cooling capacity	Ton		1500	1800
	kW		5275	6330.6
Power input COP	kW		858	1029.4
	kW/kW		6.15	6.15
	kW/Ton		0.572	0.572
Starting current	A		2	2
Max. running current	A		1800	2025
Max. power input	kW		1102	1239
Safe protection			High/low pressure protection, safety protection, short of water relay protection, anti-freed protection, motor overload, phase sequence and lack of phase protection	
Compressor	Type		Magnetic bearing compressor	
	Starting mode		Soft start	
Power supply			3-400,50Hz	
Refrigerant throttle type			Electronic expansion valves	
Capacity control			5%-100%	
Controller type			PLC control	
Refrigerant	Type		R134a	
	Charge	kg	1900	2400
Evaporator	Type		Flooded type	
	Chilled water inlet/ outlet temp.		12°C /7°C	
	Inlet/outlet pipe	DN	400	450
	Rated water flow	m ³ /h	907	1089
	Water dirt coefficient	m ² °C/kW	0.0176	
	Standard pressure	MPa	1	
	Pass		2	2
	Water side resistance	kPa	95	93
Condenser	Type		Shell&tube heat exchanger	
	Cooling water inlet/ outlet temp.		30°C /35°C	
	Inlet/outlet pipe	DN	400	450
	Rated water flow	m ³ /h	1055	1266
	Water dirt coefficient	m ² °C/kW	0.044	
	Standard pressure	MPa	1	
	Pass		2	2
	Water side resistance	kPa	96	96
External dimension	Unit length	mm	6600	7700
	Unit width	mm	3200	3500
	Unit height	mm	2550	2500
Weight	Net weight	Kg	19110	25310
	Gross weight	Kg	19260	25460
	Operation weight	Kg	22610	29810

Note:

- Above parameters are based on the standard products;
- Above products standard pressure is 1.0Mpa - Contact with haier technology engineer, if you need the pressure higher than 1.0Mpa.
- Except above standard models, haier also can be customized products according to customer's requirements;
- Due to our policy of innovation some specifications maybe changed without notification;
- Model CC1330PWNI-CC2810PWNI is split type chiller, the installer need to combine the chiller on site;
- CC1330PWNI,CC1400PWNI,CC1580PWNI can be customized for U-shaped unit with 2 passes."

Water Cooled Oil Free Centrifugal Chiller

Unit Dimension Diagram

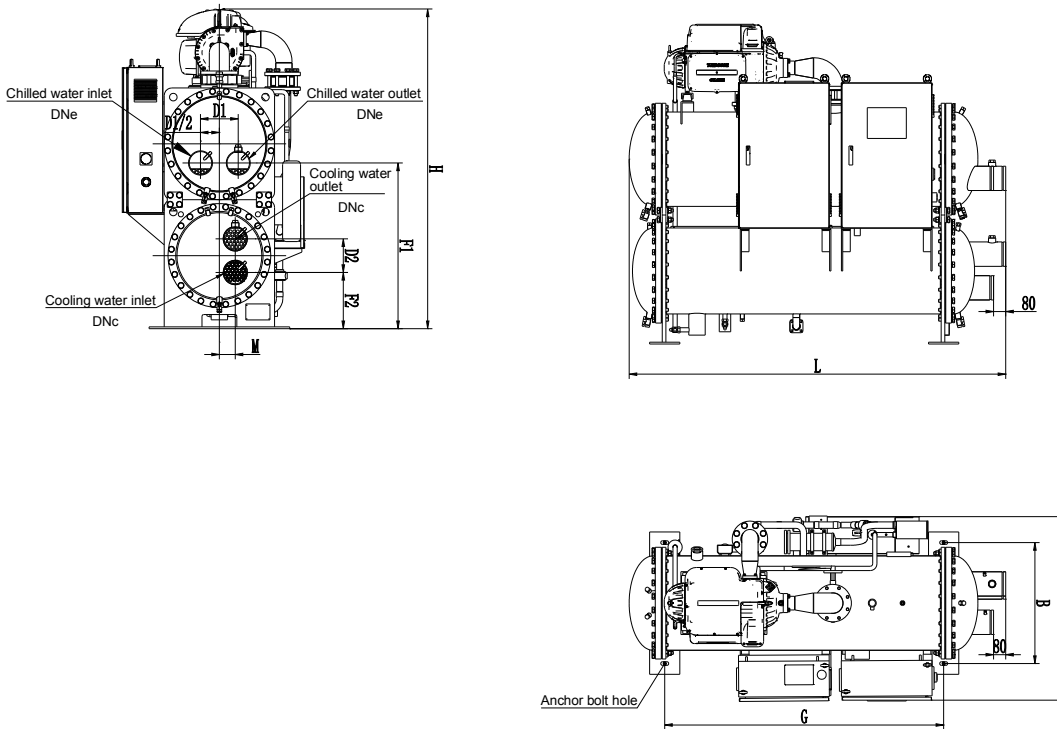

CODE MODEL	External dimensions mm			Installation dimensions mm		Nozzle dimensions mm						
	L	W	H	B	G	D1	D2	F1	F2	M	DNe	DNc
CC0440PWNI	2500	1200	2100	790	1846	250	220	1082	367	105	DN150	DN150
CC0530PWNI	2500	1200	2100	790	1846	250	220	1082	367	105	DN150	DN150

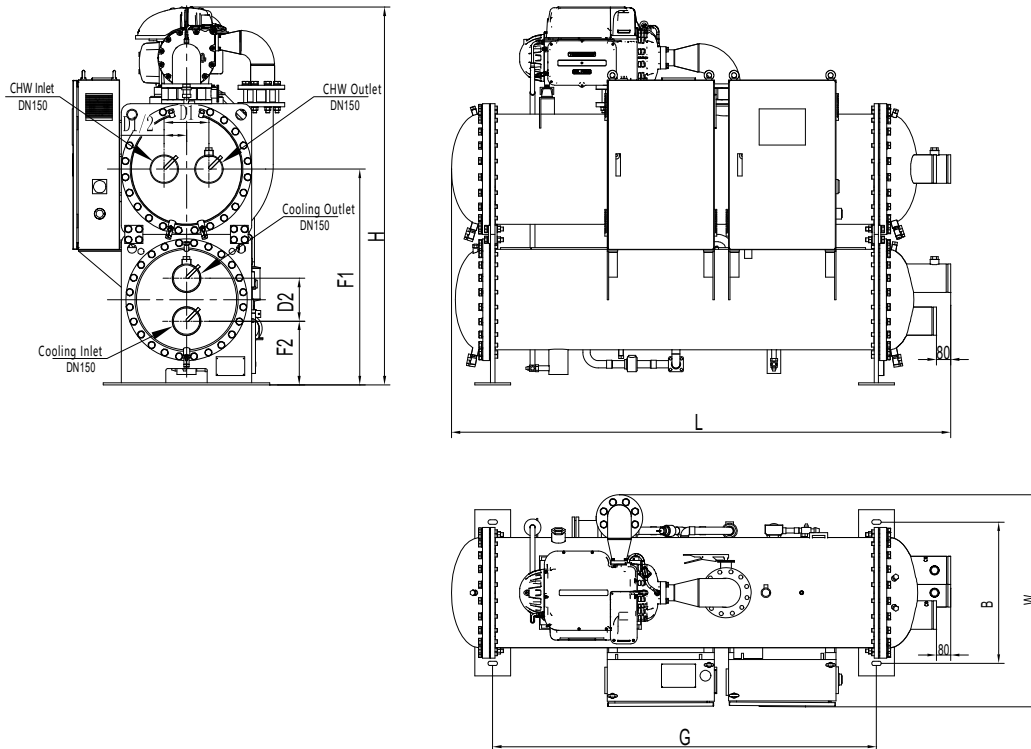

Code Model	External Dimensions mm			Installation Dimensions mm		Nozzle Dimensions mm					
	L	W	H	B	G	D1	D2	F1	F2	DNe	DNc
CC0740PWNI	2800	1200	2100	790	2146	250	240	1207	375	DN150	DN150

Unit Dimension Diagram

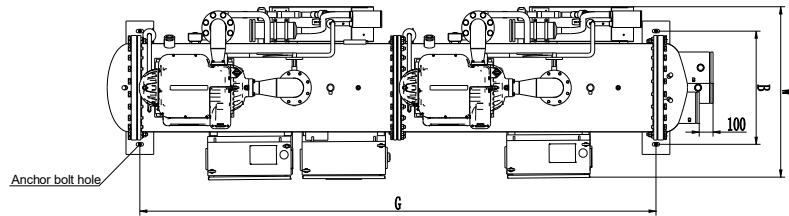
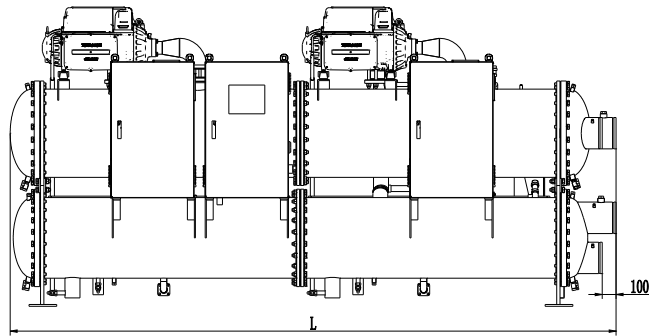
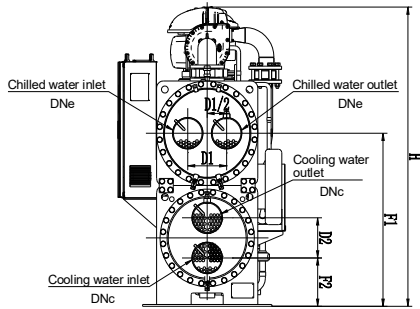

CODE MODEL	External dimensions mm			Installation dimensions mm		Nozzle dimensions mm					
	L	W	H	B	G	D1	D2	F1	F2	DNe	DNc
CC0880PWNI	4400	1200	2100	790	3719	280	280	1207	337	DN200	DN200
CC1100PWNI	4400	1200	2100	790	3719	280	280	1207	337	DN200	DN200

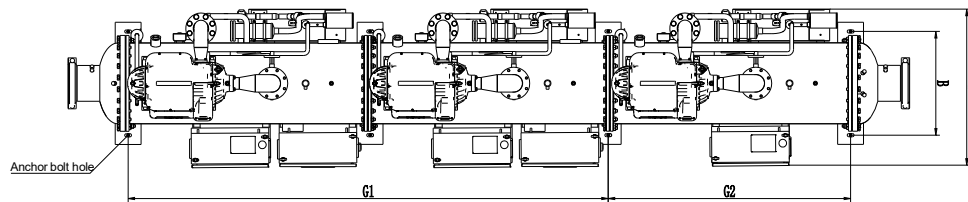
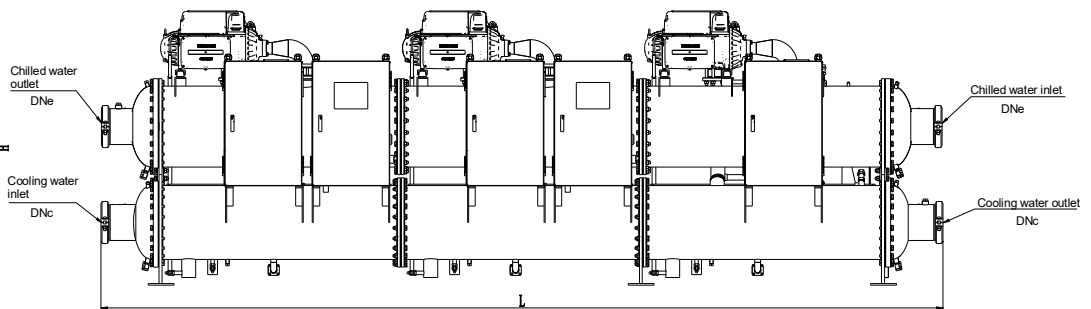
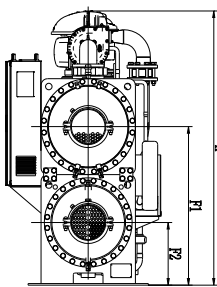

CODE MODEL	External dimensions mm			Installation dimensions mm			Nozzle dimensions mm				
	L	W	H	B	G1	G2	F1	F2	M	DNe	DNc
CC1330PWNI	6520	1200	2100	790	3719	1846	1207	477	940	DN250	DN250
CC1400PWNI	6520	1200	2100	790	3719	1846	1207	477	940	DN250	DN250
CC1580PWNI	6520	1200	2100	790	3719	1846	1207	477	940	DN250	DN250

Water Cooled Oil Free Centrifugal Chiller

Unit Dimension Diagram

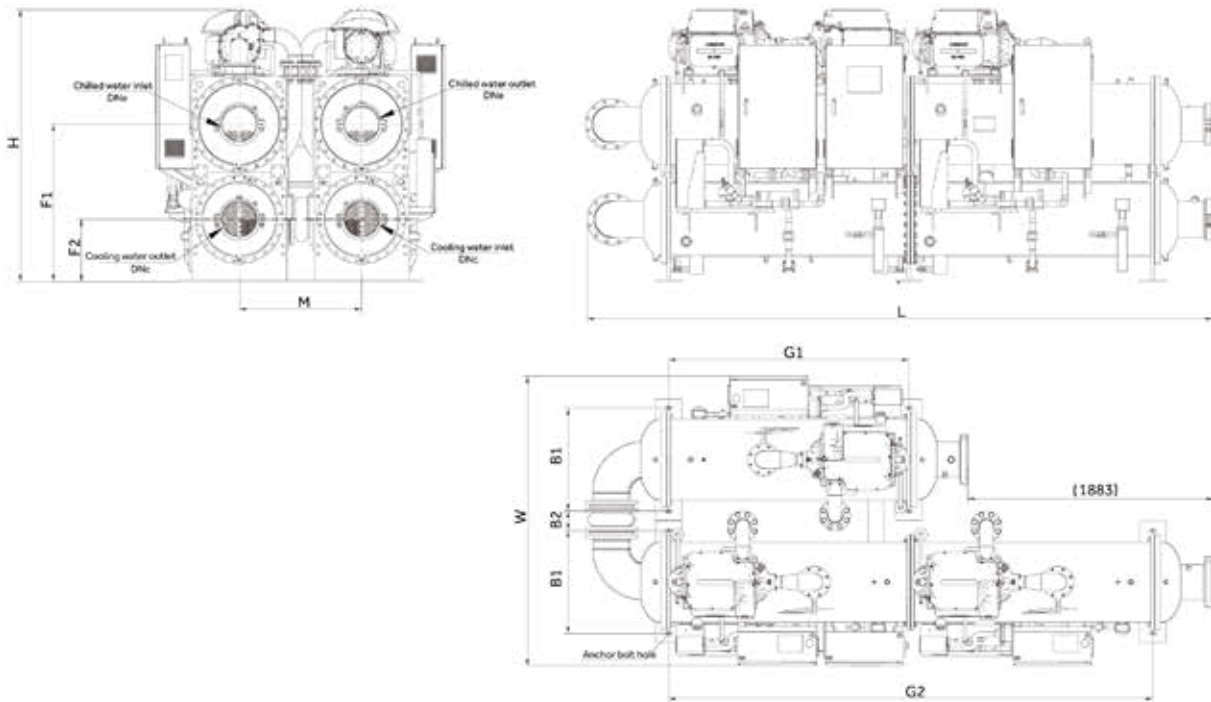

MODEL	CODE	External dimensions mm			Installation dimensions mm				Nozzle dimensions mm				
		L	W	H	B1	B2	G1	G2	F1	F2	M	DNc	DNc
CC1330PWNI		4800	2250	2250	790	150	1846	3719	1307	477	940	DN250	DN250
CC1400PWNI		4800	2250	2250	790	150	1846	3719	1307	477	940	DN250	DN250
CC1580PWNI		4800	2250	2250	790	150	1846	3719	1307	477	940	DN250	DN250

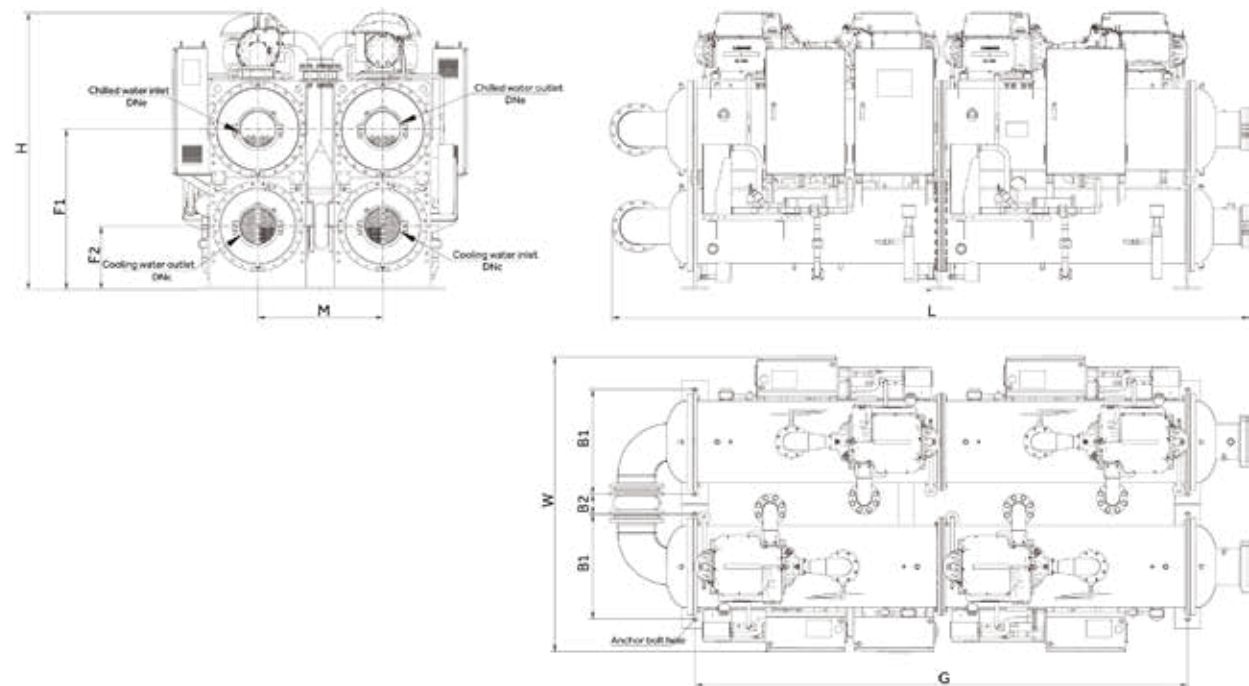

MODEL	CODE	External dimensions mm			Installation dimensions mm				Nozzle dimensions mm			
		L	W	H	B1	B2	G	F1	F2	M	DNc	DNc
CC1760PWNI		4800	2250	2250	790	150	3719	1307	477	940	DN250	DN250
CC1930PWNI		4800	2250	2250	790	150	3719	1307	477	940	DN250	DN250
CC2110PWNI		4800	2250	2250	790	150	3719	1307	477	940	DN250	DN250

Unit Dimension Diagram

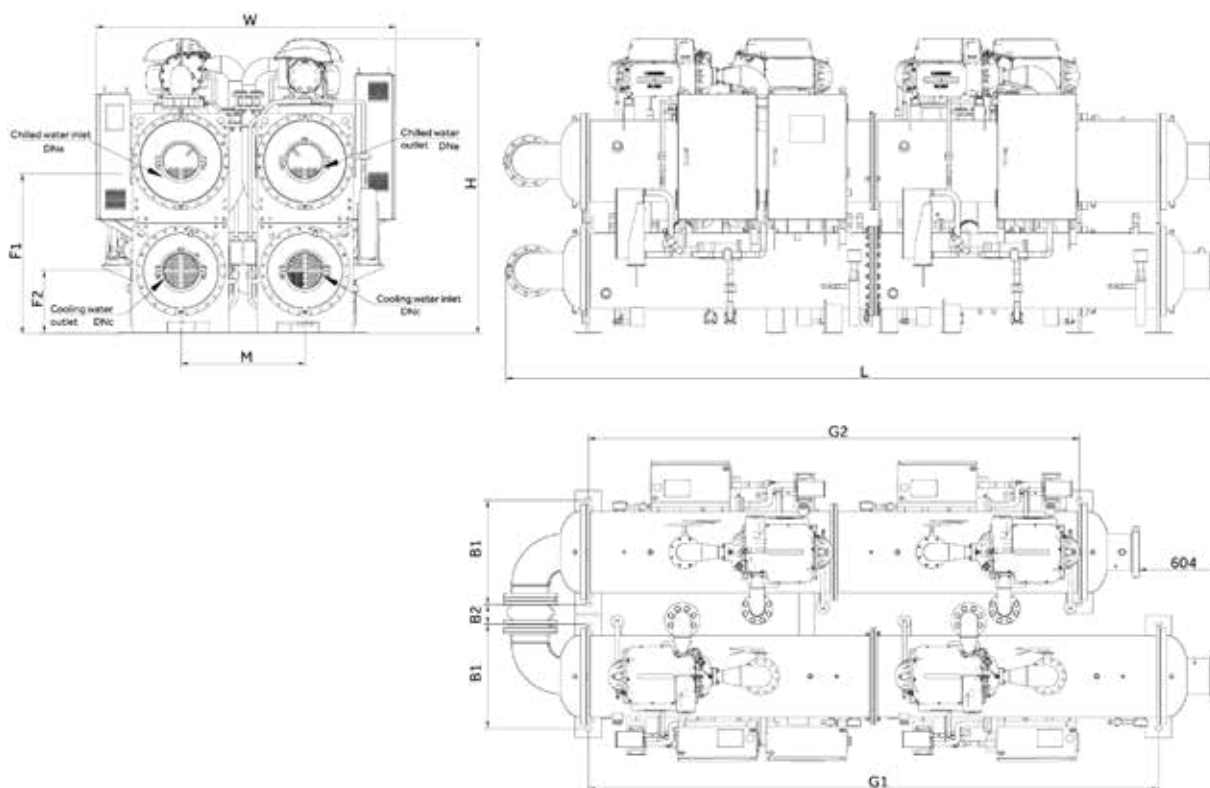

MODEL	CODE	External dimensions mm			Installation dimensions mm				Nozzle dimensions mm				
		L	W	H	B1	B2	G1	G2	F1	F2	M	DN _e	DN _c
CC2460PWNI		5440	2280	2250	790	150	4319	3719	1307	477	940	DN250	DN250

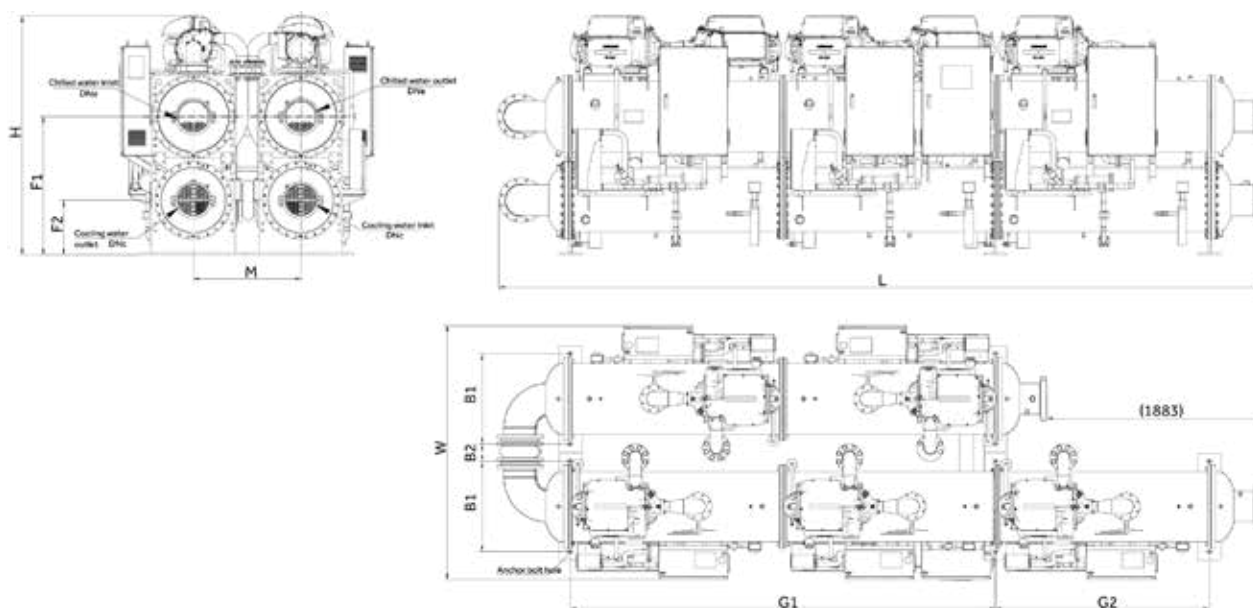

MODEL	CODE	External dimensions mm			Installation dimensions mm				Nozzle dimensions mm				
		L	W	H	B1	B2	G1	G2	F1	F2	M	DN _e	DN _c
CC2640PWNI		6750	2250	2250	790	150	3719	1846	1307	477	940	DN300	DN300
CC2810PWNI		6750	2250	2250	790	150	3719	1846	1307	477	940	DN300	DN300

Water Cooled Oil Free Centrifugal Chiller

Unit Dimension Diagram

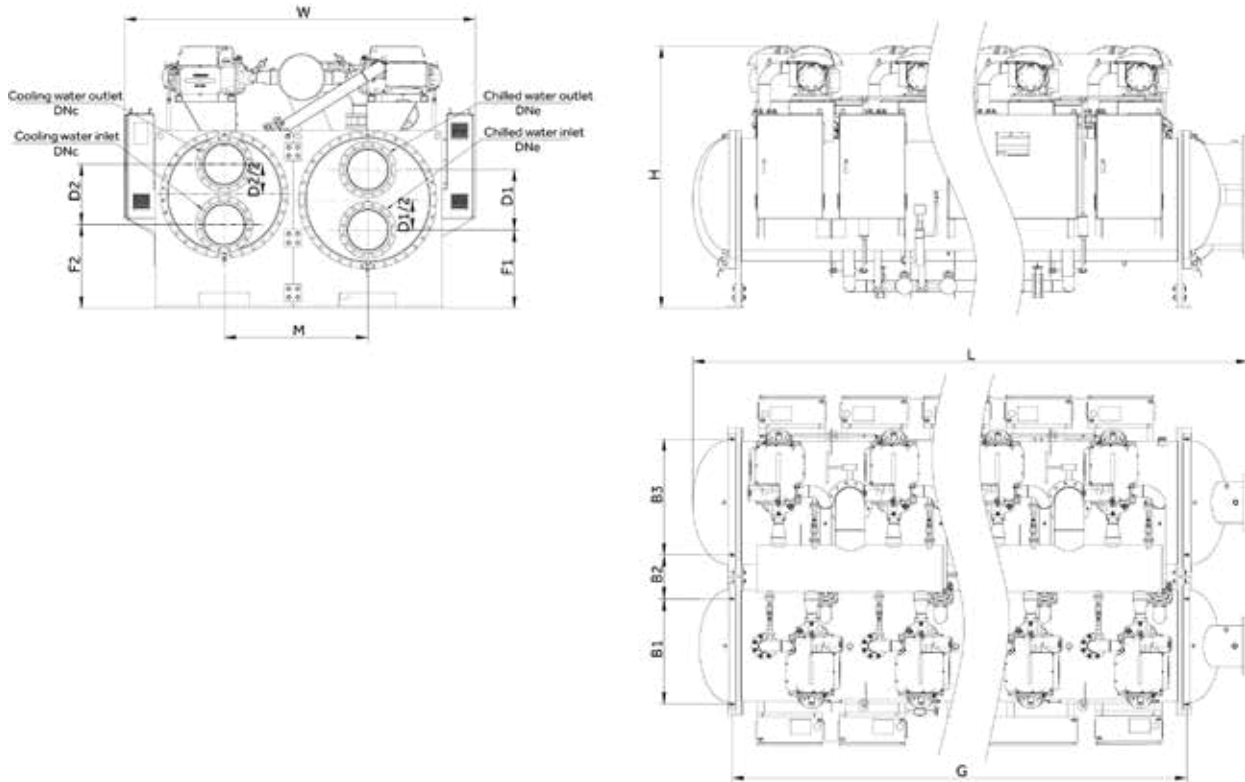

CODE MODEL	External dimensions mm			Installation dimensions mm						Nozzle dimensions mm						
	L	W	H	B1	B2	B3	G1	G2	G3	D1	D2	F1	F2	M	DN _e	DN _c
CC3170PWNI	4300	3200	2550	960	400	1060	3348			550	550	715	765	1310	DN350	DN350
CC3520PWNI	4300	3200	2550	960	400	1060	3348			550	550	715	765	1310	DN350	DN350
CC3870PWNI	5100	3200	2550	960	400	1060	4148			550	550	715	765	1310	DN350	DN350
CC4220PWNI	5100	3200	2550	960	400	1060	4148			550	550	715	765	1310	DN350	DN350
CC5280PWNI	6600	3800	2700	1160	400	1160	4148			550	550	715	765	1310	DN400	DN400
CC6330PWNI	6600	3800	2700	1160	400	1160		3348	2170	620	620	730	730	1460	DN450	DN450
CC7030PWNI	6600	3800	2700	1160	400	1160		3348	2170	620	620	730	730	1460	DN450	DN450

Unit Dimension Diagram

mm

Model	A	B	C	D	E
CC0440-CC0530PWNI	500	2000	1500	1500	1500
CC0740PWNI	500	2300	1500	1500	1500
CC0880-CC2110PWNI	500	2000	1500	1500	2000
CC2460PWNI	500	2300	1500	1500	2300
CC2640-CC2810PWNI	500	2000	1500	1500	2000
CC3170PWNI	1000	3500	1500	1500	2000
CC3520-CC4220PWNI	1000	4200	1500	1500	2000
CC5280-CC7030PWNI	1000	3500	1500	1500	2300

Note: Above data is minimum dimension

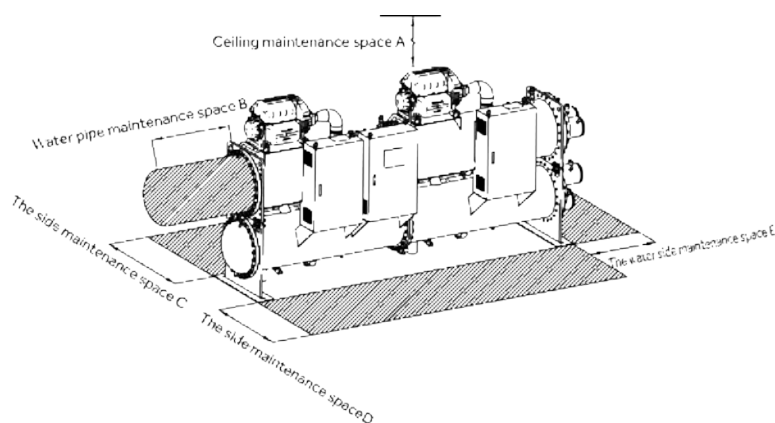

Haier
Air Conditioning



**R410A
MODULAR
CHILLER**



Air Cooled Modular Heat Pump Chiller

Air cooled/Heat pump
Cooling capacity range from 30kW up to 2080kW



R410a



Features



New Appearance

New Y-shape design, more fashionable

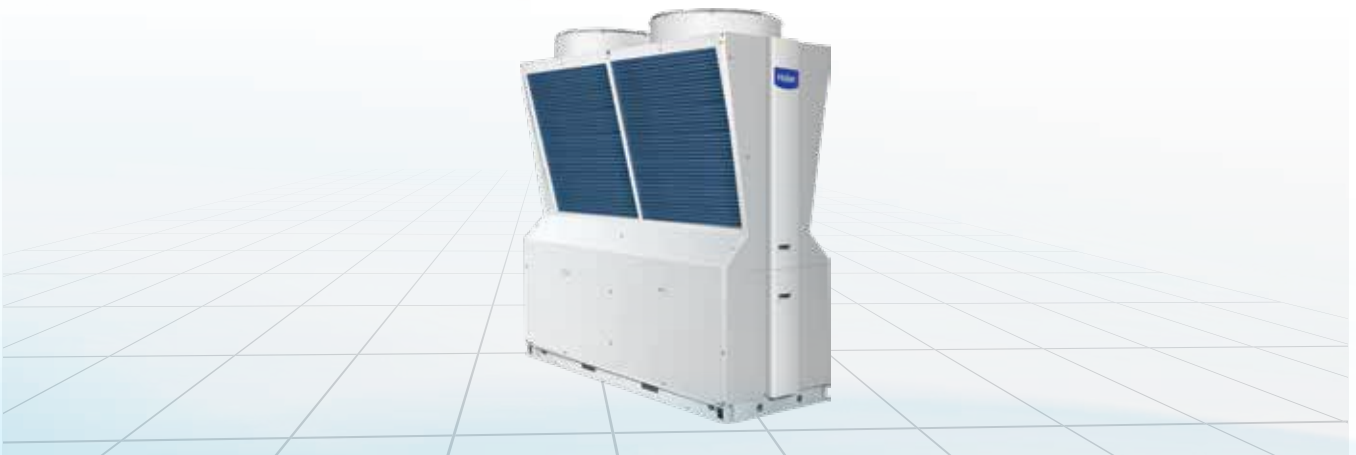

Specification

Model			CA0035EAND	CA0070EAND	CA0100EAND	CA0130EAND
Cooling	Cooling capacity	kW	30	65	98	130
	Power input	kW	9.4	19.2	28.9	38.4
	Running current	A	15.8	34.6	53.2	75.4
Heating	Heating capacity	kW	33	70	103	135
	Power input	kW	9.6	19.1	28.7	38.2
	Running current	A	16.2	34.4	52.8	75
COPR		kW/kW	3.19	3.39	3.39	3.39
COPH		kW/kW	3.44	3.66	3.59	3.53
Max.Power input		kW	16.3	28	45.6	56
Max. running current		A	27.5	55	82.5	110
Power supply			3~/380V/50Hz			
Refrigerant throttle type			Electronic expansion valve			
Capacity control			100%	50%,100%	33%,67%, 100%	25%,50%, 75%,100%
Safety & functional protections			High/low Pressure Protection,Water flow delay Protection, Freeze Protection,Overload & Overheat Protection, Phase Loss, Phase Sequence Protection			
Compressor	Type		Scroll compressor			
	Quantity		1	2	3	4
	Input power	KW	9	18	27	36
Refrigerant	Type		R410A			
	Charge	kg	5.5	6*2	5.8*3	5.8*4
Air side heat exchanger	Type		(Slit fin & efficient inner grooved copper tube) Inner grooved copper pipe & hydrophilic aluminum fin coil			
	Fan power	KW	0.7	1.5	2.3	3
	Fan type		Axial flow fan			
	Fan quantity		1	2	3	4
Water side heat exchanger	Type		Plate heat exchanger	Shell & Tube heat exchanger		
	Rated water flow	m ³ /h	5.6	12	17.7	24
	Inlet/outlet pipe		DN65	R 2''' (external screw thread)		
	Water dirt coefficient	m ² °C/KW	0.018			
	Standard pressure	Mpa	1.0	1.0	1.0	1.0
	Water resistance	kPa	40	45	50	60
Sound level		dB(A)	60	65	67	68
External dimension	Unit length	mm	918	2060	2060	2060
	Unit width	mm	1038	780	1603	1603
	Unit height	mm	1810	2170	2170	2170
Package dimension	Unit length	mm	1075	2200	2200	2200
	Unit width	mm	940	830	1650	1650
	Unit height	mm	1950	2280	2280	2280
Weight	Unit weight	kg	270	630	960	1090
	Gross weight	kg	290	645	990	1125
	Operation weight	kg	280	670	1010	1245

Note:

- Specifications are based on the following condition:
 - Cooling: chilled water inlet/outlet: 12°C /7°C , and outdoor ambient temp. 35°C DB;
 - Heating: warm water inlet/outlet: 40°C /45°C , and outdoor ambient temp. 7°C DB/6°C WB;
 - Water side fouling factor: 0.086m²•°C /kW
 - 1m away in open field (sound pressure)
- Due to our policy of innovation, some specifications may be changed without notification.

Air Cooled R410a Modular Heat Pump Chiller

Performance Table



R410a:CA0035EAND

- Cooling capacity table

Water outlet temp.(°C)	Ambient temperature				
	25	30	35	40	45
5	1.03	0.97	0.94	0.90	0.85
7	1.07	1.03	1.00	0.95	0.88
9	1.10	1.06	1.03	0.98	0.91
11	1.12	1.10	1.08	1.02	0.97
13	1.19	1.20	1.15	1.10	1.05
15	1.31	1.31	1.26	1.20	1.15

- Heating capacity table

Water outlet temp.(°C)	Ambient temperature							
	15	10	7	5	0	-5	-10	-15
30	1.23	1.15	1.11	1.06	0.87	0.80	0.71	0.6208
35	1.13	1.10	1.08	0.83	0.74	0.68	0.58	0.57
40	1.13	1.09	1.05	0.83	0.74	0.66	0.57	0.55
45	1.13	1.09	1.00	0.83	0.74	0.64	0.57	0.53
50	1.13	1.07	0.92	0.81	0.74	0.64	0.56	0.51
55	1.12	1.06	0.92	0.81	0.72	0.62	-	-

Note: 1. Capacity=Nominal capacity*correction ratio;
2. Correction ratio is the average data, please check service manual for details.



R410a:CA0070EAND/CA0100EAND/CA0130EAND

- Cooling capacity table

Water outlet temp.(°C)	Ambient temperature				
	25	30	35	40	45
5	1.07	1.00	0.94	0.94	0.81
7	1.14	1.07	1.00	0.96	0.86
9	1.20	1.13	1.06	0.98	0.91
11	1.27	1.19	1.12	1.04	0.96
13	1.34	1.26	1.17	1.09	1.01
15	1.41	1.32	1.23	1.14	1.06

- Heating capacity table

Water outlet temp.(°C)	Ambient temperature							
	15	10	7	5	0	-5	-10	-15
30	1.26	1.16	1.12	1.07	0.88	0.82	0.72	0.69
35	1.24	1.15	1.11	1.06	0.88	0.81	0.71	0.69
40	1.22	1.14	1.10	1.05	0.87	0.80	0.71	0.67
45	1.19	1.12	1.00	0.98	0.85	0.79	0.70	0.66
50	1.19	1.11	0.98	0.97	0.84	0.78	0.67	0.65
55	1.14	1.07	0.97	0.94	0.83	0.77	-	-

Note: 1. Capacity=Nominal capacity*correction ratio;
2. Correction ratio is the average data, please check service manual for details.

Chiller Water System And Control Wiring Diagram

 Water pipe and control wiring connection diagram for multi-modular chiller

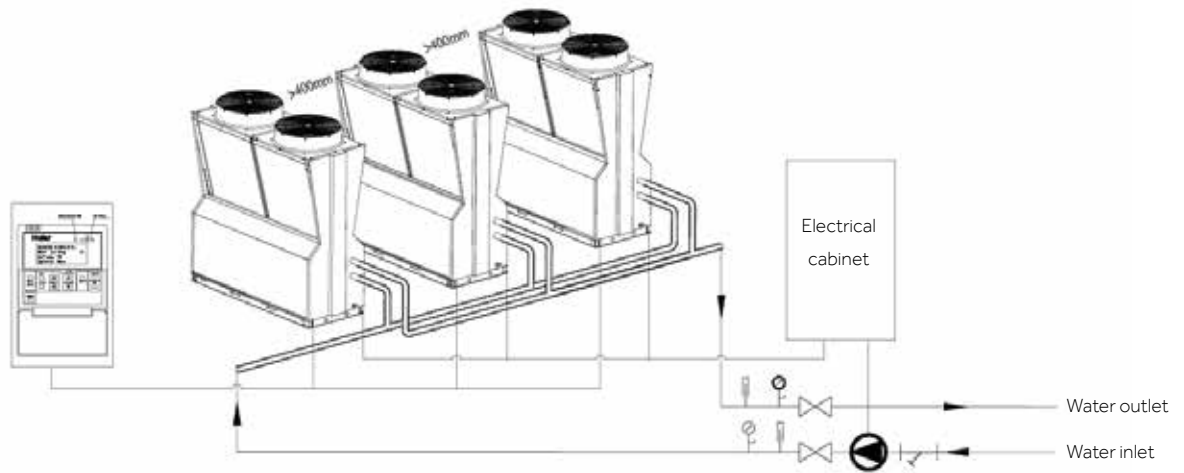

Control Wiring Diagram

 For example the model CA0070AAND

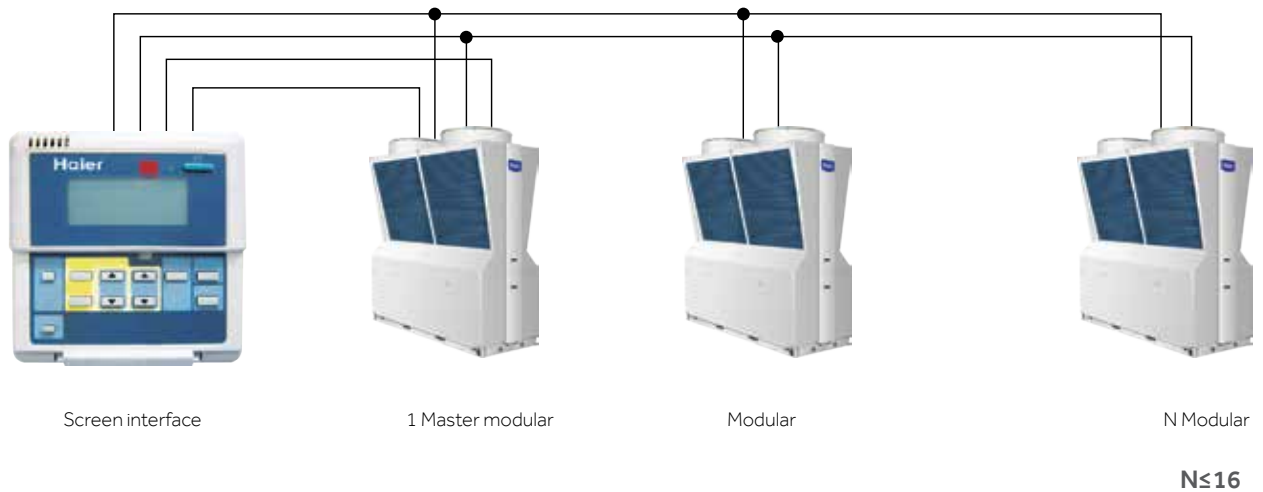

Air Cooled R410a Modular Heat Pump Chiller

Features

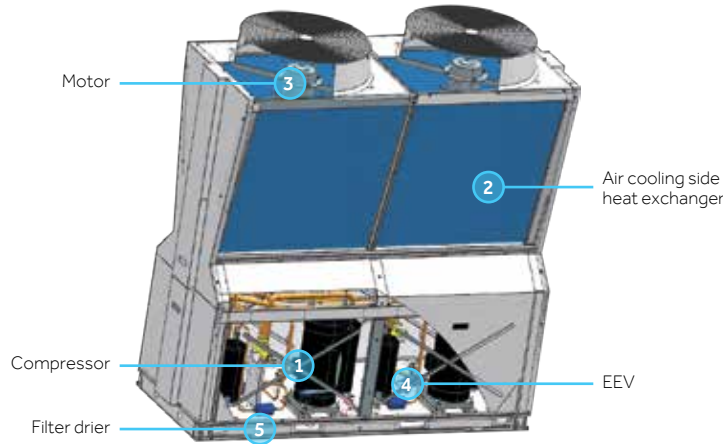

1 Compressor



Best scroll compressor, low sound power level, high EER.

2 Air cooling side heat exchanger



Haier modular chiller enlarge the heat exchanging area with 5%, bigger than normal modular chiller, increase EER.

3 Motor



Low sound power level axial fan, together with the high efficient motor, making higher efficiency and lower sound power level.

High efficient parts and unique design ensure the chiller high efficiency EER up to 3.39(R410a Series).

Easy Installation

Compact design, reduce footprint

New Y-shape design, small floor area, only 1.56m², 28% footprint reduction.

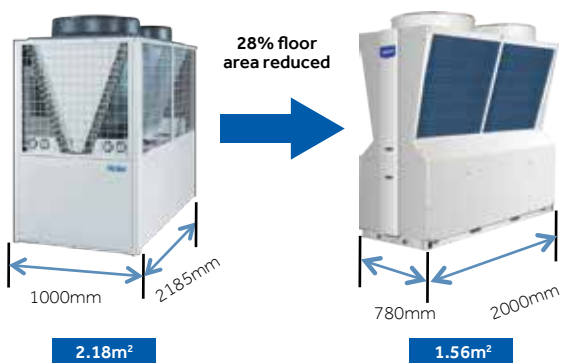

Standard flow switch

Standard flow switch in the product, installer no need to purchase a flow switch.



Wide Application

Wide temperature operation range

- -15°C in heating, 50°C in cooling.

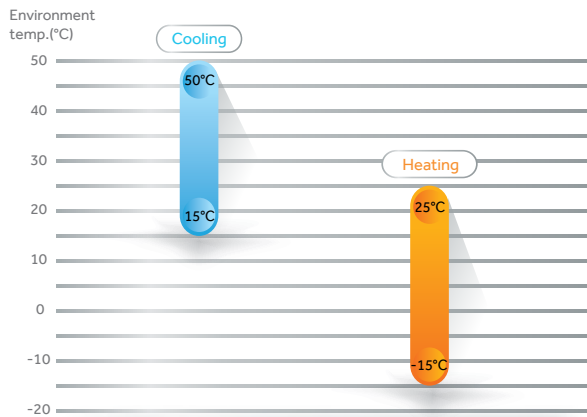

- Water outlet temp up to 55°C

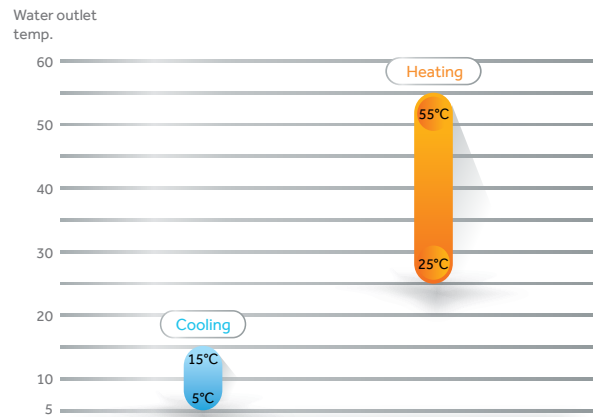

High Reliability

Shell & tube heat exchanger

The new modular chiller adopts shell & tube heat exchanger(65/100/130kW) avoid dirty fouling, higher efficiency and reliability.



Filter drier

Filter drier,absorb moisture in the system, and filter the refrigerant from impurities.



Pressure sensor control

Through the pressure sensor real-time monitoring, can be achieved quickly, accurately, ensure the unit operates most efficient and stable.

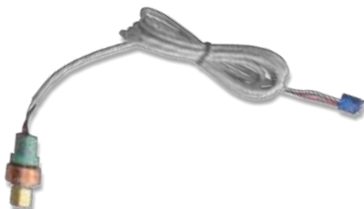

Three phase fan motor

Three phase fan motor: low starting current, high speed and more stable, when compared with single phase.



Air Cooled R410a Modular Heat Pump Chiller

High Reliability

Backup operation function

Sixteen modules can be connected in one system . If one module malfunction another module will start automatically according to the water temperature.

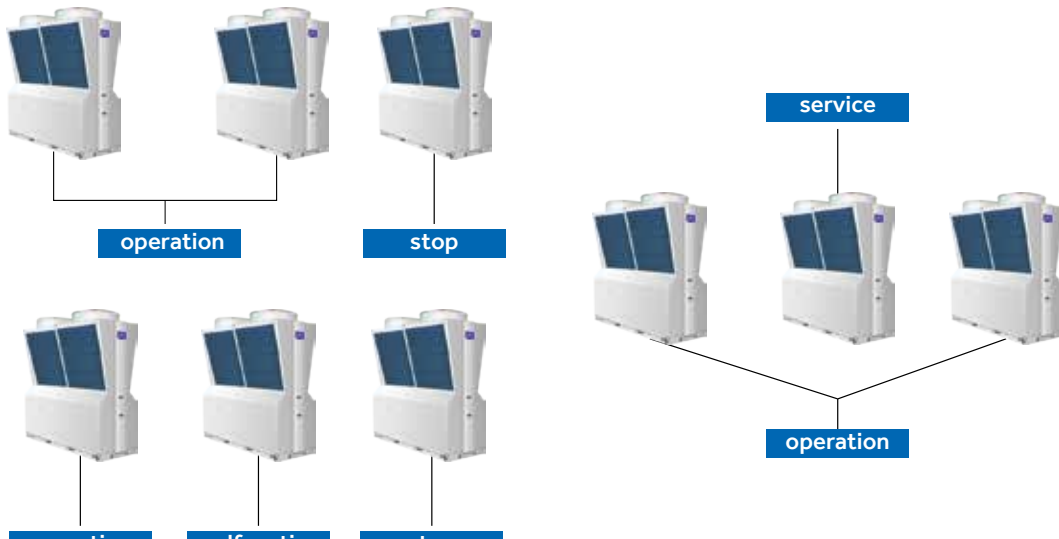

Safety and protection

Phase reverse protection, high and low pressure protection, freeze protection, overheat protection, overload protection, etc.



Comfort





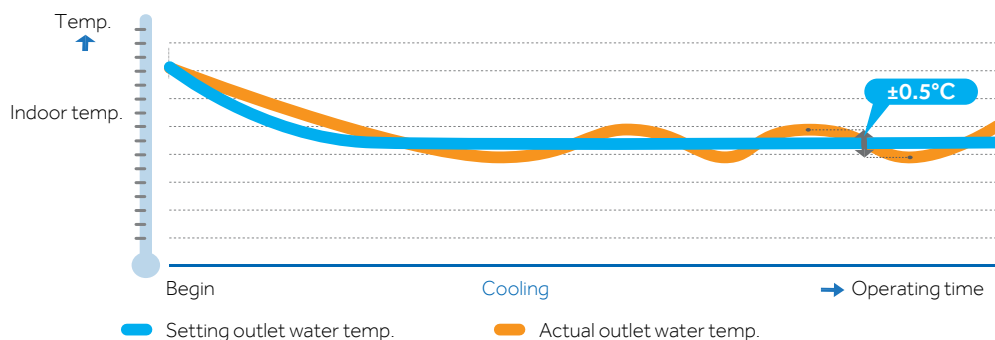



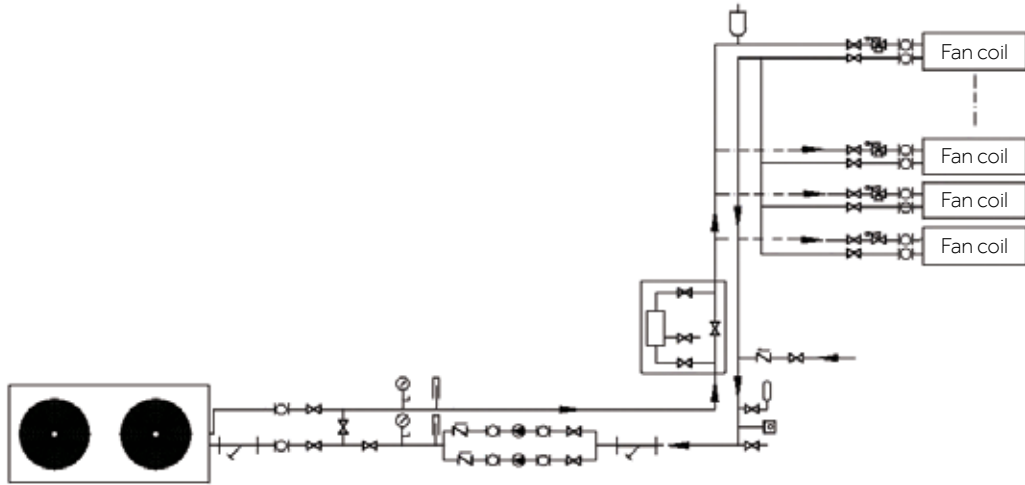



Accurately control water temperature

EEV adopts PID control, accurate control refrigerant distribution, outlet water temp. $\pm 5\%$ of the set temperature .



Water System Installation Sketch



Model	Description	Model	Description
	Check valve		Water pump
	Automatic exhaust valve		flexible connection
	Water filter		Expansion tank
	Stop valve		Electronic water processor
	Thermometer		3-way valve
	Pressure gauge		2-way valve

Air Cooled R410a Modular Heat Pump Chiller

Unit Dimension Diagram

R410a Y-shape air-cooled modular chiller dimension

CA0035EAND Model

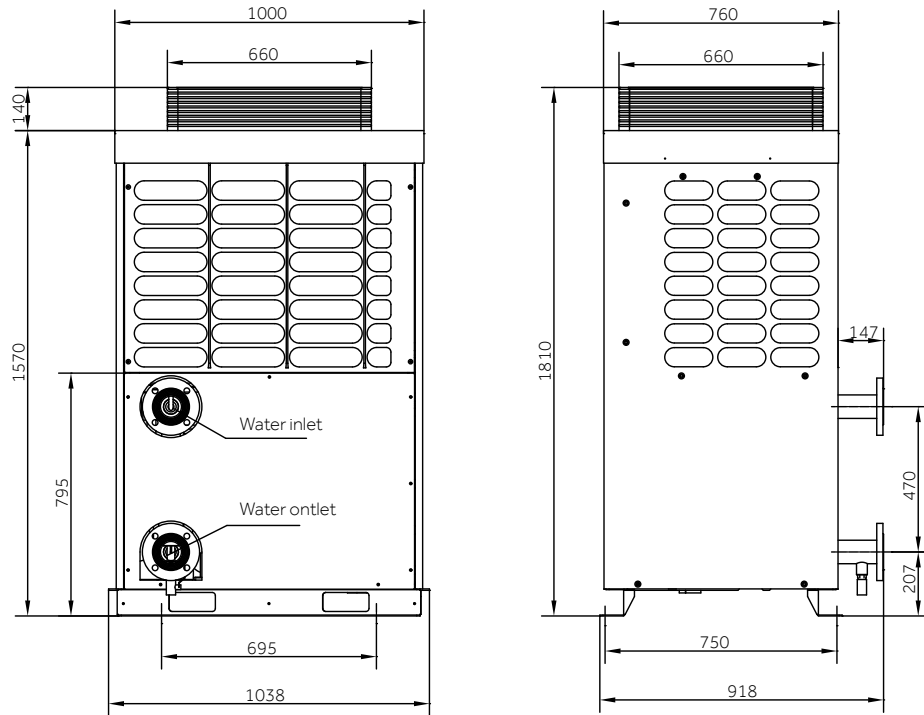

CA0070EAND Model

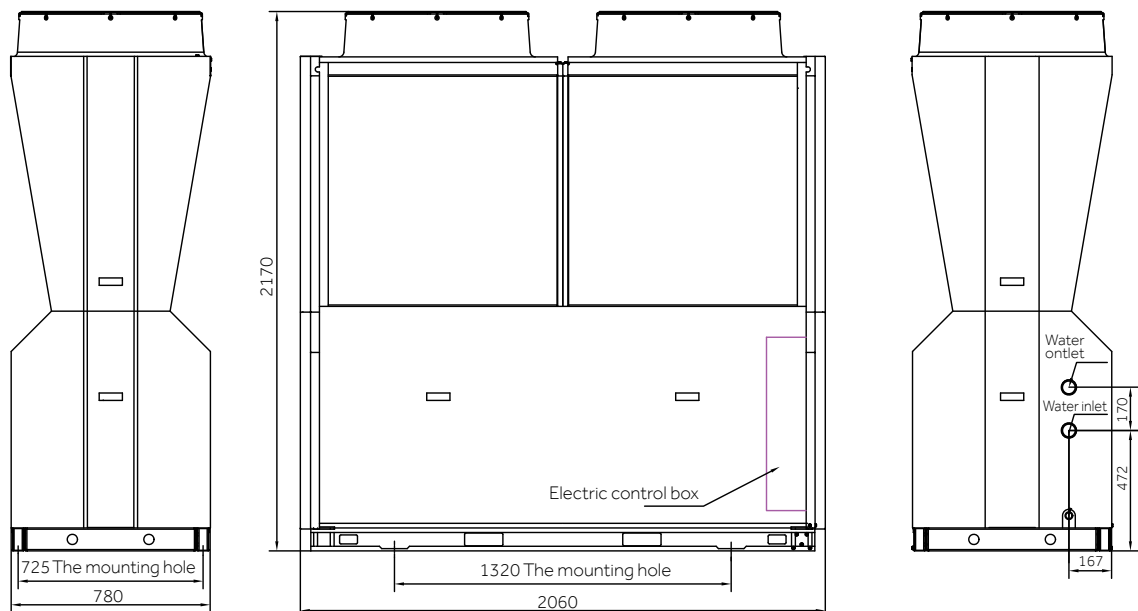

Unit Dimension Diagram

R410a Y-shape air-cooled modular chiller dimension

CA0100EAND/CA0130EAND Model

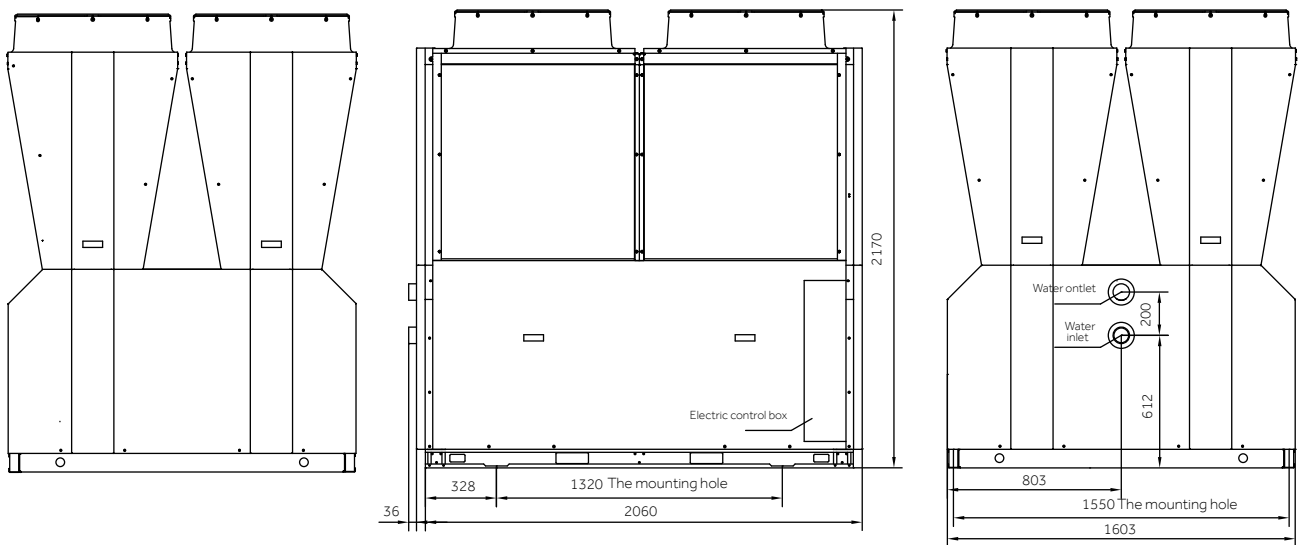

The Unit Installation & Maintenance Space

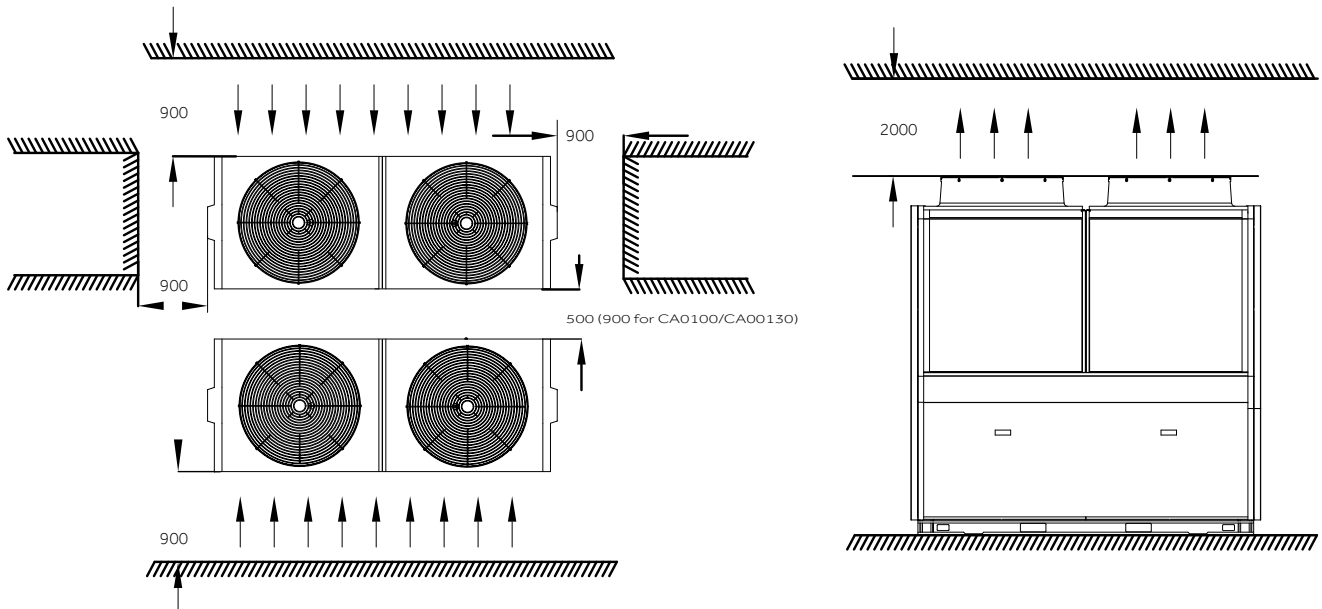



For Haier Appliances

Australia 1300 729 948 | haier.com.au

New Zealand 0800 424 372 | haier.co.nz

Important notice of Disclosure: Copyright © Fisher & Paykel Appliances 2018. All rights reserved.

The product dimensions and specifications in this brochure apply to the specific products and models described at the date of issue. Under our policy of continuous product improvement, these dimensions and specifications may change at any time. You should therefore check with your dealer or Haier's Customer Care Centre to ensure this flyer correctly describes the products currently available.

Fisher & Paykel Australia Pty Ltd, Level 1, 1 Eden Park Drive, Macquarie Park, NSW 2113.
Phone Customer Care: 1300 729 948 Email: customer.care@haier.com.au

Fisher & Paykel Appliances Ltd, 78 Springs Road, East Tamaki, Auckland 2013.
Phone Customer Care: 0800 424 372. Email: customer.care@haier.co.nz

Version 201904

Haier
Air Conditioning